

Application FA03

Add or Subtract Flow Computer

with 2 Input Channels for Energy Applications

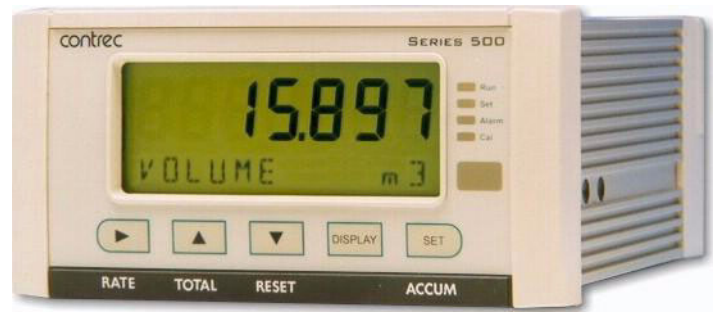

Features

- Programmable for either frequency or analog flow inputs
- Tailored for energy units of measure
- Freely assignable alarms for high or low levels
- Allows for non-linear correction
- Selection of second language and user tags
- RTC logging with over 1000 entries
- Infra-red communications port on front panel
- Pulse width and scaling of pulse output
- 4-20mA retransmission
- Selectable protocols on serial ports including Modbus RTU and Printer output
- Front panel adjustment of 8-24V DC output voltage
- Backlit display
- LCD backup



Overview

The 515 FA03 application pack is an add or subtract flow computer that is tailored specifically for energy measurement. It can perform either addition or subtraction on two frequency inputs or on two analog inputs.

The flow computer is suitable for collecting re-transmitted signals from other flow computers providing a resultant rate and total. The instrument displays the flow rate and total for each channel as well as the result.

The frequency input is compatible with a wide range of frequency signals, including millivolt signals, reed switches, Namur proximity switches and pulse trains via its smart front-panel program selection. The analog input can be scaled and have filtering, non-linear correction and cutoff points applied to the signal.

Calculations

For frequency inputs the calculation of totals are exact as the instrument collects all pulses detected on each channel.

$$\text{channel total} = \text{pulses} / k\text{-factor}$$

The flow rates are derived from an accurately measured frequency:

$$\text{channel flow} = \text{frequency} / k\text{-factor}$$

For analog inputs, to derive the flow rate, the analog input is normalised to a value (A) between 0 and 1.

$$\text{channel flow} = (V_f\text{max} - V_f\text{min})A + V_f\text{min}$$

$$\text{channel total} = \int (\text{channel flow} \cdot \Delta t)$$

The resultant values are then:

$$\text{ADD result} = \text{channel 1} + \text{channel 2}$$

$$\text{SUB result} = \text{channel 1} - \text{channel 2}$$

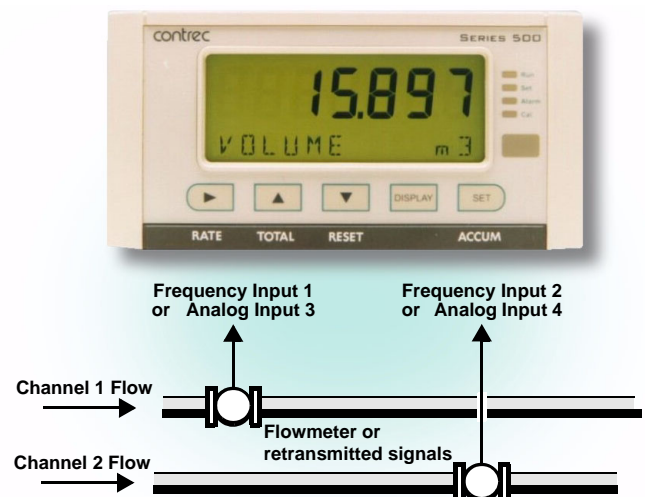

Displayed Information

The front panel display shows the current values of the input variables and the results of the calculations. A list of the variables for this application and their type (total or rate) is shown at the end of this document.

The instrument can be supplied with a real-time clock for data logging of over 1000 entries of the variables as displayed on the main menu.

Communications

There are three communication ports available as follows:

- RS-232 port (standard)
- RS-485 port (advanced option)
- Infra-red port (on front panel)

The ports are available for remote data reading, printouts and for initial application loading of the instrument.

Isolated Outputs

The opto-isolated outputs can re-transmit any main menu variable. The type of output is determined by the nature of the assigned variable. Totals are output as pulses and rates are output as 4-20mA signals. One output is standard, a second output is available as an option.

Relay Outputs

The relay alarms can be assigned to any of the main menu variables of a rate type. The alarms can be fully configured including hysteresis. Two relays are standard with an additional two available in the advanced option.

Software Configuration

The instrument can be further tailored to suit specific application needs including units of measurement, custom tags, second language or access levels. A distributor can configure these requirements before delivery.

Instrument parameters including units of measurement can be programmed in the field, according to the user-access levels assigned to parameters by the distributor.

All set-up parameters, totals and logged data are stored in non-volatile memory with at least 30 years retention.

Terminal Designations

Terminal Label	Designation	Comment
1	FINP 1+	Frequency Input 1+
2	FINP 2+	Frequency Input 2+
3	SG	Signal ground
11	AINP3 +	Analog input ch 3 (+)
12	AINP3 -	Analog input ch 3 (-)
13	AINP4 +	Analog input ch 4 (+)
14	AINP4 -	Analog input ch 4 (-)
15	Vo +	8-24 volts DC output
16	G -	DC Ground
17	Vi +	DC power input
18	SH E	Shield terminal
19	+	RS485 (+)
20	-	RS485 (-)
21	G	RS485 ground
22	1+	Switch 1
23	2+	Switch 2
24	3+	Switch 3
25	4+	Switch 4
26	C-	Signal ground
27	+	Output ch 1 (+)
28	-	Output ch 1 (-)
29	+	Output ch 2 (+)
30	-	Output ch 2 (-)
31	RC	Relay common
32	R1	Relay 1
33	R2	Relay 2
34	R3	Relay 3
35	R4	Relay 4
E	E	Mains ground
N	N	Mains neutral
A	A	Mains active
RS232 port		9-pin serial port

Dimension Drawings

Part Number

515-XXXXXX-FA03
see **Product Codes** to select required features

Default Application software:
515-FA03-000000

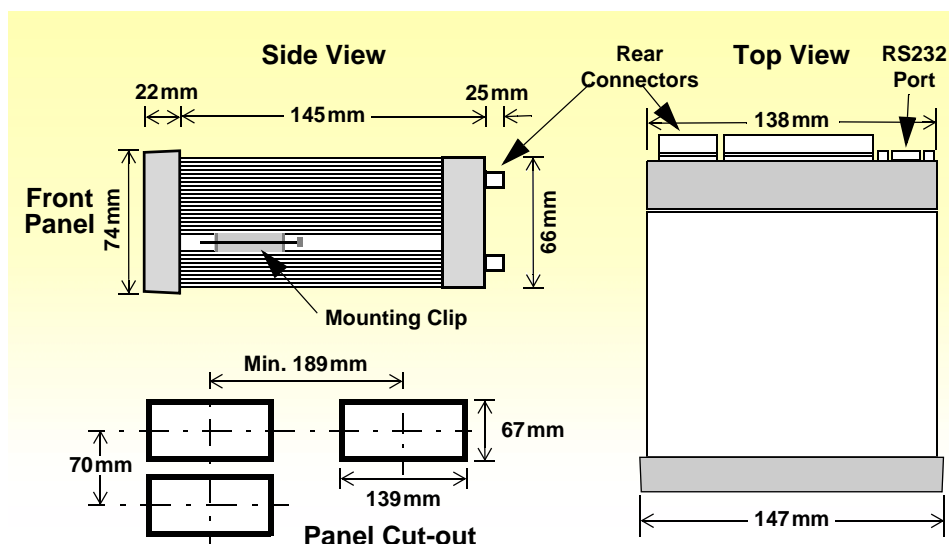

Specifications

General

Operating Environment

Temperature	-20°C to +60°C (conformal coating) +5°C to +40°C (no coating)
Humidity	0 to 95% non condensing (conformal coating) 5% to 85% non condensing (no coating)
Power Supply	95...135 V AC or 190...260 V AC or 12...28 V DC
Consumption	Typically 6W
Protection	Sealed to IP65 (Nema 4X) when panel mounted
Dimensions	147mm (5.8") width 74mm (2.9") height 167mm (6.6") depth

Display

Type	Backlit LCD with 7-digit numeric display and 11-character alphanumeric display
Digits	15.5mm (0.6") high
Characters	6mm (0.24") high
LCD Backup	Last data visible for 15min after power down
Update Rate	0.3 second

Non-volatile Memory

Retention	> 30 years
Data Stored	Setup, Totals and Logs

Approvals

Interference	CE compliance
Enclosure	ATEX, FM, CSA and SAA approved enclosures available for hazardous areas

Real Time Clock (Optional)

Battery Type	3 volts Lithium button cell (CR2032)
Battery Life	5 years (typical)

Inputs

Frequency Input (General)

Range	0 to 10kHz
Overvoltage	30V maximum
Update Time	0.3 sec
Cutoff frequency	Programmable (default at 0.25Hz)
Configuration	Pulse, coil or NPS input
Non-linearity	Up to 10 correction points

Pulse

Signal Type	CMOS, TTL, open collector, reed switch
Threshold	1.3 volts

Coil

Signal Type	Turbine and sine wave
Sensitivity	15mV p-p minimum

NPS

Signal Type	NPS sensor to Namur standard
--------------------	------------------------------

Analog Input (General)

Overcurrent	100mA absolute maximum rating
Update Time	< 1.0 sec
Configuration	4-20mA, 0-5V and 1-5V input
Non-linearity	Up to 20 correction points (flow inputs)

4-20mA Input

Impedance	100ohms (to common signal ground)
Accuracy	0.05% full scale (20°C) 0.1% (full temperature range, typical)

0-5 or 1-5 Volts Input

Impedance	10Mohms (to common signal ground)
Accuracy	0.05% full scale (20°C) 0.1% (full temperature range, typical)

Logic Inputs

Signal Type	CMOS, TTL, open collector, reed switch
Overvoltage	30V maximum

Outputs

Relay Output

No. of Outputs	2 relays plus 2 optional relays
Voltage	250 volts AC, 30 volts DC maximum
Current	3A maximum

Communication Ports

Ports	RS-232 port RS-485 port (optional) Infra-red port
Baud Rate	2400 to 19200 baud
Parity	Odd, even or none
Stop Bits	1 or 2
Protocols	ASCII, Modbus RTU, Printer (RS232)

Transducer Supply

Voltage	8 to 24 volts DC, programmable
Current	70mA @ 24V, 120mA @ 12V maximum
Protection	Power limited output

Isolated Output

No. of Outputs	1 configurable output (plus 1 optional)
Configuration	Pulse/Digital or 4-20mA output

Pulse/Digital Output

Signal Type	Open collector
Switching	200mA, 30 volts DC maximum
Saturation	0.8 volts maximum
Pulse Width	Programmable: 10, 20, 50, 100, 200 or 500ms

4-20mA Output

Supply	9 to 30 volts DC external
Resolution	0.05% full scale
Accuracy	0.05% full scale (20°C) 0.1% (full temperature range, typical)

Important: Specifications are subject to change without notice.

Ordering Information

Customer:

Purchase Order Ref:

If custom settings are required prior to delivery, please specify preferences in the table below. Include this form with the purchase order and specify "Custom Selection Attached". (Units of measurement can be changed in field if required).

Product Codes

Model	Supplementary Code						Description
515	- FA03						
Enclosure	1						Panel mount enclosure
	2						Field mount enclosure (not yet available)
	3/5						Explosion proof Ex410 with metric glands (5 specifies heater version)
	4/6						Explosion proof Ex410 with NPT glands (6 specifies heater version)
Output Options	0						Basic – 9 way DB RS232 serial port, 2 relays, 1 isolated 4-20 or pulse output and 4 logic inputs
	1						Advanced - also includes RS485 port, 2 extra relays, 1 extra isolated output and Real-time clock for printer output and logging
CPU Type	1						Standard - ASCII and printer protocol, extra logging (1000+ logs)
Power Supply	E						For 220/240 VAC
	A						For 110/120 VAC
	D						For DC power only 12-28 VDC
Display Panel Option	F						Fully optioned (with backlight, LCD backup and Infra-Red comms port)
PCB Protection	C						Conformal coating - required for maximum environmental operating range. Recommended to avoid damage from moisture and corrosion.
	N						None - suitable for IEC standard 654-1 Climatic Conditions up to Class B2 (Heated and/or cooled enclosed locations)
Application Pack Number					FA03		Defines the application software to be loaded into the instrument

Example full product part number is 515.111EFC-FA03 (This is the number used for placing orders).

Main Menu Variables

Main Menu Variables	Default Units	Preferred Units	Variable Type
Total 1	MWh		Total
Flowrate 1	MW		Rate
Total 2	MWh		Total
Flowrate 2	MW		Rate
ResultingTotal	MWh		Total
Resulting Flowrate	MW		Rate

Please specify the preferred units of measurement.



500 Series in Ex410 Enclosure

www.contrec.com.au

Contrec Pty Ltd

22 Hall Street Hawthorn East
Victoria 3123 AUSTRALIA
Tel: +61 3 9804 4200 Fax: +61 3 9822 8329
Email: sales@contrec.com.au

Contrec Europe Limited

PO Box 436 Sowerby Bridge,
West Yorkshire HX6 3YA, UK
Tel: +44 1422 829 940 Fax +44 1422 829 941
Email: sales@contrec.co.uk

Contrec - USA, LLC

916 Belcher Drive, Pelham AL 35124 USA
Tel: (205) 685 3000 Fax: (205) 685 3001
Email: contrec@contrec-usa.com

A Delft Instruments company