

Application GN13

Natural Gas (SGERG / AGA-8 Gross) Flow Computer

for Stacked DP Mass
Flowmeters

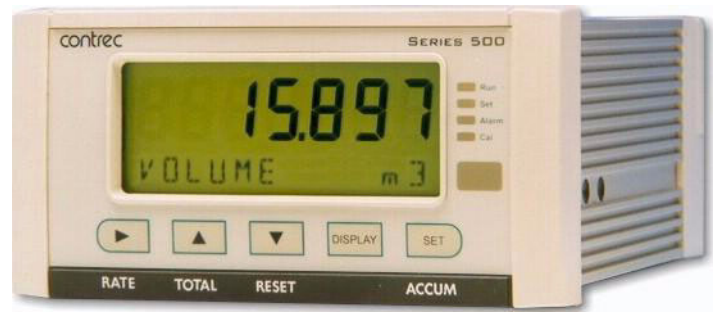

Features

- Tailored for differential pressure mass flowmeters with single or stacked transmitters
- Generic differential pressure flow calculations
- Uses SGERG (AGA-8 Gross Method) Natural Gas compressibility calculations
- For Natural and Coke-Oven Gases
- Allows for square law and non-linear correction
- Selection of second language and user tags
- RTC logging with over 1000 entries
- Infra-red communications port on front panel
- Pulse width and scaling of pulse output
- 4-20mA retransmission
- Selectable protocols on serial ports including Modbus RTU and Printer output
- Front panel adjustment of 8-24V DC output voltage
- Backlit display
- LCD backup



Overview

The 515 GN13 application measures the volume, mass and gross heat content of natural gas. The instrument uses single or stacked differential pressure mass flow inputs and analog temperature and pressure sensor inputs.

The instrument calculates the flow according to generic differential pressure equations and incorporates the conditions at which the flowmeter was calibrated.

The SGERG calculation (AGA-8 Gross Characterization Method) is used to obtain accurate values of density and compressibility factors for the flow calculations.

Calculations

The gas density and compressibility factor calculations are based on the SGERG (AGA-8 Gross) equations. The calculations are valid for the region:

$$-8.0^{\circ}\text{C} < t < 62.0^{\circ}\text{C} \quad P < 12\text{MPa}$$

$$17^{\circ}\text{F} < t < 143.0^{\circ}\text{F} \quad P < 1740\text{psia}$$

Formulas

$$\text{Volume flow} = M_{\text{flow}} / \rho_{\text{flow}}$$

$$\text{Corrected flow} = M_{\text{flow}} / \rho_{\text{ref}}$$

$$\text{Heat flow} = M_{\text{flow}} \cdot H_m$$

where:

M_{flow} = mass flow

ρ_{flow} = density at flow conditions

ρ_{ref} = density at reference conditions

H_m = mass gross heating value

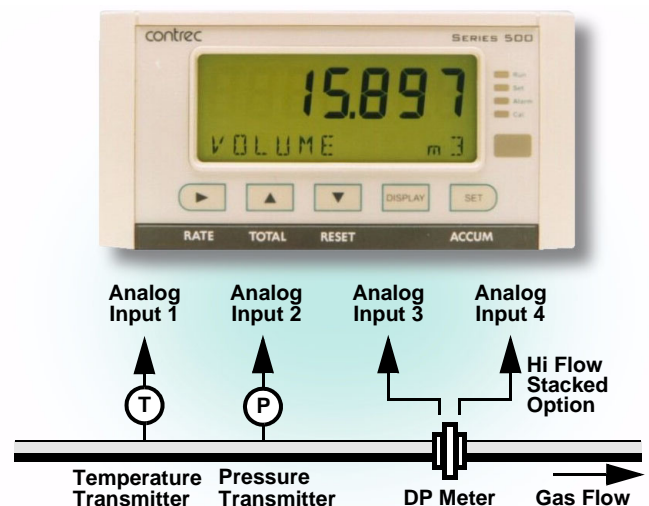

Displayed Information

The front panel display shows the current values of the input variables and the results of the calculations. A list of the variables for this application and their type (total or rate) is shown at the end of this document.

The instrument can be supplied with a real-time clock for data logging of over 1000 entries of the variables as displayed on the main menu.

Communications

There are three communication ports available as follows:

- RS-232 port (standard)
- RS-485 port (advanced option)
- Infra-red port (on front panel)

The ports are available for remote data reading, printouts and for initial application loading of the instrument.

Isolated Outputs

The opto-isolated outputs can re-transmit any main menu variable. The type of output is determined by the nature of the assigned variable. Totals are output as pulses and rates are output as 4-20mA signals. One output is standard, a second output is available as an option.

Relay Outputs

The relay alarms can be assigned to any of the main menu variables of a rate type. The alarms can be fully configured including hysteresis. Two relays are standard with an additional two available in the advanced option.

Software Configuration

The instrument can be further tailored to suit specific application needs including units of measurement, custom tags, second language or access levels. A distributor can configure these requirements before delivery.

Instrument parameters including units of measurement can be programmed in the field, according to the user-access levels assigned to parameters by the distributor.

All set-up parameters, totals and logged data are stored in non-volatile memory with at least 30 years retention.

Temperature and Pressure Input Types

Temperature sensor input can be either PT100, PT500, 4-20mA, 0-5V or 1-5V signals. Pressure sensor input can be either 4-20mA, 0-5V or 1-5V signals.

Terminal Designations

Terminal Label	Designation	Comment
3	SG -	Signal ground
5	EXC V 2+	Excitation Term 2+
7	AINP1 +	Analog input ch 1 (+)
8	-	Analog input ch 1 (-)
9	AINP2 +	Analog input ch 2 (+)
10	-	Analog input ch 2 (-)
11	AINP3 +	Analog input ch 3 (+)
12	-	Analog input ch 3 (-)
13	AINP4 +	Analog input ch 4 (+)
14	-	Analog input ch 4 (-)
15	Vo +	8-24 volts DC output
16	G -	DC Ground
17	Vi +	DC power input
18	SH E	Shield terminal
19	+	RS485 (+)
20	-	RS485 (-)
21	G	RS485 ground
22	1+	Switch 1
23	2+	Switch 2
24	3+	Switch 3
25	4+	Switch 4
26	C-	Signal ground
27	+	Output ch 1 (+)
28	-	Output ch 1 (-)
29	+	Output ch 2 (+)
30	-	Output ch 2 (-)
31	RC	Relay common
32	R1	Relay 1
33	R2	Relay 2
34	R3	Relay 3
35	R4	Relay 4
E	E	Mains ground
N	N	Mains neutral
A	A	Mains active
RS232 port		9-pin serial port

Dimension Drawings

Part Number

515-XXXXXX-GN13
see **Product Codes** to select required features

Default Application software:
515-GN13-000000

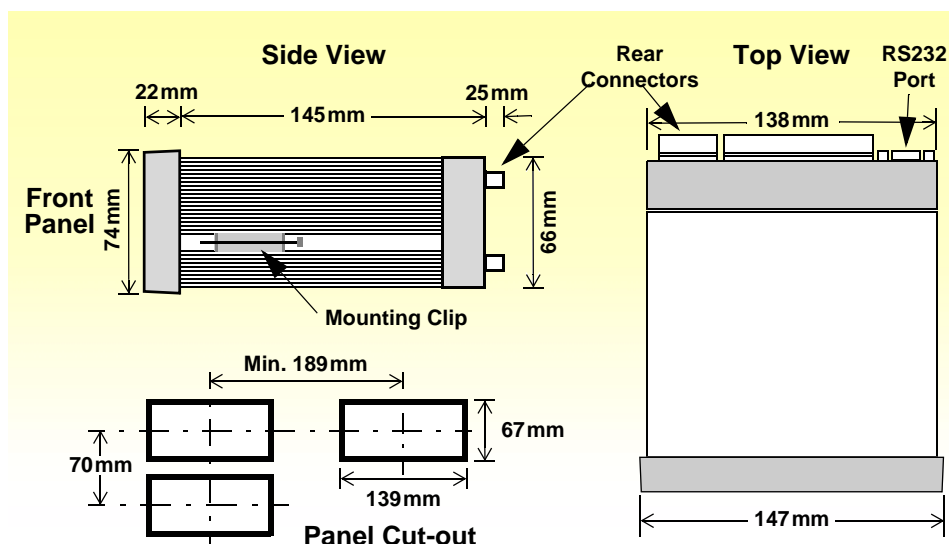

Specifications

General

Operating Environment

Temperature	-20°C to +60°C (conformal coating) +5°C to +40°C (no coating)
Humidity	0 to 95% non condensing (conformal coating) 5% to 85% non condensing (no coating)
Power Supply	95...135 V AC or 190...260 V AC or 12...28 V DC
Consumption	Typically 6W
Protection	Sealed to IP65 (Nema 4X) when panel mounted
Dimensions	147mm (5.8") width 74mm (2.9") height 167mm (6.6") depth

Display

Type	Backlit LCD with 7-digit numeric display and 11-character alphanumeric display
Digits	15.5mm (0.6") high
Characters	6mm (0.24") high
LCD Backup	Last data visible for 15min after power down
Update Rate	0.3 second

Non-volatile Memory

Retention	> 30 years
Data Stored	Setup, Totals and Logs

Approvals

Interference	CE compliance
Enclosure	ATEX, FM, CSA and SAA approved enclosures available for hazardous areas

Real Time Clock (Optional)

Battery Type	3 volts Lithium button cell (CR2032)
Battery Life	5 years (typical)

Inputs

Analog Input (General)

Overcurrent	100mA absolute maximum rating
Update Time	< 1.0 sec
Configuration	RTD, 4-20mA, 0-5V and 1-5V input
Non-linearity	Up to 20 correction points (flow inputs)

RTD Input

Sensor Type	PT100 & PT500 to IEC 751
Connection	Four Wire
Range	-100°C to 300°C
Accuracy	0.1°C typical

4-20mA Input

Impedance	100ohms (to common signal ground)
Accuracy	0.05% full scale (20°C) 0.1% (full temperature range, typical)

0-5 or 1-5 Volts Input

Impedance	10Mohms (to common signal ground)
Accuracy	0.05% full scale (20°C) 0.1% (full temperature range, typical)

Logic Inputs

Signal Type	CMOS, TTL, open collector, reed switch
Overvoltage	30V maximum

Outputs

Relay Output

No. of Outputs	2 relays plus 2 optional relays
Voltage	250 volts AC, 30 volts DC maximum
Current	3A maximum

Communication Ports

Ports	RS-232 port RS-485 port (optional) Infra-red port
Baud Rate	2400 to 19200 baud
Parity	Odd, even or none
Stop Bits	1 or 2
Protocols	ASCII, Modbus RTU, Printer (RS232)

Transducer Supply

Voltage	8 to 24 volts DC, programmable
Current	70mA @ 24V, 120mA @ 12V maximum
Protection	Power limited output

Isolated Output

No. of Outputs	1 configurable output (plus 1 optional)
Configuration	Pulse/Digital or 4-20mA output

Pulse/Digital Output

Signal Type	Open collector
Switching	200mA, 30 volts DC maximum
Saturation	0.8 volts maximum
Pulse Width	Programmable: 10, 20, 50, 100, 200 or 500ms

4-20mA Output

Supply	9 to 30 volts DC external
Resolution	0.05% full scale
Accuracy	0.05% full scale (20°C) 0.1% (full temperature range, typical)

Important: Specifications are subject to change without notice.

Ordering Information

Customer:

Purchase Order Ref:

If custom settings are required prior to delivery, please specify preferences in the table below. Include this form with the purchase order and specify "Custom Selection Attached". (Units of measurement can be changed in field if required).

Product Codes

Model	Supplementary Code						Description
515	- GN13						
Enclosure	1						Panel mount enclosure
	2						Field mount enclosure (not yet available)
	3/5						Explosion proof Ex410 with metric glands (5 specifies heater version)
	4/6						Explosion proof Ex410 with NPT glands (6 specifies heater version)
Output Options	0						Basic – 9 way DB RS232 serial port, 2 relays, 1 isolated 4-20 or pulse output and 4 logic inputs
	1						Advanced - also includes RS485 port, 2 extra relays, 1 extra isolated output and Real-time clock for printer output and logging
CPU Type	1						Standard - ASCII and printer protocol, extra logging (1000+ logs)
Power Supply		E					For 220/240 VAC
		A					For 110/120 VAC
		D					For DC power only 12-28 VDC
Display Panel Option		F					Fully optioned (with backlight, LCD backup and Infra-Red comms port)
PCB Protection			C				Conformal coating - required for maximum environmental operating range. Recommended to avoid damage from moisture and corrosion.
			N				None - suitable for IEC standard 654-1 Climatic Conditions up to Class B2 (Heated and/or cooled enclosed locations)
Application Pack Number					GN13		Defines the application software to be loaded into the instrument

Example full product part number is 515.111EFC-GN13 (This is the number used for placing orders).

Main Menu Variables

Main Menu Variables	Default Units	Preferred Units	Variable Type
Volume	m ³		Total
Volume Flowrate	m ³ /min		Rate
Corrected Volume	m ³		Total
Corrected Flowrate	m ³ /min		Rate
Heat	GJ		Total
Heat Flowrate	GJ/h		Rate
Mass	kg		Total
Mass Flowrate	kg/min		Rate
Temperature	Deg C		Rate
Pressure	MPa		Rate
Compressibility Factor	---	---	Rate

Please specify the preferred units of measurement.



500 Series in Ex410 Enclosure

www.contrec.com.au

Contrec Pty Ltd

22 Hall Street Hawthorn East
Victoria 3123 AUSTRALIA
Tel: +61 3 9804 4200 Fax: +61 3 9822 8329
Email: sales@contrec.com.au

Contrec Europe Limited

PO Box 436 Sowerby Bridge,
West Yorkshire HX6 3YA, UK
Tel: +44 1422 829 940 Fax +44 1422 829 941
Email: sales@contrec.co.uk

Contrec - USA, LLC

916 Belcher Drive, Pelham AL 35124 USA
Tel: (205) 685 3000 Fax: (205) 685 3001
Email: contrec@contrec-usa.com

A Delft Instruments company