

Application HC03

Heat Calculator Flow Computer

for Stacked DP Mass
Flowmeters

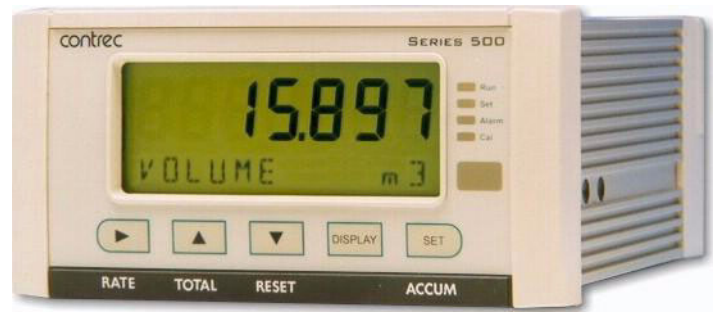

Features

- Suited for heating and/or cooling operation
- Uses IAPWS-IF97 to determine water properties
- Selection of common industry fluids using internal tables
- Facility for user defined Enthalpy and Density table
- Tailored for differential pressure mass meters with single or stacked transmitters
- Generic differential pressure flow calculations
- Flow meter can be located in feed or return line
- Allows for square law and non-linear correction
- Selection of second language and user tags
- RTC logging with over 1000 entries
- Infra-red communications port on front panel
- Pulse width and scaling of pulse output
- 4-20mA retransmission
- Selectable protocols on serial ports including Modbus RTU and Printer output
- Front panel adjustment of 8-24V DC output voltage
- Backlit display
- LCD backup



Overview

The 515 HC03 application measures the volume, mass and energy content of fluid in a heating or cooling system by using single or stacked differential pressure mass flow inputs in conjunction with feed and return temperature inputs.

A selection of fluid types and modes makes it suitable for many heating/cooling applications. The instrument calculates the flow according to generic differential pressure equations and incorporates the conditions at which the flowmeter was calibrated.

The instrument calculates the mass flow and energy according to the IAPWS Industrial Formulation (1997) when the fluid type is water, while internal enthalpy and density tables are used for the selection of other industry fluids.

Calculations

This instrument can calculate the mass and energy for the following common industry fluids:

- Water
- Glycol (35% Solution)
- Brine (27% CaCl₂)
- TYFOXIT F20
- TYFOXIT F40
- Essotherm 500 / Thermaloil
- THERMINOL 55
- User Custom Fluid

Formulas

$$\text{Volume flow} = \text{Mass flow} / \rho_{\text{flow}}$$

$$\text{Power} = \text{Mass flow} \times (h_{TF} - h_{TR})$$

where:

ρ_{flow} = density at flow conditions

h_{TF} = Specific enthalpy at feed temperature

h_{TR} = Specific enthalpy at return temperature

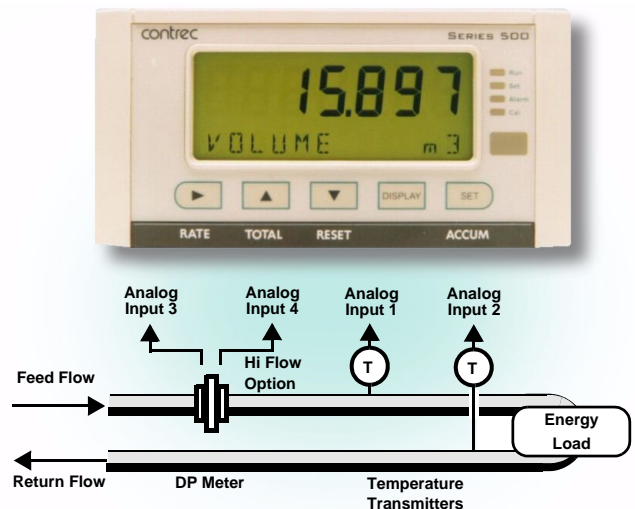

Displayed Information

The front panel display shows the current values of the input variables and the results of the calculations. A list of the variables for this application and their type (total or rate) is shown at the end of this document.

The instrument can be supplied with a real-time clock for data logging of over 1000 entries of the variables as displayed on the main menu.

Communications

There are three communication ports available as follows:

- RS-232 port (standard)
- RS-485 port (advanced option)
- Infra-red port (on front panel)

The ports are available for remote data reading, printouts and for initial application loading of the instrument.

Isolated Outputs

The opto-isolated outputs can re-transmit any main menu variable. The type of output is determined by the nature of the assigned variable. Totals are output as pulses and rates are output as 4-20mA signals. One output is standard, a second output is available as an option.

Relay Outputs

The relay alarms can be assigned to any of the main menu variables of a rate type. The alarms can be fully configured including hysteresis. Two relays are standard with an additional two available in the advanced option.

Software Configuration

The instrument can be further tailored to suit specific application needs including units of measurement, custom tags, second language or access levels. A distributor can configure these requirements before delivery.

Instrument parameters including units of measurement can be programmed in the field, according to the user access levels assigned to parameters by the distributor.

All set-up parameters, totals and logged data are stored in non-volatile memory with at least 30 years retention.

Temperature Input Types

Temperature sensor inputs can be either PT100, PT500, 4-20mA, 0-5V or 1-5V signals.

Terminal Designations

Terminal Label	Designation	Comment
3	SG -	Signal ground
5	EXC V 2+	Excitation Term 2+
6	EXC V 3+	Excitation Term 3+
7	AINP1 +	Analog input ch 1 (+)
8	-	Analog input ch 1 (-)
9	AINP2 +	Analog input ch 2 (+)
10	-	Analog input ch 2 (-)
11	AINP3 +	Analog input ch 3 (+)
12	-	Analog input ch 3 (-)
13	AINP4 +	Analog input ch 4 (+)
14	-	Analog input ch 4 (-)
15	Vo +	8-24 volts DC output
16	G -	DC Ground
17	Vi +	DC power input
18	SH E	Shield terminal
19	RS485 +	RS485 (+)
20	-	RS485 (-)
21	G	RS485 ground
22	1+	Switch 1
23	2+	Switch 2
24	3+	Switch 3
25	4+	Switch 4
26	C-	Signal ground
27	OUT 1 +	Output ch 1 (+)
28	-	Output ch 1 (-)
29	OUT 2 +	Output ch 2 (+)
30	-	Output ch 2 (-)
31	RC	Relay common
32	R1	Relay 1
33	R2	Relay 2
34	R3	Relay 3
35	R4	Relay 4
E	AC MAINS E	Mains ground
N	N	Mains neutral
A	A	Mains active
RS232 port		9-pin serial port

Dimension Drawings

Part Number

515-XXXXXX-HC03
see **Product Codes** to select required features

Default Application software:
515-HC03-000000

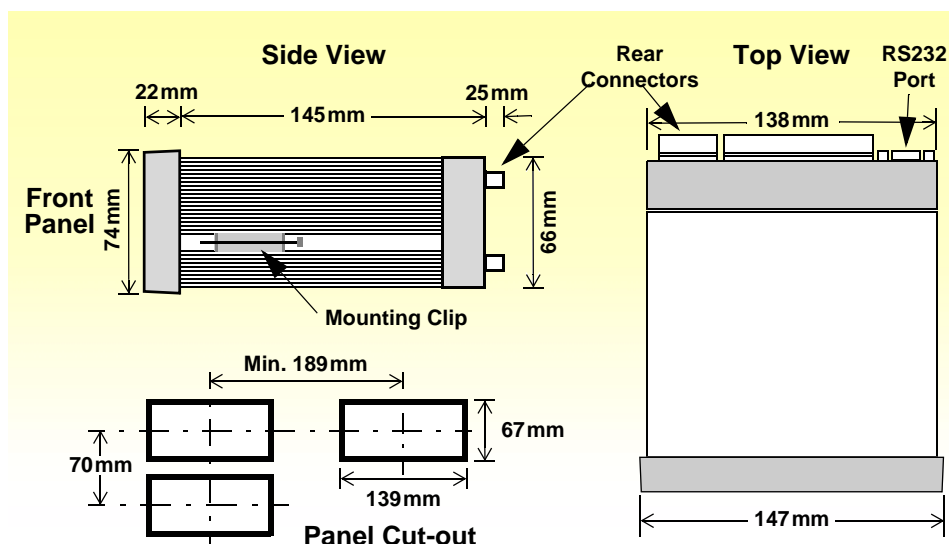

Specifications

General

Operating Environment

Temperature	-20°C to +60°C (conformal coating) +5°C to +40°C (no coating)
Humidity	0 to 95% non condensing (conformal coating) 5% to 85% non condensing (no coating)
Power Supply	95...135 V AC or 190...260 V AC or 12...28 V DC
Consumption	Typically 6W
Protection	Sealed to IP65 (Nema 4X) when panel mounted
Dimensions	147mm (5.8") width 74mm (2.9") height 167mm (6.6") depth

Display

Type	Backlit LCD with 7-digit numeric display and 11-character alphanumeric display
Digits	15.5mm (0.6") high
Characters	6mm (0.24") high
LCD Backup	Last data visible for 15min after power down
Update Rate	0.3 second

Non-volatile Memory

Retention	> 30 years
Data Stored	Setup, Totals and Logs

Approvals

Interference	CE compliance
Enclosure	ATEX, FM, CSA and SAA approved enclosures available for hazardous areas

Real Time Clock (Optional)

Battery Type	3 volts Lithium button cell (CR2032)
Battery Life	5 years (typical)

Inputs

Analog Input (General)

Overcurrent	100mA absolute maximum rating
Update Time	< 1.0 sec
Configuration	RTD, 4-20mA, 0-5V and 1-5V input
Non-linearity	Up to 20 correction points (flow inputs)

RTD Input

Sensor Type	PT100 & PT500 to IEC 751
Connection	Four Wire
Range	-100°C to 300°C
Accuracy	0.1°C typical

4-20mA Input

Impedance	100ohms (to common signal ground)
Accuracy	0.05% full scale (20°C) 0.1% (full temperature range, typical)

0-5 or 1-5 Volts Input

Impedance	10Mohms (to common signal ground)
Accuracy	0.05% full scale (20°C) 0.1% (full temperature range, typical)

Logic Inputs

Signal Type	CMOS, TTL, open collector, reed switch
Overvoltage	30V maximum

Outputs

Relay Output

No. of Outputs	2 relays plus 2 optional relays
Voltage	250 volts AC, 30 volts DC maximum (solid state relays use AC only)
Current	3A maximum

Communication Ports

Ports	RS-232 port RS-485 port (optional) Infra-red port
Baud Rate	2400 to 19200 baud
Parity	Odd, even or none
Stop Bits	1 or 2
Protocols	ASCII, Modbus RTU, Printer

Transducer Supply

Voltage	8 to 24 volts DC, programmable
Current	70mA @ 24V, 120mA @ 12V maximum
Protection	Power limited output

Isolated Output

No. of Outputs	1 configurable output (plus 1 optional)
Configuration	Pulse/Digital or 4-20mA output

Pulse/Digital Output

Signal Type	Open collector
Switching	200mA, 30 volts DC maximum
Saturation	0.8 volts maximum
Pulse Width	Programmable: 10, 20, 50, 100, 200 or 500ms

4-20mA Output

Supply	9 to 30 volts DC external
Resolution	0.05% full scale
Accuracy	0.05% full scale (20°C) 0.1% (full temperature range, typical)

Important: Specifications are subject to change without notice.

Ordering Information

Product Codes

Model	Supplementary Code						Description
515	- HC03						
Enclosure	1						Panel mount enclosure
	2						Field mount enclosure (not yet available)
	3/5						Explosion proof Ex410 with metric glands (5 specifies heater version)
	4/6						Explosion proof Ex410 with NPT glands (6 specifies heater version)
Output Options	0						4 logic inputs, 1 isolated output, 2 relays (only relay type 1 is available), RS232 (DB9) communication port
	1						4 logic inputs, 2 isolated outputs, 4 relays, real-time clock data logging, RS232 (DB9) and RS485 communication ports
	2/3						4 logic inputs, 2 isolated outputs, 4 relays, real-time clock data logging, RS232 (DB9) and Ethernet/RF communication ports (not yet available)
Relay Type	1						Electromechanical relays only
	2						2 electromechanical and 2 solid state relays
	3						Solid state relays only (not yet available)
Power Supply	E						For 220/240 VAC
	A						For 110/120 VAC
	D						For DC power only 12-28 VDC
Display Panel Option		F					Fully optioned (with backlight, LCD backup and Infra-Red comms port)
PCB Protection			C				Conformal coating - required for maximum environmental operating range. Recommended to avoid damage from moisture and corrosion.
			N				None - suitable for IEC standard 654-1 Climatic Conditions up to Class B2 (Heated and/or cooled enclosed locations)
Application Pack Number			HC03				Defines the application software to be loaded into the instrument

Example full product part number is 515.111EFC-HC03 (This is the number used for placing orders).

Main Menu Variables

Main Menu Variables	Default Units	Preferred Units	Variable Type
Energy	MWh		Total
Power	MW		Rate
Volume	m ³		Total
Volume Flowrate	m ³ /min		Rate
Mass	kg		Total
Mass Flowrate	kg/min		Rate
Feed Temperature	Deg C		Rate
Return Temperature	Deg C		Rate
Differential Temperature	Deg C		Rate

Please specify the preferred units of measurement.



500 Series in Ex410 Enclosure

www.contrec.com.au

Contrec Pty Ltd

22 Hall Street Hawthorn East
Victoria 3123 AUSTRALIA
Tel: +61 3 9804 4200 Fax: +61 3 9822 8329
Email: sales@contrec.com.au

Contrec Europe Limited

PO Box 436 Sowerby Bridge,
West Yorkshire HX6 3YA, UK
Tel: +44 1422 829 940 Fax +44 1422 829 941
Email: sales@contrec.co.uk

Contrec - USA, LLC

916 Belcher Drive, Pelham AL 35124 USA
Tel: (205) 685 3000 Fax: (205) 685 3001
Email: contrec@contrec-usa.com