

Field Mounting Rate Totaliser

Model 202D

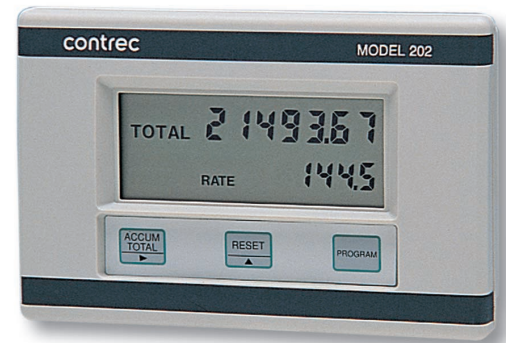

Features

- ATEX, CSA_{US/C} approved
- Displays Rate, Total and Accumulated Total
- Battery, Loop or DC powered
- Intrinsically safe version - 202Di
- Watertight to IP67 (Nema 4X)
- Wall, pipe, panel or flowmeter mounting
- Fully programmable
- 4-20mA output
- High & low alarms
- CE compliant



Overview

The 202D Field Mounting Rate Totaliser requires no external power and is designed to operate with turbine, positive displacement and paddlewheel flowmeters in applications such as irrigation systems and pipelines, and as a replacement for mechanical registers.

Battery, Loop or DC powered

The standard 202D is powered by long-life lithium batteries. Alternatively, the 202D can be loop powered via an optional 4-20mA output, or powered from a 9-28 Volts DC supply.

For installation in hazardous areas a certified intrinsically safe version is available. The intrinsic safety approvals cover both the 4-20mA output and relay outputs, in addition to the input circuits.

Watertight field mounting enclosure

The 202D Rate Totaliser is housed in a rugged yet attractive IP67 (Nema 4X) rated polycarbonate enclosure which is completely watertight.

This enables the instrument to be mounted directly on the flowmeter, panel mounted or wall mounted using a special universal bracket. A 2" pipe mounting bracket is also available.

Fully user programmable

K-factor, decimal point positions, filter constants and time base are fully user programmable.

Rate and Totals can also be displayed in different engineering units such as gallons per minute and barrels.

Model 202D

Field Mounting Rate Totaliser

The 202D is field proven in thousands of installations throughout the world.

Frequency to Current conversion

The 202D loop powered Rate Totaliser makes an excellent Frequency to Current Converter particularly for low frequency inputs from positive displacement or turbine flowmeters.

Because the 202D calculates the flow rate by measuring the time interval between input pulses, it is able to provide a very stable and accurate 4-20mA output for low frequency inputs.

Non-Linearity Correction

The 202D is available with 10 point non-linear correction.

Separate K-factors and frequency points can be programmed to compensate for changes in K-factor with flowrates.

Non-linearity correction is only recommended for applications where precise measurements are required and flowmeter calibration certificates are available.

Note that this option increases the display update rate to 1 second in battery powered versions.

Versions Available

Battery powered

The battery version of the 202D is designed for operation where external power sources are not available. It derives its power from two lithium battery packs which provide sufficient power for up to 5 years.

Low battery power condition is signalled to the operator by a message on the LCD and battery replacement is easily carried out in the field even in hazardous areas.

4-20mA Output Loop powered

The 4-20mA output version draws its operating power from the 4-20mA loop and uses lithium batteries for back-up if the 4-20mA loop is interrupted.

The instrument provides a 2-wire re-transmission of the flow rate. Both the 4mA and 20mA points are fully programmable so that the output can span across the entire range or, alternatively, across a small section of the operating range.

DC powered

The DC powered version will operate from an external power source between 9 and 28 Volts and draws no more than 4mA. This enables the 202D to be powered from AC mains adaptors and eliminates the need to run mains voltages in the field.

Lithium batteries provide back-up if the DC power is interrupted.

Solid State Relay Outputs

Both the 4-20mA output version and the DC powered version are provided with two solid state relay outputs. The solid state relays provide high and low flow rate alarms or, alternatively, a pulse output and a low flow rate alarm. The outputs can sink up to 200mA and can be used to power external relays, audible alarms or counters. The outputs are internally protected against voltage spikes caused by relays and coils.

Both outputs are separately isolated via opto isolators.

The switching points can be programmed during the set-up mode. If programmed for a pulse output, the pulse can be selected as either unscaled (raw pulse input) or scaled. The maximum pulse frequency is 500mSec with a pulse width which is automatically set as:

1mSec if output > 50Hz
10mSec if output = 5...50Hz
100mSec if output < 5Hz



Specifications



General

Display

Total: 7 digit 10mm (0.4") high LCD (continuously powered).
Note: The Resettable Total is resettable from the front panel and the Accumulated Total is displayed when the ACCUM TOT key is pressed.

Rate: 4 digit 8.5mm (0.33") high LCD (continuously powered).

K-factor Range: The pulses per unit of measure (eg. pulses/gallon) is programmable in the range 0.000001 to 999,999.

Decimal Points: Fully programmable for Rate and Total.

Time Base: Rates can be displayed in units per second, minute, hour or day.

Frequency Range: 0.01Hz to 10kHz.

Signal Type: Switch settable for sine wave (15mV P-P minimum), open collector, reed switch or pulse.

Interference: CE compliance.

Physical

Operating Temperature: -20 to 60°C.

Enclosure

Dimensions: 98mm (3.9") high x 152mm (6.0") wide x 43mm (1.7") deep.

Protection: IP67 (Nema 4X) watertight.

Cable Entry: By cable glands.

Materials: Polycarbonate and ABS.

Mounting Options

Wall: Wall mount bracket.

Pipe: A galvanised metal bracket enables the 202D to be attached to a 2" vertical or horizontal pipe.

Panel: Two mounting brackets are provided and terminals are accessible on the rear of the enclosure. *Note: The panel mount version is not watertight.*

Turbine Meter: Bottom and rear mounting stems are available for mounting the 202D directly on turbine flowmeters which have a 1" NPT or BSP boss.

Battery Powered Version

Battery Type: 2 x Lithium battery packs.

Battery Life: 5 years.

Loop Powered 4-20mA Output Version

Scale: The 4mA and 20mA points are programmable.

Resolution & Linearity: 0.05% of span.

Accuracy: 0.05% of span at 25°C.

Update Time: 0.5s.

Connection: 2 wire.

Voltage Across Output: 28V dc maximum.

Voltage Drop: 9V maximum.

Memory Backup: Lithium battery.

DC Powered / Alarm or Pulse Output Version

Outputs: 2 x solid state relay outputs suitable for driving DC solenoids or external relays. The outputs provide fully programmable high & low flow alarms or a pulse output & low alarm.

Pulse Output: Scaled or unscaled pulse output, 500Hz maximum. Pulse width depends on output frequency and varies from 100mSec to 1mSec.

Switching Power: 200mA, 30V dc maximum.

Saturation Voltage: 0.8V dc across outputs when in the "on" state.

Isolation: Both outputs are separately isolated.

DC Power Input: 9-28V @ 4mA maximum.

Memory Backup: Lithium battery.

Hazardous Area Approval (Model 202Di)

Type of Approval:

- ▶ ATEX II 2G EEx ia IIB T3.
- ▶ CSA_{US/IC} Class 1, Groups C and D.
- ▶ SAA Ex ia IIB T6.

Maximum Ambient: 60°C.

Maximum Input Parameters: (For certified IS coil or other certified IS sensors which produce a pulse output.)

U _o = 10.0V	L(ext) = 1.5H	I _i = 20mA
I _o = 9.0mA	L _i = 0mH	P _i = 320mW
C(ext) = 60uF	U _i = 24V	C _i = 0.002uF

Note: Devices such as reed switches, which can be classed as "Simple Apparatus" as defined in the Cenelec standard EN50020, can be connected to the Model 202D without additional certification.

Maximum Output Parameters:

4-20mA or Relays:	U _i = 28V
	I _i = 93mA
	P _i = 653mW

Important: Specifications are subject to change without notice.



Dimensional Diagrams

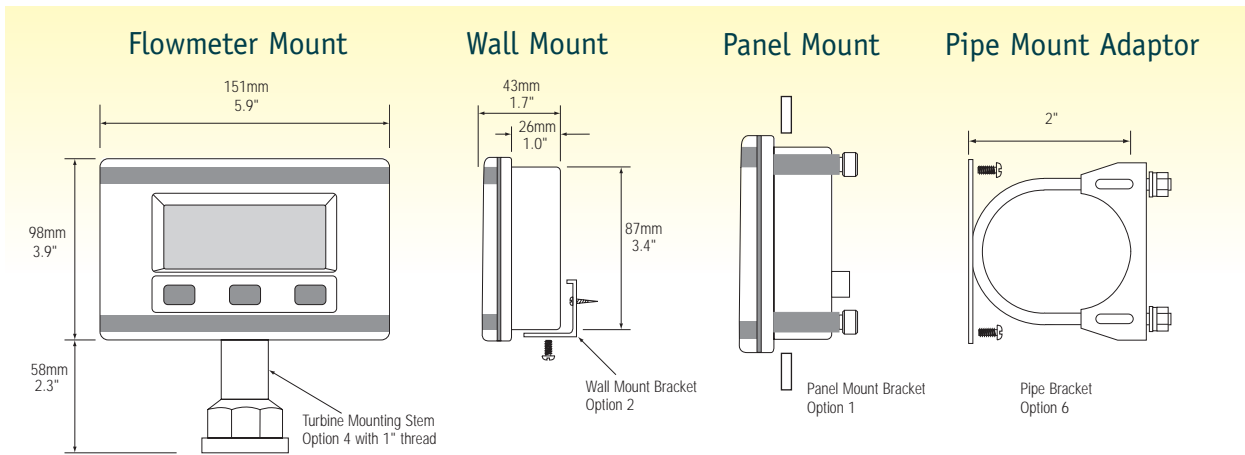

Terminal Descriptions

Common All Models	
Number	
7	Signal Input (-)
8	Signal Input (+)

DC Power Versions	
Number	
1	DC Power OV
2	DC Power +9 to 28V dc

4-20mA Output Versions	
Number	
1	4-20mA (-)
2	4-20mA (+)
3	Low Alarm (-)
4	Low Alarm (+)
5	High Alarm (-) or Pulse (-)
6	High Alarm (+) or Pulse (+)

Product Codes

Product Codes			
202D	.		Flowrate Totaliser
Intrinsic Safety	i		Intrinsically safe Not intrinsically safe
Enclosure and Mounting	0 1 2 3 4 5 6		Wall Mounting (no gland holes) Panel Mount Wall Mounting (Standard glands) Explosionproof Enclosure (USA Only) Turbine Mount (bottom) Turbine Mount (rear) Pipe Mount
Output Option	0 3 4		Battery Powered & no output option DC Powered & Alarms (Pulse Out) Loop Powered & 4-20mA out & Alarms
Hazardous Approvals		C M S	CSA US & Canadian Approval ATEX Approval SAA Australian Approval No Approvals
Linearisation		L	Standard (no linearization) Linearization

Typical Part Number: 202Di.40C or 202D.24

www.contrec.com.au

Contrec Pty. Ltd.

22 Hall Street, Hawthorn East
 Melbourne 3123 AUSTRALIA
 Tel: +61 3 9822 8966 Fax: +61 3 9822 8329
 Email: sales@contrec.com.au

Contrec Europe Limited

PO Box 436 Sowerby Bridge
 West Yorkshire HX6 3YA, UK
 Tel: +44 1422 829 940 Fax: +44 1422 829 941
 Email: sales@contrec.co.uk

Contrec - USA, LLC

916 Belcher Drive, Pelham AL 35124 USA
 Tel: (205) 685 3000 Fax: (205) 685 3001
 Email: contrec@contrec-usa.com

a Delft Instruments company