

**LOOP POWERED  
INDICATOR  
MODELS 210 & 610**



14 April 2000



# CONTENTS

<b>1. Introduction</b>	<b>3</b>
<b>2. Specification</b>	<b>4</b>
2.1 Intrinsic Safety	6
<b>3. Setting the Span &amp; Zero</b>	<b>7</b>
3.1 Trailing Zero	8
3.2 Decimal Points	8
<b>4. Installation</b>	<b>9</b>
<b>5. Model 210 Mechanical Details</b>	<b>10</b>
5.1 Wall Mounting	11
5.2 Removing the Front Panel	12
<b>6. Model 610 Mechanical Details</b>	<b>14</b>



# 1. INTRODUCTION

The Models 210 and 610 Loop Powered Indicators measure the current of a 4-20mA loop and provide a digital display of the process variable, directly in engineering units. The indicators are totally powered by the 4-20mA loop and require no external power. Potentiometers on the rear of the instruments enable the Span and Zero to be scaled and a DIP switch enables the decimal point position to be selected.

The Model 210 Indicator is fully watertight to IP67 and Nema 4X standards, and is designed for field mounting. A wall mount bracket is supplied as standard and an optional pipe mount bracket is also available.

The Model 610 Indicator is designed to mount on the outside surface of field enclosures or panels, without having to cut large rectangular holes and without requiring any space behind the panel. The indicator is only 20mm (0.8") deep and can be easily attached via four screws.

The Loop Powered Indicators incorporate a large, easily readable, 4½ digit display. The measurement resolution is 3½ digits and a trailing "0" can be switch selected for applications requiring 4½ digits.

Units of measurement can also be shown adjacent to the display. A legend sheet, with a wide range of engineering labels, is provided with each instrument, so that the appropriate label can be peeled off and placed in a special recess in the fascia.

The Model 210i is an intrinsically safe version of the Model 210 which has Cenelec approval, and CSA<sub>US/C</sub> approval which covers the USA and Canada.

## 4 Specification

# 2. SPECIFICATION

### *General*

Input Current Range:	4 to 20mA DC.
Maximum Input Current:	100mA DC.
Minimum Input Current:	3.8mA DC.
Loop Voltage Drop:	210i: 6.4 Volts at 20mA. 210 & 610: 3.8 Volts at 20mA.
Reading Update:	2 readings per second.
Display:	3½ digit with switch selectable trailing zero (4½ digits). Digits are 17.8mm (0.7") high. Decimal points are switch selectable. Under-range Indication (below -999) displays "-1". Over-range Indication (above +1999) displays "1".
Calibration Range:	Zero (4mA): Adjustable from -1999 to 1000. Span (20mA): Adjustable from 200 to 19990. Span and Zero are adjusted by 10 turn potentiometers in three ranges.
Accuracy:	+0.2% of span counts, ±1 count.
Operating Temperature:	-10° to 70°C.
Units:	The following units are provided on the legend sheet: Hz, litres/m, litres/hr, litres, gal/m, gal/h, gallons, kg/m, kg/hr, Kgs, lbs/m, lbs/hr, °F, °C, Watts, Bar, Kpa, psi.

### *Model 210*

Protection:	Sealed to Nema 4X or IP67 standards.
Cable Entry:	By cable glands.
Mounting:	Wall mount bracket supplied.
Pipe Mounting Options:	A galvanised metal bracket enables the Model 210 to be attached to a 2" vertical or horizontal pipe.
Materials:	The enclosure is an ABS and polycarbonate mixture.

***Model 610***

Materials: The facia is polycarbonate and the bezel is Noryl.  
The gasket is made from Nitril.

Mounting: Designed to mount onto the outside surface of a panel or enclosure.

## 6 Specification

### 2.1 INTRINSIC SAFETY

The Model 210i is intrinsically safe for use in hazardous areas.

CENELEC Approval  
Type:

Kema No. Ex-95.C.4785  
EEx ia IIC T6

CSA Approval  
Type:  
Temperature:

No. LR104840-4  
US/C covering the US and Canada  
-10°C to 60°C ambient

#### *Safety Parameters*

$U_i = 28V$

$I_i = 93mA$

$P_i = 650mW$

Internal capacitance  $C_i$  and inductance  $L_i$  are negligibly small.

# 3. SETTING THE SPAN & ZERO

The Span and Zero can be adjusted using trim pots on the instrument. The switches S5 to S8 should be set up as follows:

<i>Required Reading at 20mA (SPAN)</i>	<i>S5</i>	<i>S6</i>
200 - 420	on	off
400 - 1100	off	off
1000 - 1999	off	on

## *Required Reading at 4mA (ZERO)*

Normally S7 and S8 should be both "off". For Spans > 1000 where a wide adjustment of the zero is required, S7 and S8 should both be switched to "on" if the desired zero cannot otherwise be achieved.

## *To set Trim pots*

- 1 Set the input current to 4mA and adjust the Zero control until the display reads zero.
- 2 Adjust the Span to display the desired 20mA reading *less* the desired 4mA reading.
- 3 Adjust the Zero to display the desired 4mA reading.

The Span and Zero point should be checked and, if necessary, fine tuned by readjusting the Span and then the Zero.

## **Example**

It is required to set the instrument to read between 400 (4mA) and 1200 (20mA).

1. Adjust Zero control to read 0.
2. Adjust Span to read 800.
3. Adjust Zero control to read 400.

## 8 Setting the Span & Zero

### 3.1 TRAILING ZERO

A trailing zero can be added by switching S4 to the "off" position.

### 3.2 DECIMAL POINTS

The decimal point position can be set using S1 to S3 as follows:

	<b>S1</b>	<b>S2</b>	<b>S3</b>
1234	on	on	on
123.4	off	on	on
12.34	on	off	on
1.234	on	on	off

# 4. INSTALLATION

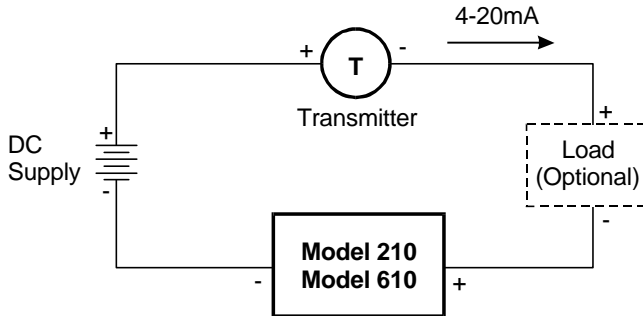

When connecting these instruments it is good practice to use shielded cable. The shield should be connected to earth near the instrument. The other end of the shield should not be connected.

Providing these wiring practices are used, these instruments comply with the requirements for Electromagnetic Compatibility as per EMC-Directive 89/336/EEC of the Council of the European Community and the following standards:

*Generic Emission Standard EN 50081-1*

Residential, Commercial & Light Industry Environment.

*Generic Emission Standard EN 50081-2*

Industrial Environment.

*Generic Immunity Standard EN 50082-1*

Residential, Commercial & Light Industry Environment.

*Generic Immunity Standard EN 50082-2*

Industrial Environment.

For CE Compliance, the Model 610 must be mounted on an earthed metal surface.

# 5. MODEL 210 MECHANICAL DETAILS

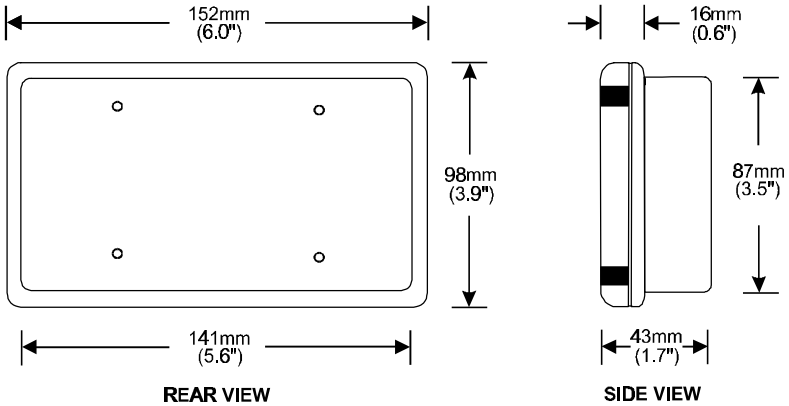

**Model 210**  
**Dimensions in millimetres and (inches)**

## 5.1 WALL MOUNTING

A wall mounting bracket is supplied with each instrument. The bracket should be attached to the wall using round head screws (do not use counter sunk screws). The bracket is mounted with the "tray" section at the bottom. The instrument is then attached to the bracket at the bottom with two screws (see diagram below).

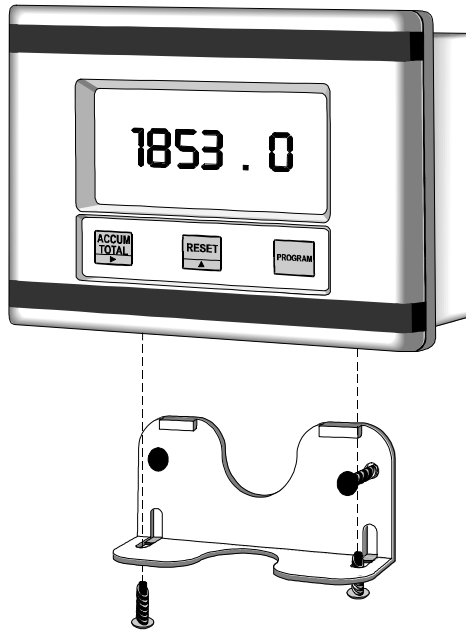

## 12 Model 210 Mechanical Details

### 5.2 REMOVING THE FRONT PANEL

The front of the instrument is removed as follows:

1. Remove both the top and bottom cover strips (ie. the dark plastic strips on the front) by levering a screwdriver under one end.
2. Undo the seven screws retaining the front. *Note that the screws should not be removed from the front panel as they are retained by O-rings.*
3. Pull the front panel free from the housing.

Replacing the front panel of the instrument is the reverse procedure.

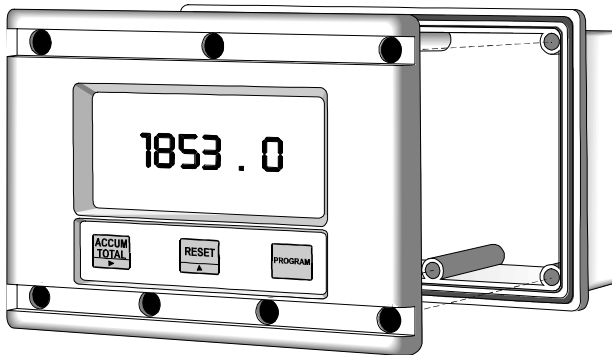
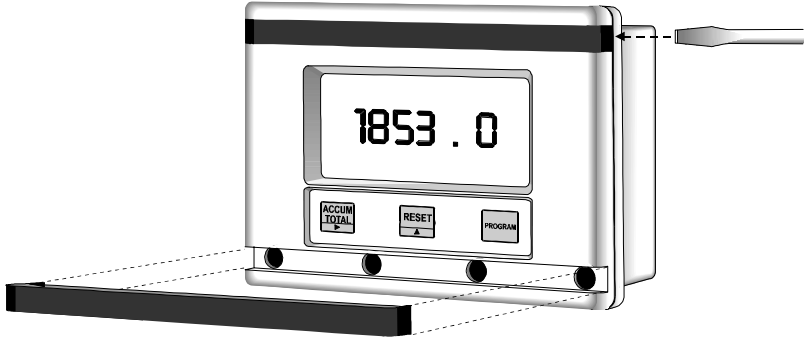

# 6. MODEL 610 MECHANICAL DETAILS

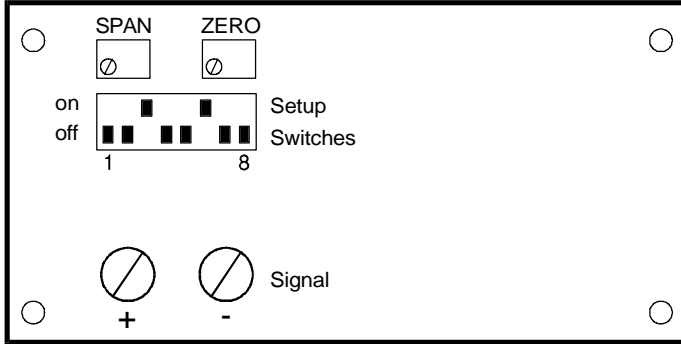

Rear View of the Model 610 Indicator

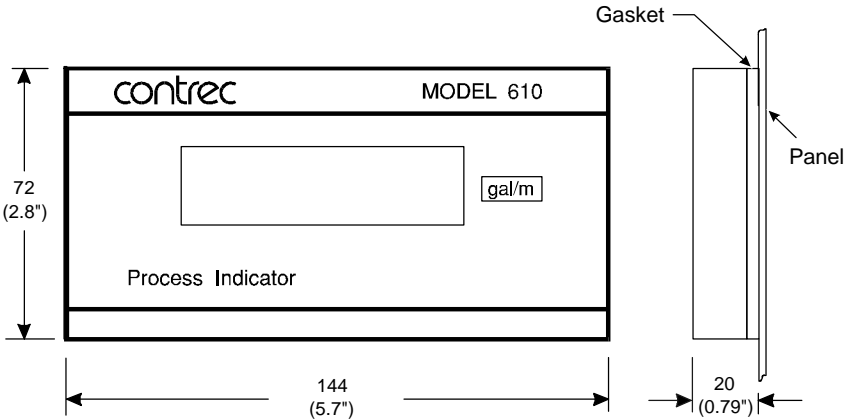

Front View of the Model 610  
Dimensions in millimetres and (inches)

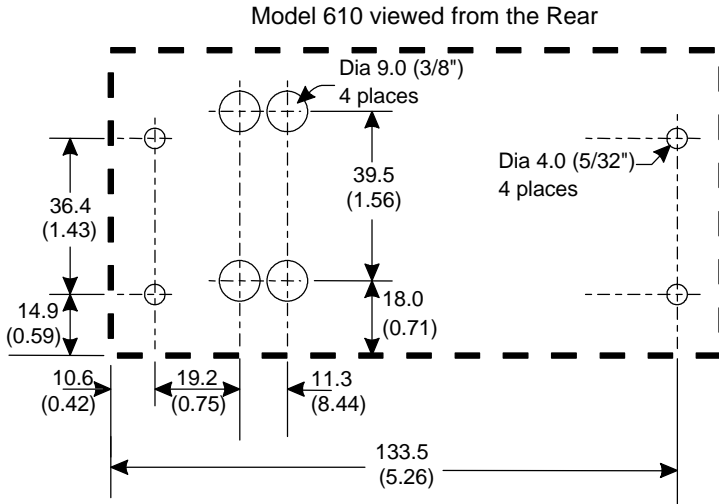

**Drilling Details**  
**Dimensions in millimetres and (inches)**