

**FLOW COMPUTER  
MODEL 405A**

CE

March 1996



# CONTENTS

<b>1. Introduction</b>	<b>3</b>
1.1 Model Number Designation	4
<b>2. Specification</b>	<b>5</b>
<b>3. Operation</b>	<b>7</b>
3.1 Front Panel Operation	8
3.2 Calculation of Rate and Total	9
3.2.1 Analog Input	9
3.2.2 The Cutoff Point	10
3.2.3 Filtering	11
3.3 Total Conversion	13
3.4 The Output Pulse	14
<b>4. Options</b>	<b>16</b>
4.1 The 4-20mA Output Option	16
4.1.1 Load Specification	17
4.1.2 Calculation	17
4.2 The RS232/422/485 Interface Option	20
4.2.1 Hardware	20
4.2.2 Multipoint Communication	21
4.2.3 Communication Protocol	23
4.3 The Relay Output Option	25
<b>5. Calibration</b>	<b>26</b>
5.1 Programming the Setup Parameters	28
5.2 Programming Options	30
5.3 Checking the Input Signal	33

<b>6. Input Circuits</b>	34
6.1 The Signal Input	34
6.2 Remote Switch Inputs	36
<b>7. Installation</b>	37
7.1 General	37
7.2 Wiring Designations for the Model 405A	39
<b>8. Trouble Shooting</b>	40
8.1 Error Codes	40
<b>Index</b>	41

# 1. INTRODUCTION

The Flow Computer Model 405A is a microprocessor based instrument designed to measure 4-20mA, 0-20mA, 1-5 Volt or 0-10 Volt signals from flowmeters and pressure transducers. The instrument can be programmed to display directly in engineering units and includes such features as linear or square law calculation, integration and digital filtering. For open channel flowmetering, the power of the input relationship is fully programmable.

Rate, Total and Accumulated Total can be displayed in engineering units on the large LCD display. A front panel membrane switch selects the function for display and a Reset button allows the Total to be reset to zero. LED's on the front panel indicate which function is displayed.

The instrument is fully programmable, with all calculation constants set via the front panel switches and stored in a non-volatile memory which will retain data indefinitely. The user can program span, zero, filtering levels, display resolution and cutoff points.

The 4-20mA, 0-20mA, 1-5 Volt and 0-10 volt input signals are isolated from the supply rails and outputs, and may therefore float independently. This ensures that the input will be compatible with all transmitters and can be used in current loops which have more than one receiver.

This instrument conforms to the EMC-Directive of the Council of European Communities 89/336/EEC and the following standards:

*Generic Emission Standard EN 50081-1* Residential, Commercial & Light Industry Environment.

*Generic Emission Standard EN 50081-2* Industrial Environment.

*Generic Immunity Standard EN 50082-1* Residential, Commercial & Light Industry Environment.

*Generic Immunity Standard EN 50082-2* Industrial Environment.

In order to comply with these standards, the wiring instructions in Section 7.1 must be followed.

## 4 Introduction

### 1.1 MODEL NUMBER DESIGNATION

The Model number of an instrument describes which input and output options are installed and the AC mains voltage rating.

#### Model 405 A. 1 0 E B

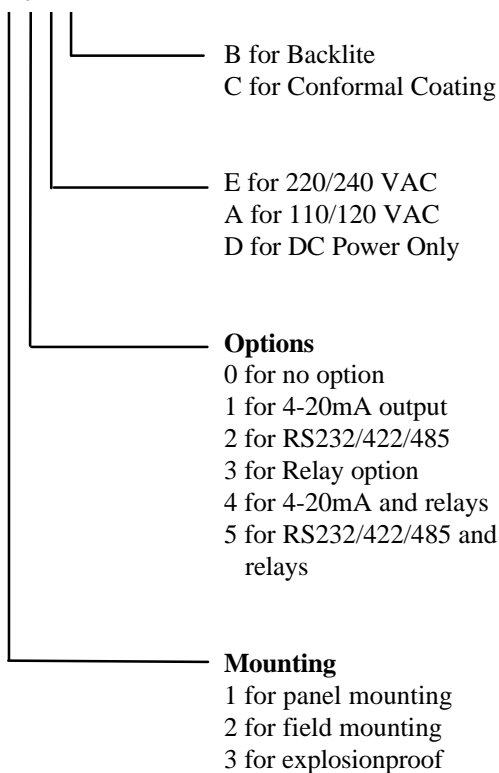

The Model number of the instrument is displayed on first entering the Calibration Mode (see Section 5).

## 2. SPECIFICATION

### *General*

Display:	6 digit LCD. 0.7" (17.8mm) high digits.
Display Update Rate:	0.25 seconds.
Transducer Supply:	8-24VDC field adjustable. 50mA maximum.
Power Requirements:	11.5 to 28.5 volts DC. 60mA typical current (no options). AC Mains: Set internally to 95 - 135 VAC or 190 - 260 VAC.
Operating Temperature:	0 to 55°C standard.
Dimensions:	5.7" (144mm) wide x 2.8" (72mm) high x 7.0" (178mm) deep.
Cutout:	5.5" (139mm) wide x 2.6" (67mm) high.

### *Analog Input*

Input:	4-20mA, 0-20mA, 1-5 Volt or 0-10 Volt. The input circuit is floating and isolated from the power supply and outputs.
Span:	0.1000 to 50000.0000.
Zero:	0.0000 to 50000.0000.
Accuracy:	0.075% of full scale.
Self-Calibrating:	An internal reference is sampled every 10 minutes. Temp Coefficient is 40 ppm/C. Aging is 20ppm/1000 Hrs.
Integration:	The rate is integrated with a timebase selectable to be in days, hours, minutes or seconds.
Cutoff:	A cutoff point can be set below which the rate is not integrated.

## 6 Specification

### *Relay Outputs*

Maximum Switching Power: 1250VA.  
Maximum Switching Voltage: 250VAC, 30VDC.  
Maximum Switching Current: 5 Amps.

### *4-20mA Output*

Resolution: 10 bits.  
Accuracy: Better than 0.05%.  
Maximum Load: 500 ohms internally powered.  
950 ohms from 24VDC.  
Isolation: Output is isolated.

### *Pulse Output*

Pulse Width: 10mSec (negative going pulse).  
Maximum Duty Cycle: 49 pulses per second.  
Output: An open collector transistor will sink  
100mA.  
Scaling: The pulse output is scaled and outputs one  
pulse each time the accumulated total  
increments.

### 3. OPERATION

The Model 405A uses a low power CMOS microprocessor to perform all control functions and calculations.

The instrument is fully programmable with all operating parameters and calculation constants user programmable. (See Section 5 entitled "Calibration" for information on programming.) All parameters and constants are stored in a non-volatile memory which retains data without battery backup for a minimum of 10 years.

A block diagram of the instrument is shown below.

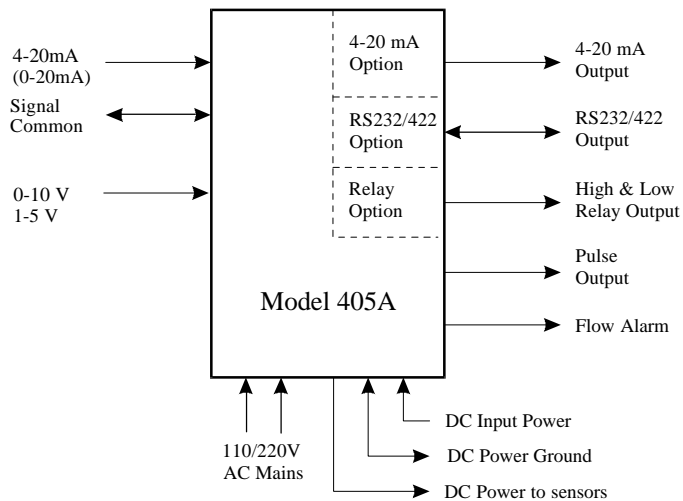

## **8 Operation**

### **3.1 FRONT PANEL OPERATION**

The display will normally show the Rate or resettable Total, as selected by the RATE or TOTAL keys on the front facia. An LED in the key panel will light to indicate which function is currently displayed.

The DISPLAY key can be used to display the Accumulated Total. On the first press of the DISPLAY key, the display shows ACCTOT for one second followed by the actual total. The Accumulated Total continuously totalises the flow and is not resettable from the front panel.

On reaching the maximum displayed total, all totals will roll over to zero and continue totalising. If, at any time, power is lost or the instrument is switched off, the totals will be stored in the non-volatile memory. When power is switched back on to the instrument, the stored totals will be recalled from memory and the totals will be incremented from the last values.

## 3.2 CALCULATION OF RATE AND TOTAL

### 3.2.1 Analog Input

The flowrate, R, is calculated as follows:

$$R = SA + C \quad \text{if the linear relationship is selected.}$$

$$R = S\sqrt{A} + C \quad \text{if a square law relationship is selected.}$$

or  $R = SA^n + C \quad \text{if an open channel relationship is selected.}$

where A = the input value.

S = the span.

C = the zero.

n = a variable power which can be programmed between 0 and 9.999.

At the minimum input (ie. 4mA, 0mA, 1 Volt or 0 Volts), A = 0, and at the maximum input (ie. 20mA, 5 Volts or 10 Volts), A = 1.

The Span, S, can be set during calibration anywhere in the range of 0.1000 to 50000.0000 and the Zero value C, set in the range 0.0000 to 50000.0000.

The Span, S, can be selected to display rate in any units desired, such as litres/minute or kilograms/hour. This also means that the Total will be displayed with the same unit of volume, ie. litres or kilograms.

Note that when the input signal drops below 3.5mA (4-20mA input) or 0.875V (1-5V input), a signal error will occur. The instrument will beep and the display will alternate between the current total and the word "SIGNAL".

## 10 Operation

### 3.2.2 The Cutoff Point

Because many transducers do not always exactly transmit 4mA (0mA, 1 Volt or 0V) when they are at zero rate, it is often necessary to define a rate below which no integration takes place. This is termed the cutoff point and is programmed as a percentage of the Span, S.

For example, if  $S = 2200$  kg/min with an offset of 100 kg/min in a square law system, and the cutoff point is set at 20.0%, the actual cutoff rate  $R_c$  can be determined as follows:

The cutoff rate is defined as:

$$R_c = 2200\sqrt{A} + 100$$

At 20% cutoff,

$$\begin{aligned} R_c &= 2200 \times 0.2 + 100 \\ &= 540 \text{ kg/min} \end{aligned}$$

The value of A which would produce this cutoff is:

$$A = 0.04 \quad (\text{since } \sqrt{0.04} = 0.2)$$

and the input signal would be:

$$\begin{aligned} I &= 16mA \times 0.04 + 4mA \\ &= 4.64mA \end{aligned}$$

Note that integration will not occur if  $A=0$  (ie. 4mA, 0mA, 1 Volt or 0 Volts), even with an offset programmed.

### 3.2.3 Filtering

Frequency fluctuations caused by pulsating flow through a flowmeter, often makes the Rate impossible to read with any precision.

The Flow Computer has a digital filter which will average out these fluctuations and enable the Rate to be read to four digit accuracy. The degree of filtering is fully programmable which means that highly accurate and stable readings can be obtained without excessive lag.

When the Rate is retransmitted via the 4-20mA output, the filtering will also average out any fluctuations on the output.

The diagram below shows a pulsating signal input together with the effect of filtering.

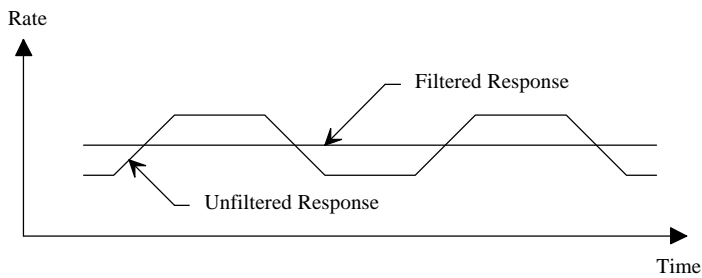

As a guideline to the degree of filtering to be used, the following table shows the response to a step change in input. The value, A, is the filter constant which is programmed during the Calibration routine. The times for the display value to reach 90% and 99% of full swing are given in seconds, for different values of A.

## 12 Operation

A	90%	99%
1	0	0
2	1	2
4	2	4
6	3	6
10	5	11
15	8	17
20	11	22
25	14	28
35	20	40
45	25	51
60	34	69
75	43	86
90	52	103
99	57	113

Table 1 - Response to a step Input (in seconds).

Note that if A is set to 1 there is no filtering of the input signal.

### 3.3 TOTAL CONVERSION

The Total Conversion feature enables the rate to be displayed in one engineering unit (eg. gallons/minute) and the totals to be displayed in another engineering unit (eg. barrels).

The Scaling Factor is always programmed in the unit relating to Rate, and the Total Conversion constant is a division factor which can be used to convert the totals to the different unit. The Total Conversion factor affects the net, accumulated and gross totals, and is limited between 0.01 and 2000.

#### For Example.

If the Rate is required in gallons per minute:

1. The Scaling Factor would be programmed as pulses per gallon
2. The timebase would be programmed as minutes

If the Totals are required in barrels:

3. The Total Conversion factor is programmed as 42 (there are 42 gallons in a barrel). All totals will now totalise in barrels.

Some common units are given below together with the Total Conversion constant (TOTCON) which should be programmed.

<u>Rate*</u>	<u>Totals</u>	<u>TOTCON</u>
Gallons (US)/	Barrels (oil)	42.000
Litres/	Kilolitres	1000
ml/	Litres	1000
Mgallons/	Acre-feet	0.32587

\* Units per second, minute, hour or day. The timebase is programmed separately during Calibration.

### 3.4 THE OUTPUT PULSE

An **OUTPUT PULSE** is available on terminal 10 for driving remote counters and produces a pulse each time the Accumulated Total increments by one digit. For example, if the Accumulated Total has a resolution of 0.01 gallons, a pulse is produced each 0.01 gallons.

The pulse is a current sinking pulse of approximately 10mSec produced by an open collector transistor and can sink up to 100mA. The maximum pulse rate is limited to 49 pulses per second and the resolution on the accumulated total must be set so that the accumulated total increments at less than 49 counts per second.

Note that due to the uneven pulse output spacing on this output, the pulse output cannot be used to drive rate indicators.

Connection of Output Pulse is as follows:

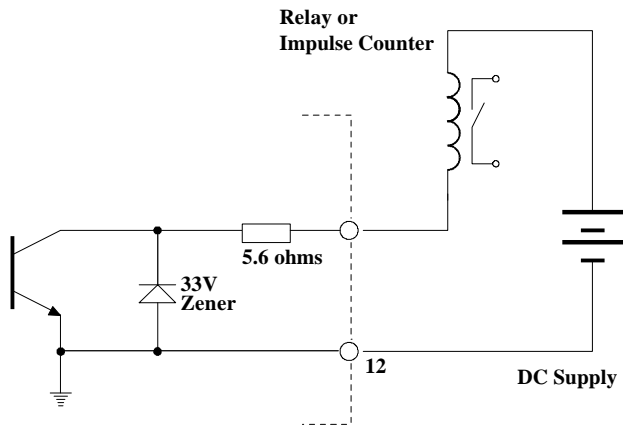

**Driving an External Relay or Impulse Counter**

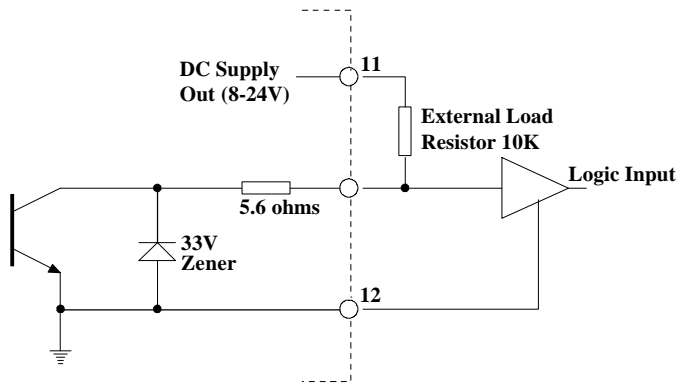

**Driving a Logic Input such as a PLC or Electronic Counter**

# 4. OPTIONS

## 4.1 THE 4-20mA OUTPUT OPTION

The 4-20mA output option provides an analog output of rate as either a 4-20mA current or a 0-10 Volt level. All output signals are electrically isolated from the instrument power supply and signal inputs to ensure minimum interference. The 4-20mA is directly proportional to the displayed rate.

Either 2 wire current transmission is available with the loop powered internally, or 3 wire transmission from an external loop supply.

A block diagram of the output is shown below and various methods of interconnection are outlined on the following pages.

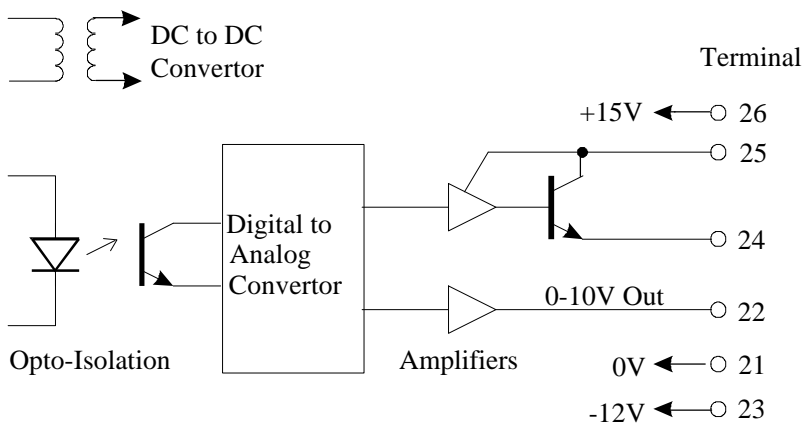

### 4.1.1 Load Specification

Maximum load which the output can drive:

Internally powered loop: 500 ohms  
 Externally powered:  $R = (V-5)/.02$   
 where V is the external loop voltage  
 R is the maximum load in ohms.

Output impedance of 0-10 Volt source: 100 ohms

### 4.1.2 Calculation

Parameters relating to this option are programmed when calibrating the instrument (see section 5) and provide for:

- Defining the rate which is equivalent to 4mA or 0 volts.
- Defining the rate which is equivalent to 20mA or 10 volts.
- Selecting the output range as 4-20mA (which also gives 2-10 volts on the voltage output circuit) or as 0-10 volts (which gives 0-20mA on the current output circuit).

By being independently able to set the output range, the instrument can effectively be programmed to amplify the input signal. In driving chart recorders, for example, this enables the output to zoom in on a particular operating area, instead of having to display the full operating range of the transducer.

For example, 4mA may be set as 0 litres/min and 20mA as 100/litres. However, the user could set 4mA as representing 100 litres/min and 20mA as representing 120 litres/min.

For rates or displayed values above and below the maximum and minimum values the output will remain at its 20mA or 4mA level respectively.

It should be noted that the output will be updated every 0.25 seconds in unison with the display and, between updates, the output value is constant .

## 18 Options

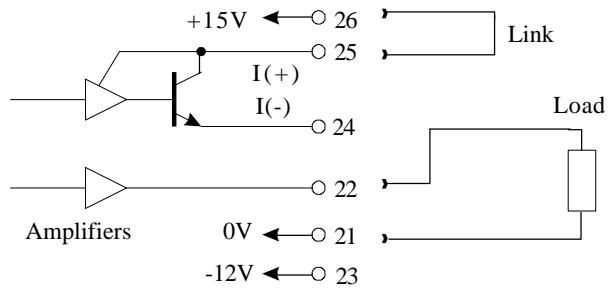

### Voltage Output Configurations

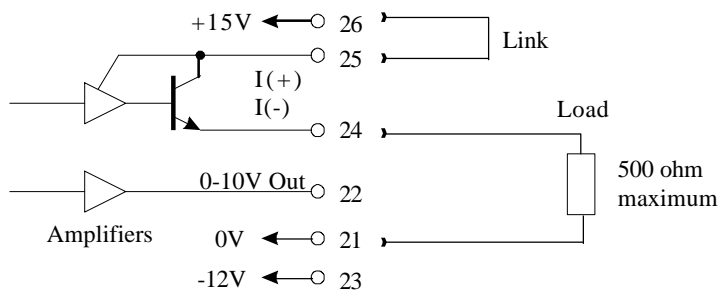

### Two Wire Transmission (Internal Supply)

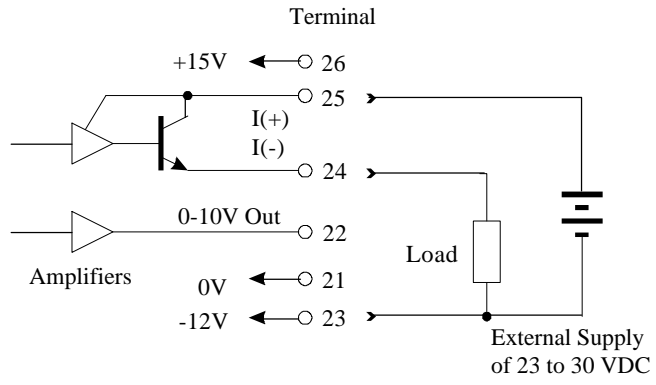

### Three Wire Transmission (External Supply)

## 4.2 THE RS232/422/485 INTERFACE OPTION

With this option installed, the circuits for both the RS232 and RS422/485 are provided as standard. They can be used to interface to both printers and computers, and a number of standard protocols are built into the instrument.

### 4.2.1 Hardware

The following diagram provides an overview of the RS232/RS422/RS485 communications hardware. All three interfaces are available on the rear terminal strips and the user can select either one by making the appropriate connections.

The RS232 interface is primarily used with printers or for simple communication with a computer over a short distance. The RS422 and RS485 interfaces are used for communication over a long distance or in applications requiring multipoint communication.

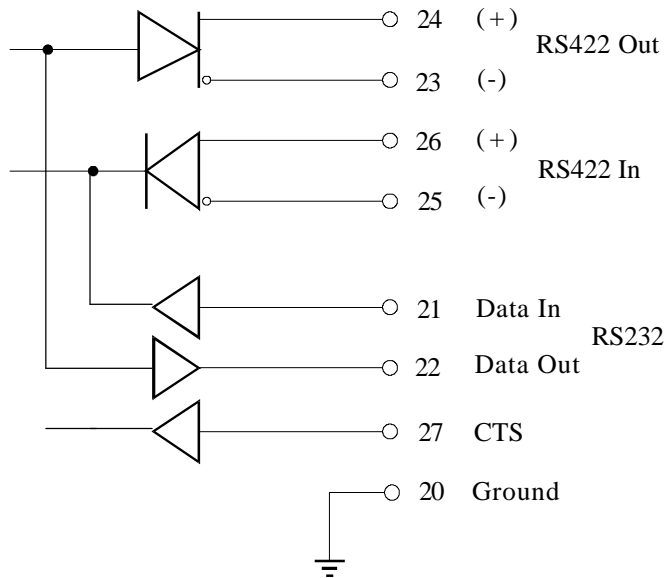

### 4.2.2 Multipoint Communication

Multipoint Communication is a system whereby a number of instruments can be addressed over a dual twisted pair interface. Up to 32 instruments can be connected to a common bus using the RS422 and RS485 interfaces as shown below.

To convert the RS422 interface to an RS485 interface, the RS422 (-) Data In Terminal must be connected to the RS422 (-) Data Out Terminal and the RS422 (+) Data In Terminal must be connected to the RS422 (+) Data Out Terminal. These connections will convert the RS422 4 wire interface to the RS485 2 wire interface, as shown in figure 2.

Each instrument can be programmed with a unique address which is used by the Master Controller (ie. IBM/PC) to identify each instrument. The Controller will send the address down the line and will alert the relevant instrument. Subsequent software protocol will control the flow of data between the Controller and the Instrument.

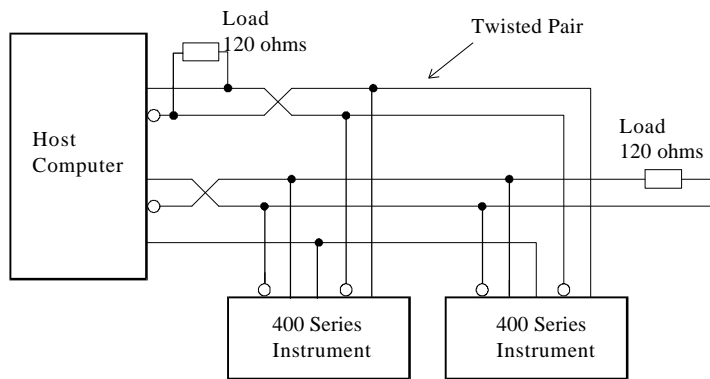

*Figure 1 RS422 Interface*

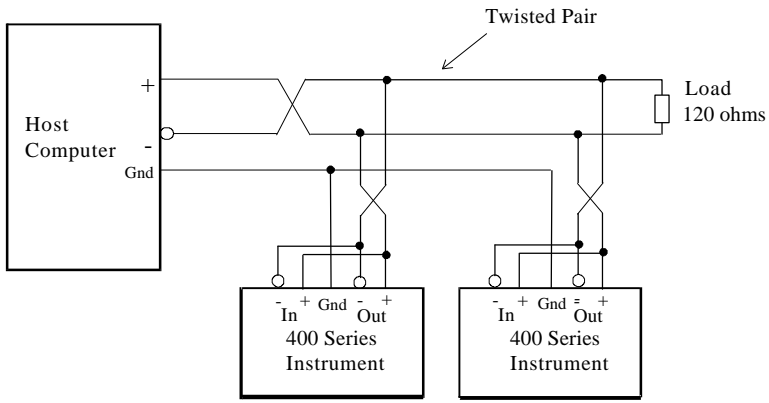

*Figure 2 RS485 Interface*

### 4.2.3 Communication Protocol

The RS232/422/485 option has a real time clock and enables the time and date to be set and printed on tickets. The date format can be European (days/months/years) or USA (months/days/years), while the time is on a 24 hour clock.

Note that the clock will only retain its time for 3 days minimum if there is no power connected to the instrument. After this period, the clock may need to be reset.

The baudrate, parity and word length can be programmed during calibration and the user must ensure that these correspond to the setting on the printer or computer with which the 405 is communicating.

The software protocols can be selected during Calibration to provide standard interfaces to a number of printers and computers. Since other interfaces will continue to be added, the user should consult the manual "*The RS232/422/485 Communications Option for the 400 Series, Version 2*", for the latest protocols and printer drivers.

#### **Printer**

A ticket is printed each time the RESET key is pressed. The instrument prints the ticket before resetting the resettable total. Protocols are provided to drive the following printers:

- 1 Standard Computer Printer (Note that the printer must have an RS232 Serial Interface).
- 2 EPSON CTM290 Slip Printer.
- 3 Model 624 Roll Printer.
- 4 EPSON TM290-2 Slip Printer.
- 5 Contrec Model 632-2 Printer.
- 6 Syntest SP-210 Printer.

The tickets can also be printed with a number of different units, including litres and gallons. The units are selectable from a pre-programmed list.

## 24 Options

A CTS input is provided, and will prevent the instrument from transmitting any further characters to a printer if the printer buffer is full. The CTS input is usually connected to the "Data Buffer Full" output from the printer.

If the printer buffer is large enough to handle the message output from the instrument, then this input need not be used and should be left unconnected.

### *Computer*

The instrument receives and transmits messages in ASCII, with all command strings to the instrument terminated by a carriage return. While replies from the instrument are terminated with a carriage return and a line feed.

Xon/Xoff protocol is also supported, and the instrument will automatically determine if the message sent by the host computer is preceded by an Xoff character. If it does recognise an Xoff as the first character of a command string, the instrument will automatically switch to Xoff/Xon protocol, and begin & end all messages with Xoff and Xon characters respectively. Xoff/Xon protocol is only available when the RS232 interface is selected.

During Calibration, the instrument can be programmed to operate in a full duplex or half duplex transmission mode. In full duplex mode, all commands sent to the instrument will be echoed back to the host computer. In half duplex, the commands are not echoed.

For more information on the computer interface please consult the manual "*The RS232/422/485 Communications Option for the 400 Series, Version 2*".

### 4.3 THE RELAY OUTPUT OPTION

The Relay output option consists of two Form C relays which can be preset during calibration to energise when the rate or displayed value exceeds or drops below the preset values.

The "low" relay is energised whenever the rate is below the preset value, and the "high" relay is energised whenever the rate exceeds the preset value. The preset values are programmed during calibration as described in section 5.

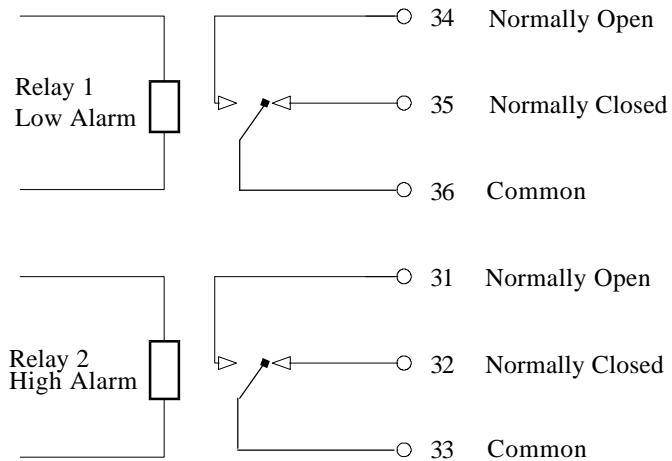

## 5. CALIBRATION

The Calibration routine enables the Setup Parameters to be programmed, as well as enabling the input signals to be checked.

The calibration routine can be entered in two ways:

- 1 By connecting a wire link (or switch) to the rear terminal strip across terminals 1 and 2 or,
- 2 By pressing the TOTAL key and, while still holding, pressing the RESET key. Both keys must then be held for approximately 6 seconds. This second method of access can be disabled during the calibration so that it is only possible to enter the calibration routine via the link across terminals 1 and 2.

The key switch actions are as follows:

<b>RATE</b>	will change a flashing digit, to the next digit.
<b>TOTAL</b>	will increment a flashing digit or change a parameter selection.
<b>RESET</b>	will reset a flashing digit to zero.
<b>DISPLAY (Program)</b>	will step through the program sequences.

Note that the arrows in the Rate and Total key switches indicate that these switches can be used to change and increment digits respectively.

In stepping through the program sequence, the Parameter Description is always displayed first, followed by the actual value or parameter. When a value or parameter can be changed, it is always shown as flashing, and the LED's in the switch panels are lit if that key switch can be used to change a value.

On first entering the Calibration routine, the display will show the Model number followed by:

<b>CAL</b>	Setup Program parameters.
<b>Options</b>	Options (if installed).
<b>Test</b>	Check Input Signals.
<b>End</b>	Exit to Normal Operation.

The user can toggle between these modes using the TOTAL switch and by using the DISPLAY switch, select the appropriate mode.

To exit Calibration, step through the Setup program or Test program until the end, and press the DISPLAY switch when **End** is displayed, (ensure the calibration link is removed).

## 5.1 PROGRAMMING THE SETUP PARAMETERS

<i>Step</i>	<i>Display</i>	<i>Description</i>	<i>Text Ref</i>
1	<b>CAL</b>	Select the Calibrate mode to setup program parameters.	
	<b>OPTIONS</b>	Options (if installed)	5.2
	<b>TEST</b>	Select the test mode to check input signals.	5.3
	<b>END</b>	Exit to normal operation.	
<i>The following steps are displayed if <b>CAL</b> is selected.</i>			
2	<b>RESTOT</b>	Reset all <u>totals</u> to zero.	
	<b>xxxxxx</b>	To clear all totals (resettable total and accumulated) press the reset key.	
3	<b>INPUT</b>	Select Input	
	<b>4-20</b>	for 4-20mA.	
	<b>0-20</b>	for 0-20mA.	
	<b>1-5</b>	for 1-5 V.	
	<b>0-10</b>	for 0-10 V.	
4	<b>SPAN</b>	The Span.	3.3.1
	<b>xxx.xx</b>	Enter the span.	
5	<b>R.BASE</b>	The Zero value.	
	<b>xxx</b>	(normally 0 for most flow measurement.)	
6	<b>PO. n</b>	The power of A <sup>n</sup> .	
	<b>Lin</b>	Select for linear input (n=1).	
	<b>Sq. Rt.</b>	Select for square law (n=½).	
	<b>Op.Ch</b>	Select for open channel.	
<i>If Open Channel is selected steps 7 &amp; 8 are displayed, otherwise the program goes to Step 9.</i>			
7	<b>POL</b>	Polarity.	
	<b>Pos</b>	Flow increases with input.	
	<b>Neg</b>	Flow decreases with input.	
8	<b>N</b>	Value of exponent n.	
	<b>x.xxx</b>	Program between 0 and 9.999.	

<i>Step</i>	<i>Display</i>	<i>Description</i>	<i>Text Ref</i>
9	<b>CUTOFF</b> <i>xx.x</i>	The signal Cutoff. Enter as a % of Span.	3.3.2
10	<b>F dPt</b>	Number of decimal points with which the <u>Rate</u> is to be displayed between 0 to 0.00000.	
11	<b>t.base</b>  <i>60secs</i> <i>hours</i> <i>days</i> <i>secs</i>	The <u>Timebase</u> with which the Span is entered must be programmed as: units/min units/hour units/day units/second	3.2.1
12	<b>FILTER</b>  <i>1</i> <i>to</i> <i>99</i>	The <u>filter constant</u> for filtering the rate display and the 4-20mA output. No filtering. Very heavy filtering.	3.2.2
13	<b>TOTCON</b>  <i>1</i> <i>x.xxxx</i>	A <u>division factor</u> to convert the totals to different units from those used for rate (ie. gallons/min and barrels). Rate and totals have the same engineering units. Other factors can be programmed between 0.01 and 2000.	3.3
14	<b>t.dPt</b>	Number of decimal points with which the resettable total is displayed between 0 to 0.000.	
15	<b>A.dPt</b>	Number of decimal points with which the <u>Accumulated</u> (non resettable) total is displayed between 0 to 0.000.	
16	<b>ACCESS</b>  <i>Front</i> <i>No Acc</i>	Enable access to calibration routine via the front keyboard only. Enable access via front keyboard. Disable access via front keyboard.	

## 5.2 PROGRAMMING OPTIONS

<i>Step</i>	<i>Display</i>	<i>Description</i>	<i>Text Ref</i>
1	<b>OPTIONS</b>	Options (if installed).	
	<i>Test</i>	Check the Input Signals.	5.2
	<i>End</i>	Exit to normal operation.	
	<i>CAL</i>	Program Setup Parameters.	5.1
<i>If the 4-20mA output option is installed, the following will be displayed:</i>			
2	<b>OUTPUT</b>	Select either 4-20mA or 0-10 volt.	
	<b>4-20</b>	4-20mA (also 2-10 volts).	4.1
	<b>0-10</b>	0-10 V (also 0-20mA).	
3	<b>OP 4</b>	Flowrate at 4mA or 0 volts.	
	<b>xxxx</b>	Enter flowrate.	
4	<b>OP20</b>	Flowrate at 20mA or 10 volts.	
	<b>xxxx</b>	Enter flowrate.	
<i>If the RS232/422/485 option is installed, the following will be displayed:</i>			
5	<b>DF</b>	Date Format.	
	<b>Eur</b>	European (ie. days/months/years).	4.2
	<b>USA</b>	USA (ie. months/days/years).	
6	<b>Date</b>	Enter date as:	
	<b>xx:xx:xx</b>	Years:Months:Days.	
7	<b>HOUR</b>	Enter time as a 24 hour clock.	
	<b>xx:xx</b>	Hours:Minutes.	

<i>Step</i>	<i>Display</i>	<i>Description</i>	<i>Text Ref</i>
8	<b>BAUD</b> <b>xxx</b>	Baudrate 300, 600, 1200, 2400, 4800 and 9600 .	
9	<b>DATA</b> <b>7</b> <b>8</b>	Word length. 7 bits. 8 bits.	4.2
10	<b>PARITY</b> <b>NP</b> <b>OP</b> <b>EP</b>	Parity. No Parity. Odd Parity. Even Parity.	
11	<b>SIGNAL</b> <b>rs232</b> <b>rs422</b>	Signal Type. RS232. RS422/485.	
12	<b>ID NO</b> <b>0</b> <b>1-99</b>	Unit Identification Number. None. Id Number.	
13	<b>PTYPE</b> <b>xx</b>  <b>00</b> <b>01</b> <b>02</b> <b>03</b> <b>04</b> <b>05</b>  <b>20</b>	Printer/Computer Type.  Standard Computer Printer. EPSON CTM 290 Slip Printer. Model 624 Roll Printer. EPSON TM290-2 Slip Printer. Contrec Model 632-2 Printer. Syntest SP-210 Printer.  Computer.	

## 32 Calibration

<i>Step</i>	<i>Display</i>	<i>Description</i>	<i>Text Ref</i>
-------------	----------------	--------------------	---------------------

*If a Printer Protocol is selected, the following message is displayed:*

13	<b>UNIT xx</b>	Units of measurement printed.	
	<b>00</b>	None.	
	<b>01</b>	Litres (Ltrs).	
	<b>02</b>	Gallons (Gals).	
	<b>03</b>	Barrels (bbls).	
	<b>04</b>	Pounds (lbs).	
	<b>05</b>	Grams (gms).	
	<b>06</b>	Kilograms (kgs).	
	<b>07</b>	Tons (tons).	

*If a Computer Protocol is selected, the following message is displayed:*

13	<b>ECHO</b>	ECHO Command.	
	<b>On</b>	Echo (Full Duplex).	
	<b>Off</b>	No Echo (Half Duplex).	

*If the Relay Option is installed, the following will be displayed:*

14	<b>AL: Hi xxxxxx</b>	High Alarm switching point. The high relay will energise if the flowrate exceeds this value.	4.3
15	<b>AL: Lo xxxxxx</b>	Low Alarm switching point. The low relay will energise if the flowrate falls below this value.	

### 5.3 CHECKING THE INPUT SIGNAL

<i>Step</i>	<i>Display</i>	<i>Description</i>	<i>Text Ref</i>
1	<b>TEST</b>	Check the Input Signals.	
	<b>OPTIONS</b>	Options (if installed).	5.2
	<b>CAL</b>	Program Setup Parameters.	5.1
	<b>END</b>	Exit to normal operation.	

The following steps are displayed if **TEST** is selected.

Depending on the input selected, the input current or voltage will be displayed.

2	<b>SR x.xx</b>	Software revision number.
3	<b>4-20mA xx.xx</b>	Displayed for 1 second followed by the actual current.
	<b>0-20mA xx.xx</b>	Displayed for 1 second followed by the actual current.
	<b>1-5 Volt xx.xx</b>	Displayed for 1 second followed by the actual voltage.
	<b>0-10 Volt xx.xx</b>	Displayed for 1 second followed by the actual voltage.

*If the RS232/422/485 option is installed, the display will then show:*

4	<b>CLOC xx:xx:xx</b>	Clock. Time in Hours:Mins:Sec.
---	--------------------------	-----------------------------------

# 6. INPUT CIRCUITS

## 6.1 THE SIGNAL INPUT

The basic circuit of the input is shown below. Both the current and voltage signals are fed to a data selector but only one signal is processed, depending upon whether a current (4-20mA or 0-20mA) or a voltage (1-5 V or 0-10 V) input configuration is selected. The signal is fed to a voltage to frequency convertor and transmitted to the microprocessor via an opto-coupler.

The microprocessor uses a crystal reference to provide an accurate measurement of the incoming frequency. Once every 10 minutes a stable and accurate internal reference is sampled and used to compensate the input. This technique ensures a highly accurate measurement and makes periodic calibration unnecessary.

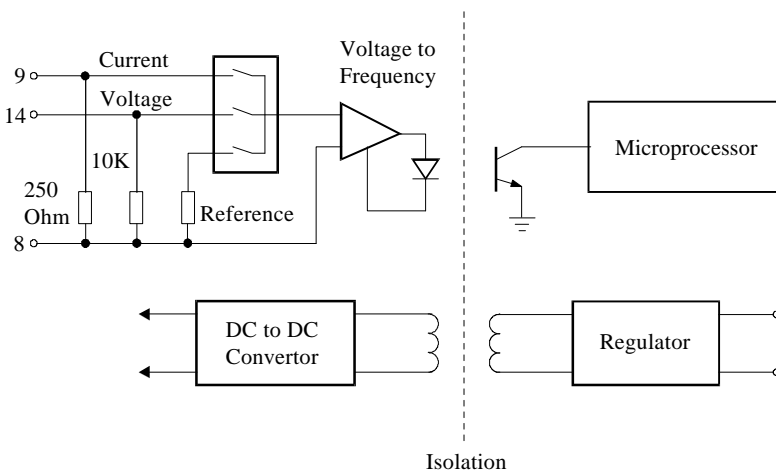

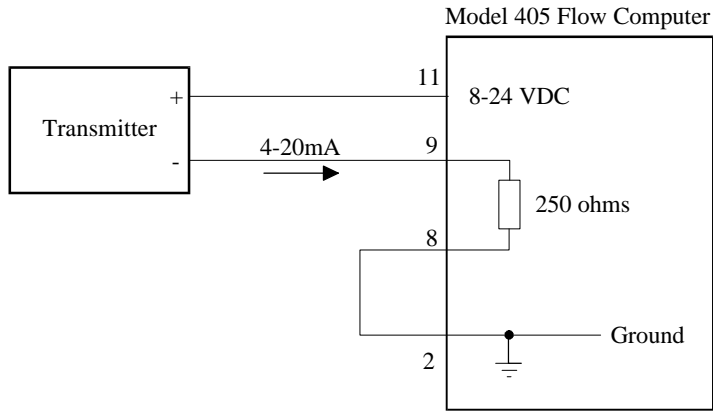

**Transmitter Powered by the Flow Computer**

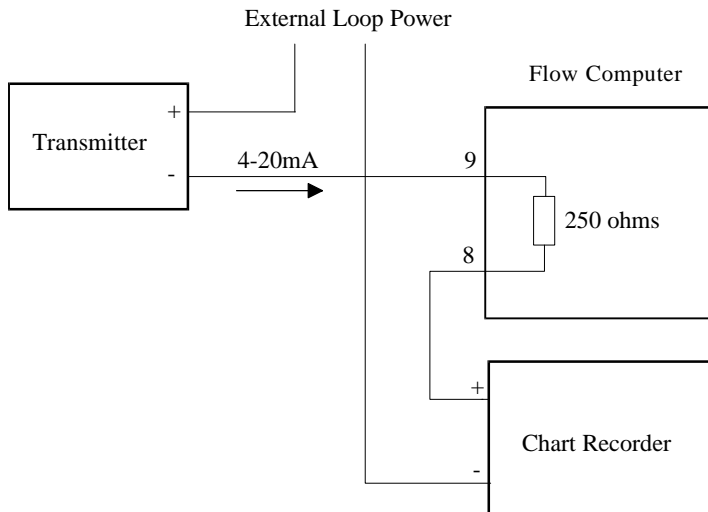

**4-20mA Loop with External Power Supply**

**INPUT CONNECTIONS**

## 6.2 REMOTE SWITCH INPUTS

Remote push-buttons can be connected to the Model 405A to duplicate the switches on the front panel.

The switches are wired as follows:

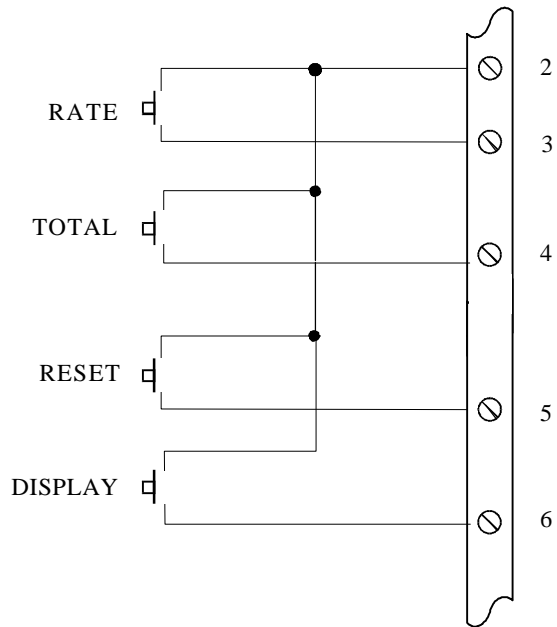

# 7. INSTALLATION

## 7.1 GENERAL

The terminal designations for the Model 405A Flow Computer are given on the following pages. The cutout hole in the panel should be 5.5" (139mm) wide x 2.6" (67mm) high. Two side clips are supplied to secure the instruments into the panel.

A case earthing point is provided via an earth lug on the side of the case. Note that this earthing point is for the case only and there is complete electrical isolation between this point and all electronic circuits. For EMC purposes, or when the instrument is connected to mains, this point must be connected to a good earth using a multi-stranded, braided wire or strap. All relay outputs are totally isolated from the case and from the internal circuitry.

A Supply Output voltage is provided to power sensors. This output will provide a regulated voltage of 8 to 24 volts and the voltage is adjustable by means of the potentiometer on the rear panel. Maximum current is 50mA and the instrument comes with the voltage factory set at 24 Volts. When the instrument is powered from a DC power source, the maximum output voltage on the Supply Output is the DC Input Voltage less 3.5 volts.

The instrument will operate from either 12 - 28 volts DC or from the mains. The mains voltage is factory set to either 95 - 135 VAC (110 VAC nominal) or 190 - 260 VAC (220 VAC nominal). An internal mains transformer provides full isolation between the mains and the electronic circuits.

The DC Ground terminal 12 provides a common ground for the 12 - 28 Volt power input, the 8 - 24 Volt output and the pulse output.

It is good practice to use shielded cables for all signal connections to the Model 405. Care must be taken to separate signal cables from power cables so as to minimise interference.

Overall shields should be connected to the case earth at the instrument end only. This connection should be as short as possible and connected to the earthing lug on the side of the case.

In order to comply with the requirements for Electromagnetic Compatibility as per EMC-Directive 89/336/EEC of the Council of European Community, this wiring practice is mandatory.

Although it is also possible to connect shields to the signal ground (terminal 2) this practice is not in accordance with EMC directives.

### ***RC Networks for Interference Suppression***

When driving highly inductive loads with the relay outputs, it is recommended that RC suppression networks (often called "Snubbers") are used for two reasons:

- To limit the amount of electrical noise caused by arcing across the contacts which may, in extreme cases, cause the microprocessor to act erratically.
- To protect the relay contacts against premature wear through pitting.

RC suppression networks consist of a capacitor and series resistor and are commonly available in the electrical industry. The values of R and C are dependant entirely on the load. However, if the user is unsure of the type of snubber to use, values of 0.25uF and 100 ohms will usually suffice. Note that only mains approved RC suppression networks should be used.

The basic principle of operation is that the capacitor prevent a series of sparks arcing across the contact as the contact breaks. The series resistor limits the current through the contact when the contact first makes.

## 7.2 WIRING DESIGNATIONS FOR THE MODEL 405A

### *Terminal Model 405A*

1	Calibration Link
2	Signal Ground
3	Rate Switch
4	Total Switch
5	Reset Switch
6	Program Switch
7	Not To Be Used
8	Flow Common (-)
9	Flow 4-20mA In (+) or 0-20mA In (+)
10	Pulse Out
11	DC Power Out (8-24 VDC)
12	DC Ground
13	DC Power Input
14	Flow 1-5 V In (+) or 0-10 V In (+)

### *Terminal Analog Flow Output RS232/422/485*

20	Not To Be Used	RS232 Signal Ground
21	0 Volts	RS232 Data in
22	0-10 Volts	RS232 Data Out
23	-12 Volts	RS422/485 (-) Data Out
24	I(-)	RS422/485 (+) Data Out
25	I(+)	RS422/485 (-) Data In
26	+15 Volts	RS422/485 (+) Data In
27	Not To Be Used	RS232 CTS

### *Terminal Relay Option*

31	Relay 2 - Normally Open
32	Relay 2 - Normally Closed
33	Relay 2 - Common
34	Relay 1 - Normally Open
35	Relay 1 - Normally Closed
36	Relay 1 - Common

# 8. TROUBLE SHOOTING

## 8.1 ERROR CODES

The instrument has extensive self test facilities and will display an error code if it detects an invalid condition. If the instrument displays an error code other than those listed below, please contact the factory.

Error codes are displayed as "Err 12" and a list of commonly encountered codes are given below:

### *Error Codes*

#### *Input Errors*

- 11 Invalid input configuration programmed.
- 14 Communications Input error (RS232/422/485 Interface).
- SIGNAL Input signal is less than 3.5mA (4-20mA) or 0.875V (1-5V).  
(See section 3.2.1.)

#### *Output Errors*

- 21 Invalid output configuration.
- 22 Communications error - Baud rate not set.
- 23 Communications error - Printer fault.

#### *Calibration Errors*

- 30 Zero Value not allowed.
- 33 Invalid Printer Type.
- 34 Invalid Volume Units selected.

# Index

4-20mA Output, 16

## A

Access, 29  
Accumulated Total, 8

## B

Baudrate, 23, 31

## C

Calibration, 26  
Chart Recorders, 17  
Clock, 23  
Communication  
  Protocol, 23  
Communications, 20  
Computer, 24  
Cutout, 5

## D

Date, 23  
Decimal Points, 29  
Dimensions, 5  
Display Key, 8

## E

Earth Lug, 37  
Earthing Point, 37  
Electrical Noise, 38  
Error Codes, 40

## F

Filtering, 11  
Front Panel, 8

## G

Ground, 37

## I

Identification  
  Number, 31  
Inductive Loads, 38  
Input Circuits, 34  
Installation, 37  
Interference, 38  
Isolation, 37

## M

Mains Voltage, 37  
Model Number, 4  
Multipoint  
  Communication, 21

## N

Non-volatile Memory, 8

## O

Operating  
  Temperature, 5  
Operation, 7  
Options, 16  
Output Pulse, 14

## P

Parity, 23, 31  
Power Requirements, 5

Printer, 23  
Pulsating Signal, 11  
Pulse Output, 14

## R

Regulated Voltage, 37  
Relay Output, 25  
Remote Push-buttons, 36  
Response, 12  
RS232/422/485  
  Interface, 20

## S

Self Test, 40  
Setup Parameters, 26  
Snubbers, 38  
Specification, 5  
Supply Output, 37

## T

Terminal, 39  
Terminal  
  Designations, 37  
Test, 33  
Tickets, 23  
Time, 23  
Timebase, 29  
Total Conversion, 13  
Transducer Supply, 5  
Trouble Shooting, 40

## W

Wiring Designations, 39  
Word Length, 23