

**FLOW COMPUTER
MODEL 405L**



December 1996

CONTENTS

1. Introduction	3
1.1 Model Number Designation.	5
2. Specification	6
3. Operation	9
3.1 Front Panel Operation	11
3.2 Single and Quadrature Inputs	13
3.3 Calculation of Rate and Total	14
3.3.1 Frequency Input	14
3.3.2 Analog Input	15
3.3.3 Filtering	16
3.4 Total Conversion	18
3.5 Non-Linearity Correction	19
3.6 The Output Pulse and Flow Alarm	21
4. Temperature Compensation	23
4.1 Temperature Input (RTD or 4-20mA)	24
4.2 Volume Correction for General Liquids	25
4.3 Density Correction for General Liquids	27
4.4 Compensation for Petroleum Liquids	29
4.5 Compensation for Liquefied Petroleum Gas (LPG)	31
4.6 Density Meter Input	32

5. Options	33
5.1 The 4-20mA Output Option	33
5.1.1 Load Specification	34
5.1.2 Calculation	34
5.2 The RS232/422/485 Interface Option	37
5.2.1 Hardware	37
5.2.2 Multipoint Communication	38
5.2.3 Communication Protocol	40
5.3 The Relay Output Option	42
6. Calibration	43
6.1 Programming the Setup Parameters	45
6.2 Programming Options	51
6.3 Checking the Input Signal	54
7. Input Circuits	56
7.1 Flow Inputs	56
7.1.1 Frequency Inputs	56
7.1.2 Analog Flow Inputs	62
7.2 Temperature or Density Input	63
8. Installation	65
8.1 General	65
8.2 Wiring Designations for the Model 405L	67
9. Trouble Shooting	68
9.1 Error Codes	68
Index	69

1. INTRODUCTION

The Model 405L Flow Computers use temperature correction to calculate the volumetric flow for liquids at standard reference conditions.

Mass flow can also be calculated from the temperature input and the volumetric flow input. Therefore, the Model 405L Flow Computer will enable relatively low cost mass flow measurement using positive displacement or turbine flowmeters and an RTD.

The Model 405L is ideally suited to custody transfer applications and includes the API/ASTM equations covering general petroleum products and LPG. Quadrature signal inputs are provided, where it is required to ensure the integrity of the flow signal, or to measure bi-directional flow.

Two versions of the instrument are available; the Model 405LR with direct RTD input and the Model 405LA with a 4-20mA temperature input.

Both offer the following temperature compensation.

1. Density Correction

A five point temperature-density curve can be programmed, and the MASS flow calculated.

2. Volume Correction for General Liquids

The thermal Coefficient of Expansion of the liquid can be programmed and a reference temperature defined for volume correction to that reference.

3. Petroleums

Volumetric correction to 15°C or 60°F for Crude, Oils, Jet Fuel and Gasoline as determined by API/ASTM Table 54A, 54B and 54D for metric units and Tables 24A, 24B and 24D for US units.

4 Introduction

4. Liquid Petroleum Gas

Volumetric correction to 15°C or 60°C for LPG as determined by Tables 54 and 34 of the API/ASTM standards.

In addition, the Model 405LA will accept a 4-20mA signal from a Density Meter and use this input to calculate mass flow.

The Model 405L Flow Computers are designed to supersede Contrec Models 405LC and 411. They are fully compatible both functionally and electronically, although the Model 405L uses 4 wire RTD measurement, in place of the 2 wire system used on the Model 411. Before using the Model 405L to replace other instrument versions, the terminal designations and DIP switch positions on the rear panel should be carefully checked, since there are some changes.

This instrument conforms to the EMC-Directive of the Council of European Communities 89/336/EEC and the following standards:

Generic Emission Standard EN 50081-1 Residential, Commercial & Light Industry Environment.

Generic Emission Standard EN 50081-2 Industrial Environment.

Generic Immunity Standard EN 50082-1 Residential, Commercial & Light Industry Environment.

Generic Immunity Standard EN 50082-2 Industrial Environment.

In order to comply with these standards, the wiring instructions in Section 8.1 must be followed.

1.1 MODEL NUMBER DESIGNATION

The Model number of an instrument describes which input and output options are installed and the AC mains voltage rating.

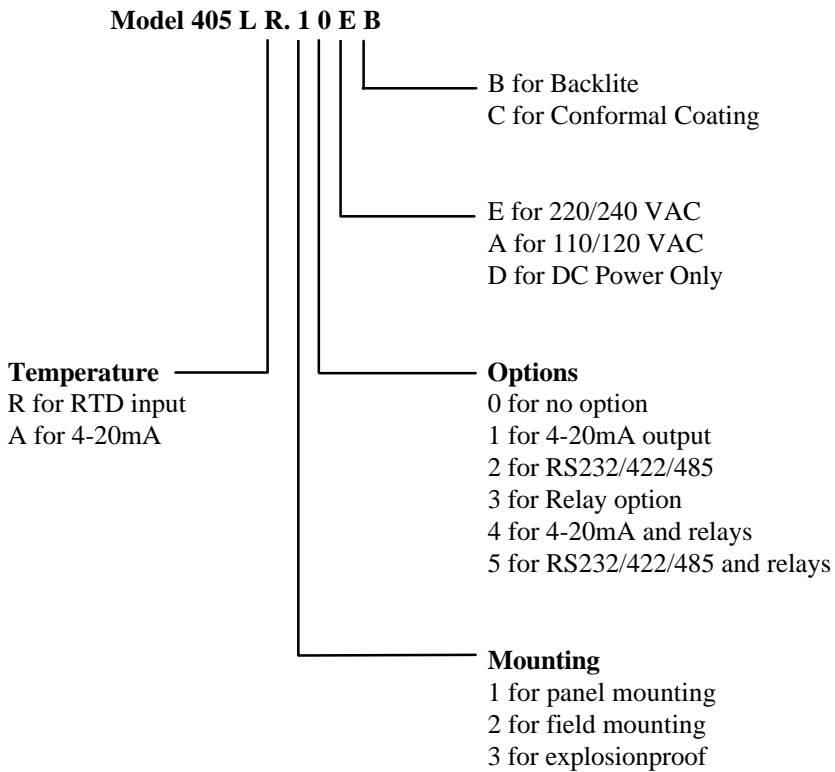

The Model number of the instrument is displayed on first entering the Calibration Mode (see Section 6).

2. SPECIFICATION

General

Display:	6 digit LCD. 0.7" (17.8mm) high digits.
Display Update Rate:	0.25 seconds.
Transducer Supply:	8-24VDC field adjustable. 50mA maximum.
Power Requirements:	11.5 to 28.5 volts DC. 60mA typical current (no options). AC Mains: Set internally to 95 - 135 VAC or 190 - 260 VAC.
Operating Temperature:	0 to 55°C standard.
Dimensions:	5.7" (144mm) wide x 2.8" (72mm) high x 7.0" (178mm) deep.
Cutout:	5.5" (139mm) wide x 2.6" (67mm) high.

Frequency Input

Frequency Range:	Minimum: 0.25Hz on Rate. 0Hz on Total.
	Maximum: 10KHz with a single input. 2.5KHz with a quadrature input.
Input Circuits:	Will accept most sine logic and proximity switch inputs (see section 7.1.1).
Scaling Range:	0.1000 to 50,000.
Non-Linear Correction:	Up to 10 correction points.

RTD Input (Model 405LR)

Temperature Measurement Range:	-100°C (-148°F) to 200°C (392°F).
Measurement Accuracy:	0.1°C
RTD Type:	Platinum PT100.
Linearity Correction:	Internally Compensated.

4-20mA Inputs

Measured: Flow, temperature or density.
Input Impedance: 250 ohms.
Measurement Accuracy: 0.05%
Isolation: Inputs are not isolated.

Relay Outputs

Maximum Switching Power: 1250VA.
Maximum Switching Voltage: 250VAC, 30VDC.
Maximum Switching Current: 5 Amps.

4-20mA Output

Resolution: 10 bits.
Accuracy: Better than 0.05%.
Maximum Load: 500 ohms internally powered.
950 ohms from 24VDC.
Isolation: Output is isolated.

Pulse Output

Pulse Width: 10mSec (negative going pulse).
Maximum Duty Cycle: 49 pulses per second.
Output: An open collector transistor will sink
100mA.
Scaling: The pulse output is scaled and outputs one
pulse each time the accumulated total
increments.

Non-linearity Correction

Number of Points: 10 correction points maximum.
Correction between points: Linear interpolation used.

8 Specification

Temperature Correction

Density Correction for
General Liquids:

A five point temperature density table can
be programmed.
Temperature Range: -273°C to 200°C.
(-459°F to 392°F).

LPG:

To API/ASTM Tables 34 and 54
Accuracy: 0.04% for metric.
0.12% for US.
Temperature Range: -45°C to 60°C.
(-49°F to 140°F).

Petroleums:

Correction to API/ASTM Tables as follows:
Crude: Tables 24A and 54A.
Gas, Jet, Oils: Tables 24B and 54B.
Lube Oil: Tables 24D and 54D.
Accuracy: 0.075%
Temperature Range: -100°C to 200°C.
(-148°F to 392°F).

Volume Correction for
General Liquids:

Correction to any base temperature using a
constant thermal co-efficient of expansion.
Accuracy: 0.05%
Temperature Range: -273°C to 200°C.
(-459°F to 392°F).

Density Meter Input

A density meter with 4-20mA output can be
connected, in place of a temperature sensor,
to provide a mass flow reading.
(Model 405LA only.)

3. OPERATION

The Model 405L uses a low power CMOS microprocessor to perform all control functions and calculations.

The instrument is fully programmable with all operating parameters and calculation constants user programmable. (See Section 6 entitled "Calibration" for information on programming.) All parameters and constants are stored in a non-volatile memory which retains data without battery backup for a minimum of 10 years.

Two versions of the instrument are available and have the following features:

Model 405LR

- ◆ Temperature Input directly from a PT100 RTD.
- ◆ Frequency Input from a single flowmeter with a single or dual frequency output.

The dual frequency unit (termed "Quadrature") is often required in custody transfer applications to ensure the integrity of the flow signal and to measure bi-directional flow.

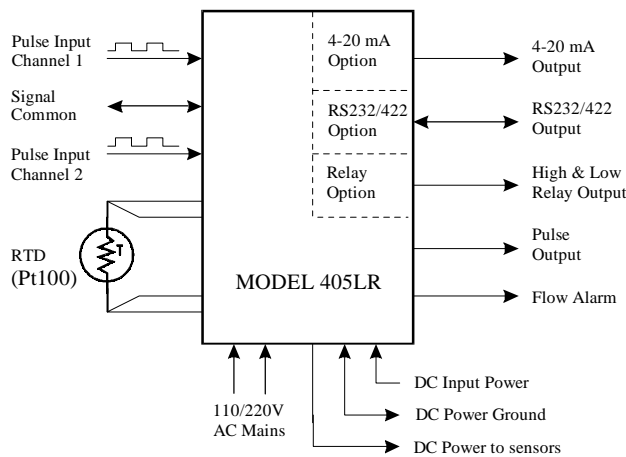

10 Operation

Model 405LA

- ◆ Temperature Input from a temperature transmitter (4-20mA).
- ◆ Either a Frequency Input (Single or Quadrature) or Analog (4-20mA) from a single flowmeter.

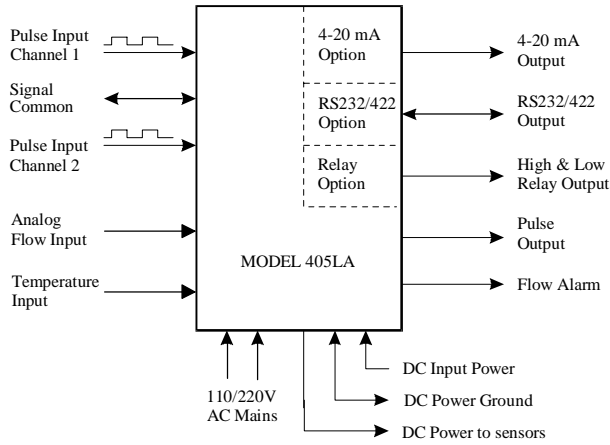

On both the Models 405LR and 405LA, a DIL switch on the rear panel enables the frequency input circuit to be set to interface with a wide range of flowmeters, including turbine flowmeters and flowmeters with Namur type sensors.

3.1 FRONT PANEL OPERATION

The display will normally show the Rate or Net Total, as selected by the RATE or TOTAL keys on the front facia. An LED in the key panel will light to indicate which function is currently displayed.

The DISPLAY key can be used to display the following additional information:

Accumulated Total

On the first press of the DISPLAY key, the display shows Acctot for one second followed by the actual total.

Temperature

If temperature compensation is selected, the second press of the DISPLAY key will show the product temperature as:

xxx.x F or xxx.x C

If a Density Meter input is selected rather than temperature, the density (and not temperature) will be displayed. The displays will read "DENS" for one second followed by the actual density value.

Gross Total

If temperature compensation is selected, the third press of the DISPLAY key will show GROSS for one second followed by the actual gross total.

If the DISPLAY key is again pressed, the display will revert to the Rate or Total display. In any display function, if the DISPLAY key has not been pressed for 5 seconds, the display will automatically go back to the Rate or Total display.

12 Operation

The display functions are defined as follows:

RATE	Rate of flow in engineering units, with temperature correction (if selected).
TOTAL	The Net resettable total. The Net Total is temperature corrected (if selected).
ACCUMULATED	The Accumulated Total is a Net Total (ie temperature compensated) but it is not resettable via the front RESET key.
GROSS TOTAL	The Gross Total is the total <u>without</u> temperature correction. The Gross Total will be reset each time the RESET key is pressed.
TEMPERATURE	The instantaneous temperature of the fluid being measured, in °C or °F depending on which units are selected when the instrument was programmed.

All values of rate and total will also be compensated for flowmeter non-linearity, if this function is selected.

On reaching the maximum displayed total, all totals will roll over to zero and continue totalising. If, at any time, power is lost or the instrument is switched off, the totals will be stored in the non-volatile memory. When power is switched back on to the instrument, the stored totals will be recalled from memory and the totals will be incremented from the last values.

3.2 SINGLE AND QUADRATURE INPUTS

In most industrial flowmetering applications, a frequency producing flowmeter has only a single output.

However, in many custody transfer applications, it is a requirement that the flowmeter has two outputs so that the integrity of the signal can be assured. This usually requires a turbine meter to have two coils, or a positive displacement meter to have two pulse units.

The Model 405L can interface to flowmeters fitted with two sensors and connections to the flowmeters are outlined in Section 7.1.1.

The quadrature input has two functions.

1 To detect a difference in the number of pulses from each input during delivery.

The instrument will alarm if the pulse difference (since reset) exceeds 1 in 1000 pulses. When an alarm condition exists the totals will cease counting and will freeze at the last total prior to the alarm.

On detection of the alarm condition, the alarm output on terminal 7 will go low (energise) and the display will cease counting. The output can be used to shutoff the flow or to warn the operator. The display will also periodically flash the error message, ERR 13.

The alarm condition is reset by pressing the DISPLAY key.

2 Bi-directional Flow.

The 405L has the ability to detect forward and reverse flow. The inputs must be connected with channel 1 being the 90° flow signal and channel 2 being the 0° signal. For forward/reverse detection to function correctly, there must be clear definition of the input signals.

14 Operation

3.3 CALCULATION OF RATE AND TOTAL

3.3.1 Frequency Input

For instruments without temperature compensation, the volumetric flowrate at flow conditions, R , is calculated as follows:

$$R = \frac{f \times H}{S}$$

- where f is the input frequency in Hz.
 H is the timebase of rate and is 1 for seconds, 60 for minutes, 3600 for hours and 86,400 for days.
 S is the Scaling Factor.

The Scaling Factor, S , is equal to the K-factor of the flowmeter expressed in pulses per unit volume.

The flowrate, R , as expressed in the above equation, is the volumetric flowrate at flow conditions. With temperature compensation, the above flowrate, R , is corrected to give the flowrate at a base temperature, or the mass flow. Temperature Correction is covered in detail in Section 4.

The user programs the Scaling Factor and selects the timebase during the Calibration procedure as detailed in Section 6 of this manual.

When non-linearity correction is programmed, up to 10 scaling factors are programmed to cover different frequency ranges. The instrument will then automatically select the correct scaling factor to be applied at the measured frequency.

3.3.2 Analog Input

On Model 405LA, where the analog input is selected rather than frequency, the flowrate at flow conditions, R , is calculated as follows:

$$R = A^n \times S$$

where A represents the input signal and is 0 at 4mA and 1 at 20mA.
 S is the Span and is the flowrate at 20mA.
 n is 1 for a linear input or $\frac{1}{2}$ for inputs from differential pressure devices.

The user programs S and n , during the Calibration procedure, as detailed in Section 6 of this manual.

Note that the Model 405L will **only handle flow signals from differential pressure type flow devices** (ie. when $n = \frac{1}{2}$), for:

1. No temperature compensation.
2. Density Correction for general liquids
3. A density meter input.

A cutoff can also be programmed for analog inputs which prevents the display of flowrate and integration of the input signal at low flowrates. The cutoff is programmed as a percentage of the Span, S .

Note that when the input signal drops below 3.5mA a signal error will occur. The instrument will beep and the display will alternate between the current total and the word "SIGNAL".

16 Operation

3.3.3 Filtering

Frequency fluctuations caused by pulsating flow through a flowmeter, often makes the Rate impossible to read with any precision.

The Flow Computer has a digital filter which will average out these fluctuations and enable the Rate to be read to four digit accuracy. The degree of filtering is fully programmable which means that highly accurate and stable readings can be obtained without excessive lag.

When the Rate is retransmitted via the 4-20mA output, the filtering will also average out any fluctuations on the output.

The diagram below shows a pulsating signal input together with the effect of filtering.

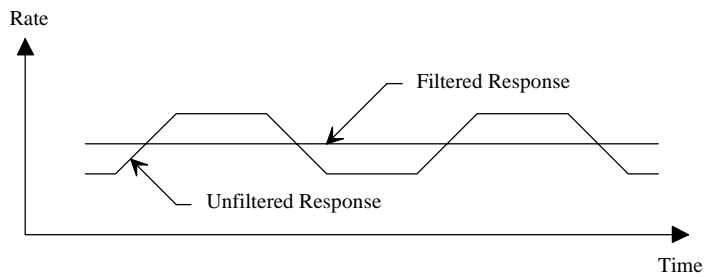

As a guideline to the degree of filtering to be used, the following table shows the response to a step change in input. The value, A, is the filter constant which is programmed during the Calibration routine. The times for the display value to reach 90% and 99% of full swing are given in seconds, for different values of A.

A	90%	99%
1	0	0
2	1	2
4	2	4
6	3	6
10	5	11
15	8	17
20	11	22
25	14	28
35	20	40
45	25	51
60	34	69
75	43	86
90	52	103
99	57	113

Table 1 - Response to a step Input (in seconds).

Note that if A is set to 1 there is no filtering of the input signal.

18 Operation

3.4 TOTAL CONVERSION

The Total Conversion feature enables the rate to be displayed in one engineering unit (eg. gallons/minute) and the totals to be displayed in another engineering unit (eg. barrels).

The Scaling Factor is always programmed in the unit relating to Rate, and the Total Conversion constant is a division factor which can be used to convert the totals to the different unit. The Total Conversion factor affects the net, accumulated and gross totals, and is limited between 0.01 and 2000.

For Example.

If the Rate is required in gallons per minute:

1. The Scaling Factor would be programmed as pulses per gallon
2. The timebase would be programmed as minutes

If the Totals are required in barrels:

3. The Total Conversion factor is programmed as 42 (there are 42 gallons in a barrel). All totals will now totalise in barrels.

Some common units are given below together with the Total Conversion constant (TOTCON) which should be programmed.

<u>Rate*</u>	<u>Totals</u>	<u>TOTCON</u>
Gallons (US)/	Barrels (oil)	42.000
Litres/	Kilolitres	1000
ml/	Litres	1000
Mgallons/	Acre-feet	0.32587

* Units per second, minute, hour or day. The timebase is programmed separately during Calibration.

3.5 NON-LINEARITY CORRECTION

Non-linearity correction enables the instrument to correct for known non-linearities in the flowmeter. This feature is not selectable for analog flow inputs.

Up to 10 frequencies and scaling factors can be programmed. Data on the flowmeter non-linearity can usually be supplied by the flowmeter manufacturer in the form of a Calibration Certificate, and is the result of individual tests on a flowmeter over a range of flowrates. The Certificate will list a number of flowrates or frequencies with the measured K-factor (eg. pulses per gallon or litre) at each flowrate.

The following diagram graphs the change in scaling factor with frequency for a hypothetical flowmeter. The heavy black line represents the actual scaling factor of the flowmeter, while the light black line is the approximation used in the instrument.

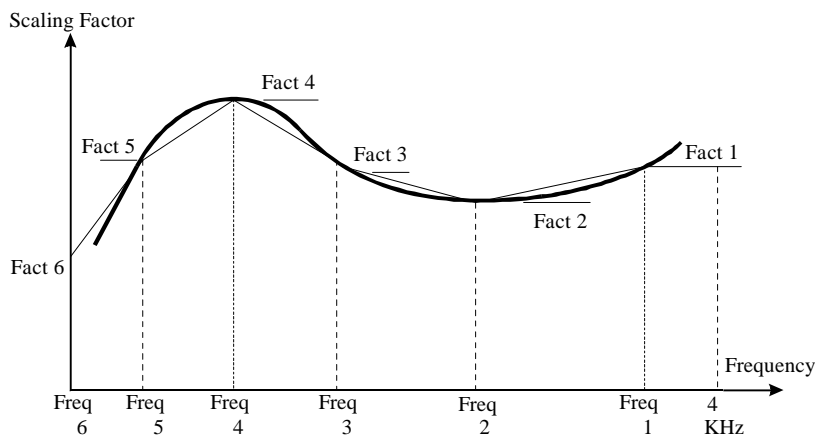

Linear Interpolation is used between points on the curve, except for Factor 1 which maintains a constant value between Frequency 1 and the maximum input frequency.

20 Operation

During Calibration, the program requires the user to input a frequency and the Scaling Factor (K-factor of the flowmeter) at up to 10 points on the curve. Generally these points will correspond to those shown on the Certificate.

If any frequency is set to 0Hz (Frequency 6 in the preceding example), then the program will require no further correction points to be programmed. Hence, the user can program any number of correction points up to a maximum of 10. Note that if all 10 correction points are required, then Frequency 10 will automatically be assigned the value of 0Hz.

3.6 THE OUTPUT PULSE AND FLOW ALARM

An **OUTPUT PULSE** is available on terminal 10 for driving remote counters and produces a pulse each time the Accumulated Total increments by one digit. For example, if the Accumulated Total has a resolution of 0.01 kilograms, a pulse is produced each 0.01 kilograms.

The pulse is a current sinking pulse of approximately 10mSec produced by an open collector transistor and can sink up to 100mA. The maximum pulse rate is limited to 49 pulses per second and the resolution on the accumulated total must be set so that the accumulated total increments at less than 49 counts per second.

Note that due to the uneven pulse output spacing on this output, the pulse output cannot be used to drive rate indicators.

The **FLOW ALARM** uses an identical circuit to the Output Pulse, and is on terminal 7.

The Flow Alarm is used by the Quadrature Input, if selected, and will output an error signal if there is a difference between the input pulses as described in Section 3.2. If an analog flow input signal is selected, the Flow Alarm output will activate if the flow signal falls below 3.5mA.

The Flow Alarm output will switch "on" (ie the signal goes low) whenever an alarm condition exists. The Alarm will switch "off" (ie the signal goes high) when the alarm is reset by pressing the DISPLAY key.

22 Operation

Connection of Output Pulse and Flow Alarm are as follows:

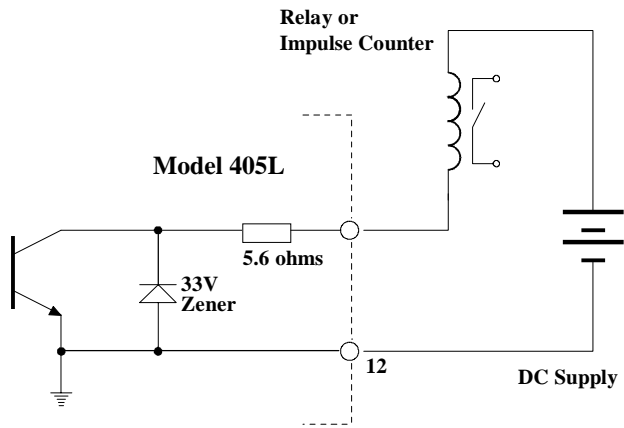

Driving an External Relay or Impulse Counter

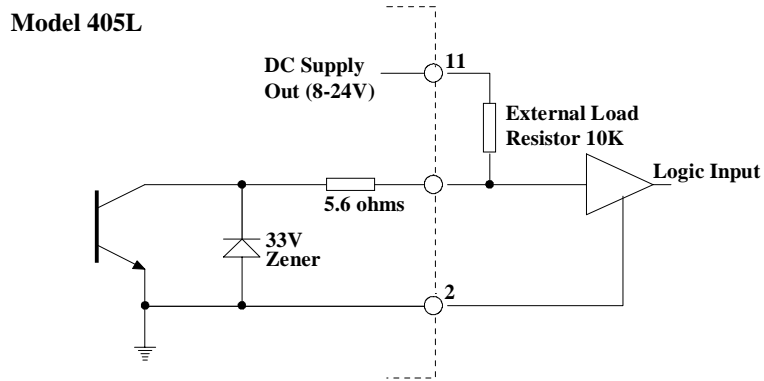

Driving a Logic Input such as a PLC or Electronic Counter

4. TEMPERATURE COMPENSATION

Temperature compensation gives the instrument the capability to correct for changes in volume of the measured liquid with temperature. There are four methods of compensation which can be selected.

1. Density correction for general liquids with known temperature density characteristics. A five point temperature-density curve can be programmed and the MASS flow calculated.
2. Volume correction for general liquids using a thermal coefficient of expansion. This method is useful for correction to a base volume over relatively small changes in temperature.
3. Correction for Petroleum Liquids to US and International standards for a wide range of petroleums, to a base temperature of 60°F/15°C.
4. Correction for LPG to US and International standards, to a base temperature of 60°F/15°C.

In addition, the Model 405LA will also accept a 4-20mA signal from a Density Meter (in place of a temperature input) and use this input to calculate MASS flow.

24 Temperature Compensation

4.1 TEMPERATURE INPUT (RTD OR 4-20mA)

The Model 405L is available with either a PT100 Platinum RTD input or with a 4-20mA input. The input option must be specified on ordering.

The temperature inputs are continually checked to ensure that they are within the specified limits and an Input Error will be displayed as "Err 12" if the 4-20mA input drops below 3.5mA or if the RTD resistance is outside the valid resistance ranges.

RTD Input

Instruments with RTD inputs are identified by the Model number **405LR**. A four wire temperature measurement is used to give high accuracy and, internally, the software will compensate for the non-linearity of the RTD. Details of the installation are given in Section 7.2.

During calibration, a "temperature adjust facility" enables the temperature reading to be adjusted. This allows for manufacturing tolerances on the RTD to be corrected.

4-20mA

A two wire 4-20mA input from a temperature transmitter or density meter can be input to instruments with the Model number designation **405LA**.

With a 4-20mA input, a linear relationship is assumed over the span of the transmitter. The temperatures or densities at 4mA and 20mA are both programmable during the Calibration routine.

4.2 VOLUME CORRECTION FOR GENERAL LIQUIDS

For general liquids, a linear correction factor can be applied, to give volumetric flow at base conditions. The flow equation is:

$$\text{Volume Corrected Flowrate} = \frac{\text{Volumetric Flowrate}}{1 + (T_f - T_b) \cdot a}$$

where T_f is the flow temperature (°C or °F).

T_b is the base temperature (°C or °F).

a is the Thermal Coefficient of Expansion per °C or °F.

The Volumetric Flowrate is the flowrate defined in sections 3.3.1 and 3.3.2

The Thermal Coefficient of Expansion, "a", for a liquid can be determined empirically or can be found in chemical engineering texts. A list of coefficients is given on the following page for a number of petroleum products at 15°C.

26 Temperature Compensation

Thermal Coefficients of Expansion at 15°C (60°F)

PRODUCTS	DENSITY AT 15°C (kg/litre)	COEFFICIENT OF EXPANSION/°C
LPG - Propane	0.510	0.00290
- Butane	0.580	0.00200
Aviation Gasoline	0.695	0.00120
Petrol	0.740	0.00110
Aviation Jet A-1	0.795	0.00094
Lighting Kerosene	0.790	0.00094
Power Kerosene	0.810	0.00087
Heating Oil	0.820	0.00087
Automotive Distillate	0.840	0.00084
Industrial Diesel Fuel	0.855	0.00082
Fuel Oil: High Sulphur	0.980	0.00070
Low Sulphur	0.900	0.00075
Bitumen	1.020	0.00063
Crude Oil (Bass Strait)	0.796	0.00087
Benzene	0.880	0.00120
Toluene	0.870	0.00110
Xylene	0.860	0.00100
White Spirit	0.780	0.00095
Mineral Turpentine	0.820	0.00087
Lube Oils		
SAE 10	0.880	0.00077
20	0.890	0.00076
30	0.890	0.00076
40	0.900	0.00074
50	0.900	0.00074
Water	1.000	0.00031

4.3 DENSITY CORRECTION FOR GENERAL LIQUIDS

If density correction for general liquids is selected, a five point temperature density table can be programmed. The instrument uses this table to determine the density of the product after measuring the temperature of the fluid.

For known fluids, the temperature-density characteristics are well documented in standard chemical reference books. One to five correction points can be programmed, and the user inputs the number of points during programming.

The instrument will also allow a constant density value to be programmed by selecting only one correction point. In this case, the temperature input is ignored. This feature is useful if the temperature sensor is removed for maintenance.

The flow equation for volumetric flowmeters is:

$$\text{Mass Flow} = R \times \text{Density}$$

where R is the flowrate defined in sections 3.3.1 and 3.3.2.

Density is the density determined from the temperature-density table.

When programming the temperature-density table, the density can be programmed in any units, but the units must be consistent with the flowrate R, and the required units for MASS flow. For example, if R is in litres and the mass is required in kilograms, then the density must obviously be programmed as kg/litre.

28 Temperature Compensation

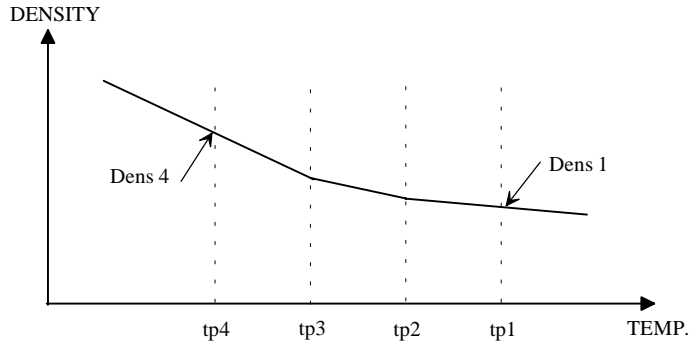

The above figure shows the temperature-density points for a 4 point table. Above tp4, the curve has the same gradient as between tp3 and tp4, and below tp1, the curve has the same gradient as between tp1 and tp2.

Differential Pressure Devices

For differential pressure devices the Mass flowrate is defined as:

$$\text{Mass Flow} = S \times A^{1/2} \times \text{Density}^{1/2}$$

$$\text{where } S = \frac{\text{Mass Flowrate at 20mA}}{(\text{Density at reference conditions})^{1/2}}$$

The Mass flowrate at 20mA and the corresponding reference density are provided by the flowmeter supplier and S is then calculated from the above equation and programmed during Calibration.

For differential pressure devices, the Gross Total is calculated as:

$$\text{Volume Flow} = S \times A^{1/2} \times \frac{1}{\text{Density}^{1/2}}$$

4.4 COMPENSATION FOR PETROLEUM LIQUIDS

The petroleum correction program uses the American Petroleum Institute equations described in API Standard 2540. For US units, the equations leading to Table 24A, 24B and 24D are used and, for metric units, Table 54A, 54B and 54D equations are used. These Tables are entitled:

Table 24A	Correction of Volume for Generalized Crude Oils to 60°F against Relative Density 60/60°F.
Table 24B	Correction of Volume for Generalized Products to 60°F Against Relative Density 60/60°F
Table 24D	Correction of Volume for Generalized Lubricating Oils to 60°F against Relative Density 60/60°F.
Table 54A	Correction of Volume for Generalized Crude Oils to 15°C against Density at 15°C.
Table 54B	Correction of Volume for Generalized Products to 15°C Against Density at 15°C.
Table 54D	Correction of Volume for Generalized Lubricating Oils to 15°C against Density at 15°C.

Based on the programmed density and the measured temperature, the software derives a volume correction factor (VCF). The gross (uncompensated) rate is multiplied by the VCF to give the net compensated total.

For US units, the density is programmed as the Relative Density (SG) and the volume is referenced to 60°F. For Metric units, the density is programmed as the Density in kg/m³ and the volume is referenced to 15°C.

Five product groups are defined by the equations and, during the Calibration routine, the relevant product group must be selected. The product groups and the relevant densities which can be programmed are as follows:

30 Temperature Compensation

Product Group	Relative Density	Density (kg/m³)
Crude Oil	0.751 - 1.000	750 - 1000
Jet Fuels, Kerosene		
+ Solvent	0.751 - 0.850	750 - 850
Gasoline	0.641 - 0.800	640 - 800
Lube Oil	0.851 - 0.960	850 - 960
Diesel, Heating		
+ Fuel Oils	0.801 - 1.100	800 - 1100

When programming the density, the values must be entered within these specified limits otherwise an error message will be displayed, prompting the operator to check the parameters.

4.5 COMPENSATION FOR LIQUEFIED PETROLEUM GAS (LPG)

The LPG correction program uses the American Petroleum Institute tables to volume correct the LPG to a reference temperature of 60°F for US units and 15°C for Metric units. The program uses an internally stored table to correct to the following standards:

US units	API Table 34 for correction of volume to 60°F against relative density 60/60°F for liquefied petroleum gases.
Metric units	API Table 54 for Reduction of Volume to 15°C against density at 15°C for liquefied petroleum gases.

For US units the density is programmed as the Relative Density (SG) and the volume is referenced to 60°F. For Metric units the density is entered as kg/litre and the volume is referenced to 15°C.

When programming the density, the values must be within the following limits, otherwise an error message will be displayed.

US units	0.501 to 0.600
Metric units	0.500 to 0.600 kg/litre

The temperature compensation is performed over a temperature range of -45°C to 60°C (-49°F to 140°F).

4.6 DENSITY METER INPUT

Density correction is available on the Model 405LA where a density meter is connected across the temperature inputs (Terminal 5) in place of a temperature transmitter. The densitometer must have a 4-20mA output.

During Calibration, the density at 4mA and 20mA can be programmed and the mass flow for volumetric flowmeters is:

$$\text{Mass Flowrate} = R \times \text{Density}$$

where R is the flowrate defined in sections 3.3.1 and 3.3.2.

Density is the density input.

If the input falls below 3.5mA, an error status, "Err 12" is displayed.

Differential Pressure Devices

For differential pressure devices the Mass flowrate is defined as:

$$\text{Mass Flow} = S \times A^{1/2} \times \text{Density}^{1/2}$$

$$\text{where } S = \frac{\text{Mass Flowrate at 20mA}}{(\text{Density at reference conditions})^{1/2}}$$

The Mass flowrate at 20mA and the corresponding reference density are provided by the flowmeter supplier and S is then calculated from the above equation and programmed during Calibration.

The Gross Total is calculated as:

$$\text{Volume Flow} = S \times A^{1/2} \times \frac{1}{\text{Density}^{1/2}}$$

5. OPTIONS

5.1 THE 4-20mA OUTPUT OPTION

The 4-20mA output option provides an analog output of rate as either a 4-20mA current or a 0-10 Volt level. All output signals are electrically isolated from the instrument power supply and signal inputs to ensure minimum interference. The 4-20mA is temperature compensated (if selected) and is directly proportional to the displayed rate.

Either 2 wire current transmission is available with the loop powered internally, or 3 wire transmission from an external loop supply.

A block diagram of the output is shown below and various methods of interconnection are outlined on the following pages.

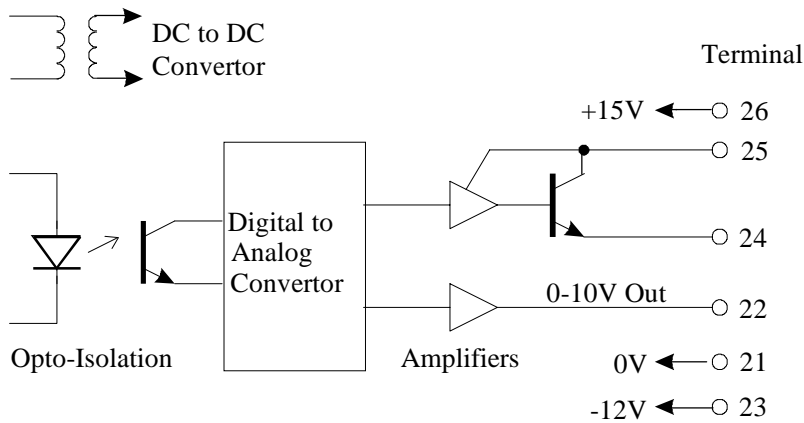

34 Options

5.1.1 Load Specification

Maximum load which the output can drive:

Internally powered loop: 500 ohms
Externally powered: $R = (V-5)/.02$
where V is the external loop voltage
R is the maximum load in ohms.

Output impedance of 0-10 Volt source: 100 ohms

5.1.2 Calculation

Parameters relating to this option are programmed when calibrating the instrument (see section 6) and provide for:

- ♦ Defining the rate which is equivalent to 4mA or 0 volts.
- ♦ Defining the rate which is equivalent to 20mA or 10 volts.
- ♦ Selecting the output range as 4-20mA (which also gives 2-10 volts on the voltage output circuit) or as 0-10 volts (which gives 0-20mA on the current output circuit).

By being independently able to set the output range, the instrument can effectively be programmed to amplify the input signal. In driving chart recorders, for example, this enables the output to zoom in on a particular operating area, instead of having to display the full operating range of the transducer.

For example, 4mA may be set as 0 litres/min and 20mA as 100/litres. However, the user could set 4mA as representing 100 litres/min and 20mA as representing 120 litres/min.

For rates or displayed values above and below the maximum and minimum values the output will remain at its 20mA or 4mA level respectively.

It should be noted that the output will be updated every 0.25 seconds in unison with the display and, between updates, the output value is constant.

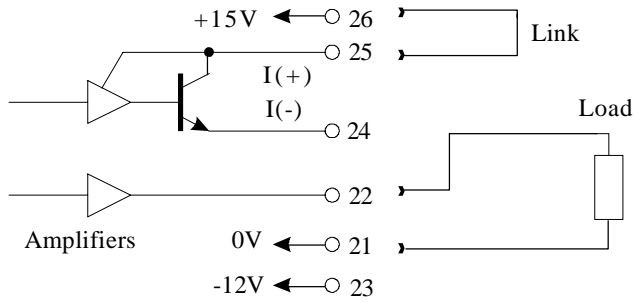

Voltage Output Configurations

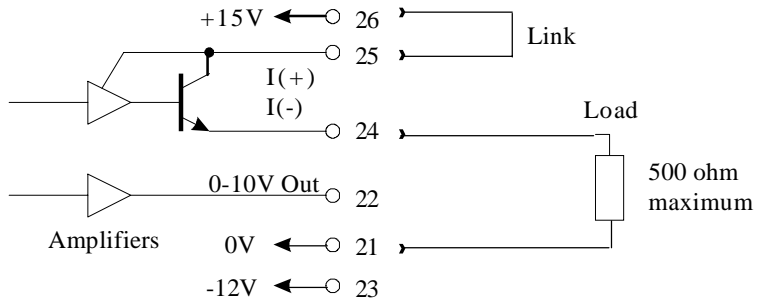

Two Wire Transmission (Internal Supply)

36 Options

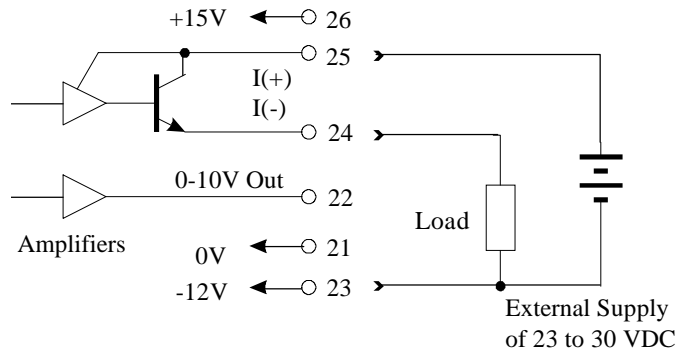

Three Wire Transmission (External Supply)

5.2 THE RS232/422/485 INTERFACE OPTION

With this option installed, the circuits for both the RS232 and RS422/485 are provided as standard. They can be used to interface to both printers and computers, and a number of standard protocols are built into the instrument.

5.2.1 Hardware

The following diagram provides an overview of the RS232/RS422/RS485 communications hardware. All three interfaces are available on the rear terminal strips and the user can select either one by making the appropriate connections.

The RS232 interface is primarily used with printers or for simple communication with a computer over a short distance. The RS422 and RS485 interfaces are used for communication over a long distance or in applications requiring multipoint communication.

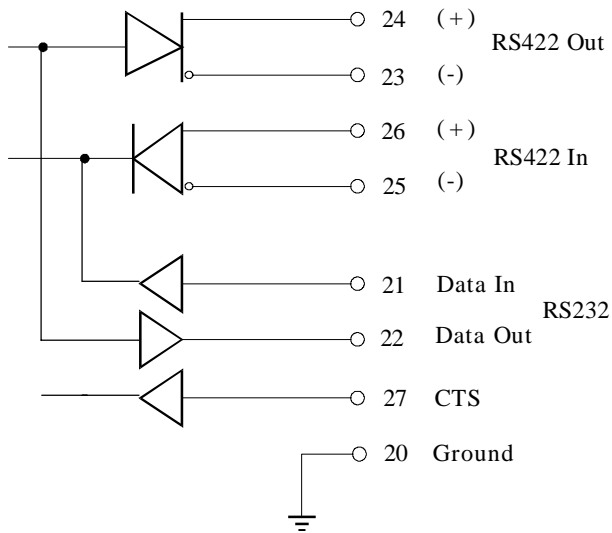

5.2.2 Multipoint Communication

Multipoint Communication is a system whereby a number of instruments can be addressed over a dual twisted pair interface. Up to 32 instruments can be connected to a common bus using the RS422 and RS485 interfaces as shown below.

To convert the RS422 interface to an RS485 interface, the RS422 (-) Data In Terminal must be connected to the RS422 (-) Data Out Terminal and the RS422 (+) Data In Terminal must be connected to the RS422 (+) Data Out Terminal. These connections will convert the RS422 4 wire interface to the RS485 2 wire interface, as shown in figure 2.

Each instrument can be programmed with a unique address which is used by the Master Controller (ie IBM/PC) to identify each instrument. The Controller will send the address down the line and will alert the relevant instrument. Subsequent software protocol will control the flow of data between the Controller and the Instrument.

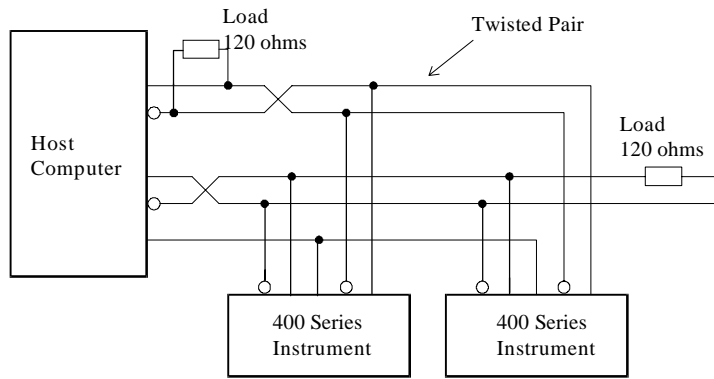

Figure 1 RS422 Interface

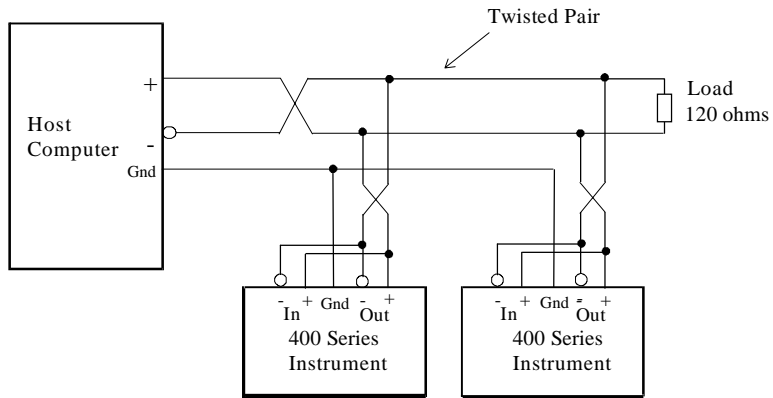

Figure 2 RS485 Interface

5.2.3 Communication Protocol

The Model 405L has a real time clock and enables the time and date to be set and printed on tickets. The date format can be European (days/months/years) or USA (months/days/years), while the time is on a 24 hour clock.

Note that the clock will only retain its time for 3 days minimum if there is no power connected to the instrument. After this period, the clock may need to be reset.

The baudrate, parity and wordlength can be programmed during calibration and the user must ensure that these correspond to the setting on the printer or computer with which the 405 is communicating.

The software protocols can be selected during Calibration to provide standard interfaces to a number of printers and computers. Since other interfaces will continue to be added, the user should consult the manual "*The RS232/422/485 Communications Option for the 400 Series, Version 2*", for the latest protocols and printer drivers.

Printer

A ticket is printed each time the RESET key is pressed. The instrument prints the ticket before resetting the resettable total. Protocols are provided to drive the following printers:

- 1 Standard Computer Printer (Note that the printer must have an RS232 Serial Interface).
- 2 EPSON CTM290 Slip Printer.
- 3 Contrec Model 624.
- 4 EPSON TM290-2 Slip Printer.
- 5 Contrec Model 632-2.
- 6 Syntest SP-210 Printer.

The tickets can also be printed with a number of different units, including litres and gallons. The units are selectable from a pre-programmed list.

A CTS input is provided, and will prevent the instrument from transmitting any further characters to a printer if the printer buffer is full. The CTS input is usually connected to the "Data Buffer Full" output from the printer.

If the printer buffer is large enough to handle the messages output from the instrument, then this input need not be used and should be left unconnected.

Computer

The instrument receives and transmits messages in ASCII, with all command strings to the instrument terminated by a carriage return while replies from the instrument are terminated with a carriage return and a line feed.

Xon/Xoff protocol is also supported, and the instrument will automatically determine if the message sent by the host computer is preceded by an Xoff character. If it does recognise an Xoff as the first character of a command string, the instrument will automatically switch to Xoff/Xon protocol, and begin & end all messages with Xoff and Xon characters respectively. Xoff/Xon protocol is only available when the RS232 interface is selected.

During Calibration, the instrument can be programmed to operate in a full duplex or half duplex transmission mode. In full duplex mode, all commands sent to the instrument will be echoed back to the host computer. In half duplex, the commands are not echoed.

For more information on the computer interface please consult the manual *"The RS232/422/485 Communications Option for the 400 Series, Version 2"*.

5.3 THE RELAY OUTPUT OPTION

The Relay output option consists of two Form C relays which can be preset during calibration to energise when the rate or displayed value exceeds or drops below the preset values.

The "low" relay is energised whenever the rate is below the preset value, and the "high" relay is energised whenever the rate exceeds the preset value. The preset values are programmed during calibration as described in section 6.

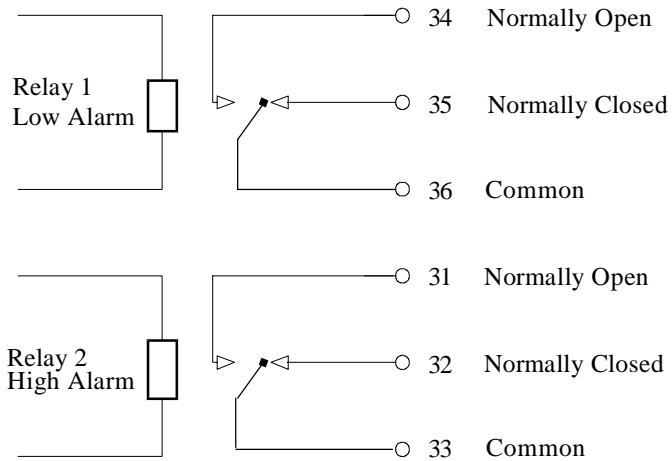

6. CALIBRATION

The Calibration routine enables the Setup Parameters to be programmed, as well as enabling the input signals to be checked.

The calibration routine can be entered in two ways:

- 1 By connecting a wire link (or switch) to the rear terminal strip across terminals 1 and 2 or,
- 2 By pressing the TOTAL key and, while still holding, pressing the RESET key. Both keys must then be held for approximately 6 seconds. This second method of access can be disabled during the calibration so that it is only possible to enter the calibration routine via the link across terminals 1 and 2.

The key switch actions are as follows:

RATE	will change a flashing digit, to the next digit.
TOTAL	will increment a flashing digit or change a parameter selection.
RESET	will reset a flashing digit to zero.
DISPLAY (Program)	will step through the program sequences.

Note that the arrows in the Rate and Total key switches indicate that these switches can be used to change and increment digits respectively.

In stepping through the program sequence, the Parameter Description is always displayed first, followed by the actual value or parameter. When a value or parameter can be changed, it is always shown as flashing, and the LED's in the switch panels are lit if that key switch can be used to change a value.

44 Calibration

On first entering the Calibration routine, the display will show the Model number followed by:

CAL	Setup Program parameters.
Options	Options (if installed).
Test	Check Input Signals.
End	Exit to Normal Operation.

The user can toggle between these modes using the TOTAL switch and by using the DISPLAY switch, select the appropriate mode.

To exit Calibration, step through the Setup program or Test program until the end, and press the DISPLAY switch when **End** is displayed, (ensure the calibration link is removed).

6.1 PROGRAMMING THE SETUP PARAMETERS

<i>Step</i>	<i>Display</i>	<i>Description</i>	<i>Text Ref</i>
1	CAL	Select the Calibrate mode to setup program parameters.	
	OPTIONS	Options (if installed)	6.2
	TEST	Select the test mode to check input signals.	6.3
	END	Exit to normal operation.	
	<i>The following steps are displayed if CAL is selected.</i>		
2	RESTOT	Reset all <u>totals</u> to zero.	
	xxxxxx	To clear all totals (net, gross and accumulated) press the reset key.	
3	FL INP	Select either a single frequency input or a quadrature input (ie two pulses from a single flowmeter). The analog input on the Model 405LA can also be selected.	3.2
	single	Single Input.	
	quad	Quadrature Input.	
	analog	Analog Input (only for Model 405LA)	
4	CORRCT	Select either a linear input or non-linear correction for the flowmeter input. If an analog input is selected the input relationship is either linear or square root.	
	Linear	Linear Correction, or	
	Nonlin	Non-Linear Correction (only on freq input).	3.5
	Sq rt	Square Root Input (only if analog input).	3.3.2

46 Calibration

<i>Step</i>	<i>Display</i>	<i>Description</i>	<i>Text Ref</i>
5	SCALE		
		<i>If <u>linear correction</u> is selected, the scaling factor is programmed as follows.</i>	
	Fact	Enter the <u>Scaling factor</u> (K-factor) of the flowmeter. The program then steps to step 8.	3.3
		<i>If <u>non-linearity correction</u> is to be programmed, up to 10 frequencies and scaling factors can be entered.</i>	
	Freq 1	Freq1 is programmed to the first frequency point in the range of 0 to 9999Hz.	3.5
	Fact 1	This is the K-factor of the flowmeter (ie. pulses per gal, etc) at Freq1. The digits before the decimal point (whole numbers) are programmed first, followed by the decimals. The scaling factor can be programmed in the range of 0.1000 to 50,000.	
	Freq2	Freq2 is programmed to the second frequency point. If any Freq is set to 0, no further correction points can be programmed and the non-linearity correction is limited to that number of points.	
	Fact 2	Scaling Factor 2.	
	<i>to</i>		
	Fact 10	Scaling Factor 10. Note that Freq10 is not displayed since it must always be zero.	

Step	Display	Description	Text Ref
		<i>If an <u>Analog input</u> is programmed, the value, S, is entered.</i>	
	Fact	This is the value, S, which must be entered.	
6	CUTOFF x.xx	Displayed only if an analog input is selected. The Cutoff prevents display and integration of the flowrate below x.xx% of the span.	
7	F dPt	Number of decimal points with which the <u>Rate</u> is to be displayed between 0 to 0.00000.	
8	t.base	The <u>Timebase</u> with which the Rate is calculated must be entered as:	3.3
	60secs	units/min	
	hours	units/hour	
	days	units/day	
	secs	units/second	
9	FILTER	The <u>filter constant</u> for filtering the rate display and the 4-20mA output.	3.3.3
	1	No filtering.	
	to		
	99	Very heavy filtering.	
10	TOTCON	A <u>division factor</u> to convert the totals to different units from those used for rate (ie gallons/min and barrels).	3.4
	1	Rate and totals have the same engineering units.	
	x.xxxx	Other factors can be programmed between 0.01 and 2000.	

48 Calibration

<i>Step</i>	<i>Display</i>	<i>Description</i>	<i>Text Ref</i>
11	<i>t.dPt</i>	Number of decimal points with which the <u>Net</u> (resettable) total is displayed between 0 to 0.000.	
12	<i>A.dPt</i>	Number of decimal points with which the <u>Accumulated</u> (non resettable) total is displayed between 0 to 0.000.	
13	<i>t.c.</i>	The type of <u>Temperature Compensation</u> can be selected as follows:	4
	<i>none</i>	No temperature compensation.	
	<i>genliq</i>	Volume Correction for General liquids.	4.3
	<i>gendns</i>	Density Correction for general liquids.	4.2
	<i>petrol</i>	Compensation for Petroleum products.	4.4
	<i>LPG</i>	Compensation for Liquid Petroleum Gas.	4.5
	<i>dens</i>	Density Meter Input (Model 405LA only).	4.6

If "none" (no temperature compensation) is selected the program will go to Step 20 (ACCESS).

If a Density Meter Input is selected the following steps are displayed:

14	<i>d4</i>	The density at 4mA input is programmed.	4.6
15	<i>d20</i>	The density at 20mA input is programmed.	
		<i>The program will now go to Step 21.</i>	

All other selections result in the following steps being displayed:

14	<i>t.</i>	Select either <u>US units</u> or <u>metric</u> units as the basis of the temperature compensation	4
	<i>•F</i>	US units.	
	<i>•C</i>	Metric units.	

If the instrument has a direct RTD input (Model 405LR) the temperature can be adjusted (offset) to correct for the RTD tolerance.

15	<i>ADJ t</i>	Adjust the temperature displayed during <i>test</i> .	
	<i>xx.xx</i>	Input the offset. (The first digit is 0 for positive or - for negative.)	

Step	Display	Description	Text Ref
		<i>If the instrument has a 4-20mA temperature input (Model 405LA), then the 4mA and 20mA points are entered.</i>	
15	IP4	Enter the temperature that corresponds to 4mA in either °F or °C depending on the units selected in Step 15.	4.1
16	IP20	Enter the temperature that corresponds to 20mA.	

Program steps 18 to 20 depend on which option for temperature compensations was selected in Step 13 and are individually described.

Volume Correction for General Liquids

17	REF °F (°C)	Program the base temperature for the compensation. Enter the temperature in °F or °C depending on the units selected in Step 15.	4.2
18	COEF A	Enter the thermal coefficient of change "a" as a%. Hence if the coefficient of expansion is 0.0029/°C enter the % change as 0.29000.	

The program will now go to Step 20.

Density Correction for General Liquids

17	NotP x	Number of temperature-density correction points up to five. If x is set to 1, a fixed density can be programmed (ie. the density is not dependant on the temperature).	4.3
18	tp1	Temperature point 1.	
19	dens1	Density 1.	

50 Calibration

<i>Step</i>	<i>Display</i>	<i>Description</i>	<i>Text Ref</i>
-------------	----------------	--------------------	-----------------

Up to 5 correction points can be entered.

Petroleums

17		Select the <i>petroleum type</i> .	4.4
	<i>CRUDE</i>	Crude oils as per tables 24A & 54A.	
	<i>LUBE</i>	Lube oils as per tables 24D & 54D.	
	<i>OILS</i>	Fuel oils & heating oils, and diesel (tables 24B & 54B).	
	<i>JET</i>	Jet fuels, kerosenes and solvents (tables 24B & 54B).	
	<i>GAS</i>	Gasolines and naphthenes (tables 24B & 54B).	
18	<i>dn 60°F</i> <i>or</i> <i>(dn 15°C)</i>	If US units are selected this is the Relative <i>Density</i> (SG). If Metric units are selected, the Density at 15°C in kg/m ³ is programmed.	4.4

The program will now go to Step 20.

Liquid Petroleum Gas

17	<i>dn 60°F</i>	If US units are selected, the Relative Density (SG) is programmed. If Metric units are selected, the Density in kg/litre is programmed.	4.5
20	<i>ACCESS</i>	Enable access to calibration routine via the front keyboard only.	
	<i>Front</i>	Enable access via front keyboard.	
	<i>No Acc</i>	Disable access via front keyboard.	

6.2 PROGRAMMING OPTIONS

<i>Step</i>	<i>Display</i>	<i>Description</i>	<i>Text Ref</i>
1	OPTIONS	Options (if installed).	
	<i>Test</i>	Check the Input Signals.	6.2
	<i>End</i>	Exit to normal operation.	
	<i>CAL</i>	Program Setup Parameters.	6.1

If the 4-20mA output option is installed, the following will be displayed:

2	OUTPUT	Select either 4-20mA or 0-10 volt.	
	4-20	4-20mA (also 2-10 volts).	5.1
	0-10	0-10 V (also 0-20mA).	

3	OP 4	Flowrate at 4mA or 0 volts.	
	xxxx	Enter flowrate.	

4	OP20	Flowrate at 20mA or 10 volts.	
	xxxx		

If the RS232/422/485 option is installed, the following will be displayed:

5	DF	Date Format.	
	Eur	European (ie. days/months/years).	5.2
	USA	USA (ie. months/days/years).	
6	Date	Enter date as:	
	xx:xx:xx	Years:Months:Days.	
7	HOUR	Enter time as a 24 hour clock.	
	xx:xx	Hours:Minutes.	

52 Calibration

<i>Step</i>	<i>Display</i>	<i>Description</i>	<i>Text Ref</i>
8	BAUD xxx	Baudrate 300, 600, 1200, 2400, 4800 and 9600 .	
9	DATA 7 8	Word length. 7 bits. 8 bits.	5.2
10	PARITY NP OP EP	Parity. No Parity. Odd Parity. Even Parity.	
11	SIGNAL rs232 rs422	Signal Type. RS232. RS422/RS485.	
12	ID NO 0 1-99	Unit Identification Number. None. Id Number.	
13	PTYPE xx 00 01 02 03 04 05 20	Printer/Computer Type. Standard Computer Printer. EPSON CTM 290 Slip Printer. Contrec Model 624 Printer. EPSON TM 290-2 Slip Printer. Contrec Model 632-2 Printer. Syntest SP-210 Printer. Computer.	

<i>Step</i>	<i>Display</i>	<i>Description</i>	<i>Text Ref</i>
-------------	----------------	--------------------	---------------------

If a Printer Protocol is selected, the following message is displayed:

- | | | | |
|----|----------------|-------------------------------|--|
| 13 | UNIT xx | Units of measurement printed. | |
| | 00 | None. | |
| | 01 | Litres (Ltrs). | |
| | 02 | Gallons (Gals). | |
| | 03 | Barrels (bbls). | |
| | 04 | Pounds (lbs) | |
| | 05 | Grams (gms) | |
| | 06 | Kilograms (kg) | |
| | 07 | Tons (ton) | |

If a Computer Protocol is selected, the following message is displayed:

- | | | | |
|----|-------------|------------------------|--|
| 13 | ECHO | ECHO Command. | |
| | On | Echo (Full Duplex). | |
| | Off | No Echo (Half Duplex). | |

If the Relay Option is installed, the following will be displayed:

- | | | | |
|----|--------------------------|--|-----|
| 14 | AL: Hi
xxxxxx | High Alarm switching point. The high relay will energise if the flowrate exceeds this value. | 4.3 |
| 15 | AL: Lo
xxxxxx | Low Alarm switching point. The low relay will energise if the flowrate falls below this value. | |

6.3 CHECKING THE INPUT SIGNAL

<i>Step</i>	<i>Display</i>	<i>Description</i>	<i>Text Ref</i>
1	TEST	Check the Input Signals.	
	OPTIONS	Options (if installed).	6.2
	CAL	Program Setup Parameters.	6.1
	END	Exit to normal operation.	

The following steps are displayed if **TEST** is selected.

- 2 **Sr x.xx** Software revision number.
- 3 *If the instrument is a Model 405LA and temperature or density correction is selected, the display will show:*

**T4-20 or
D4-20
xx.xx** Displayed for 1 second to indicate input from the 4-20mA temperature input. The input current is then displayed.

If the instrument is a Model 405LR and temperature correction is selected, the display will show:

**RTD
xxx.xx** Displayed for 1 second to indicate the RTD. The measured temperature is then displayed.

- 4 *Use the DISPLAY switch to step to the Flow Input.
If the Flow Input is a Single frequency input, the display will show:*

**Freq
xxxx.x** Displayed for 1 second followed by the actual frequency. Frequency in Hz.

<i>Step</i>	<i>Display</i>	<i>Description</i>	<i>Text Ref</i>
<i>If the Flow Input is a Quadrature frequency input, the display will show:</i>			
	Freq	Displayed for 1 second followed by the actual frequency.	
	xxxx.x	Frequency in Hz. If the flow is reversing a negative sign will appear.	
<i>If the Flow Input is an analog signal the display will show:</i>			
	F4-20	Displayed for 1 second followed by the actual current.	
	xx.xx	mA.	
<i>If the RS232/422/485 option is installed, the display will then show:</i>			
5	CLOC	Clock.	
	xx:xx:xx	Time in Hours:Mins:Sec.	

7. INPUT CIRCUITS

7.1 FLOW INPUTS

7.1.1 Frequency Inputs

The Model 405L has two pulse input circuits:

- ◆ Channel 1 is used with both single and quadrature input signals. The Channel can interface directly to
 - Turbine Flowmeters
 - Open Collector Outputs
 - Reed Switches
 - Logic Signals
 - Namur Sensors

- ◆ Channel 2 is used only when a quadrature input is selected, and becomes the 0° input while channel 1 becomes the 90° input. Channel 2 can interface directly to
 - an Open Collector
 - a Reed Switch
 - a Logic Signal
 - a Namur Sensor

The frequency input circuits for the Model 405L can be configured by the user to interface with most flowmeters. A small 8 pole DIL switch on the rear of the instrument is used to set up the input circuit to operate with different types of signals.

The input circuit is shown on page 59 and examples of flowmeter interconnections are given on pages 60 and 61.

Switch Settings

The following are recommended switch settings for different input signal types.

Note, input types d and e are only available on Channel 1. Channel 2 is limited to signal types a to c.

Input Signal Type	Input Terminals				Switch Settings							
	CH1		CH2									
	+	-	+	-	1	2	3	4	5	6	7	8
a. Logic Signal, CMOS, Pulse	9	8	3	8	off	off	off	off	on	off	off	off
b. Open Collector or Reed switch	9	8	3	8	off	off	off	off	on	off	on	off
c. Namur Proximity (set DC out to 8 volts)	11	9	11	3	on	off	on	on	on	on	off	off
<i>Channel 1 Only</i>												
d. Switch or Reed Switch with debounce circuit (200Hz max)	9	8			off	off	off	off	on	off	on	on
e. Coil (20mV P-P minimum)	9	8			off	on	off	off	off	off	off	off

General Specification

Switching Threshold: 2.5 Volts (except for input type c and e)

Maximum Input Voltage: 50V peak

Input Impedance

Input type a: 100K on channel 1
10K on channel 2

Input types b & d: 10K

Input type c: 1K

Input type e: 100K

Powering of Sensors

The Model 405L has a regulated DC output which can be used to power sensors. A trimpot on the rear of the instrument allows the voltage to be adjusted in the range of 8-24 Volts and the output can supply a maximum of 50mA.

Note that when using this DC output to power opto-sensors, some flowmeter manufacturers require that a current limiting resistor be used. Please refer to the flowmeter manufacturers data sheet if this is the case.

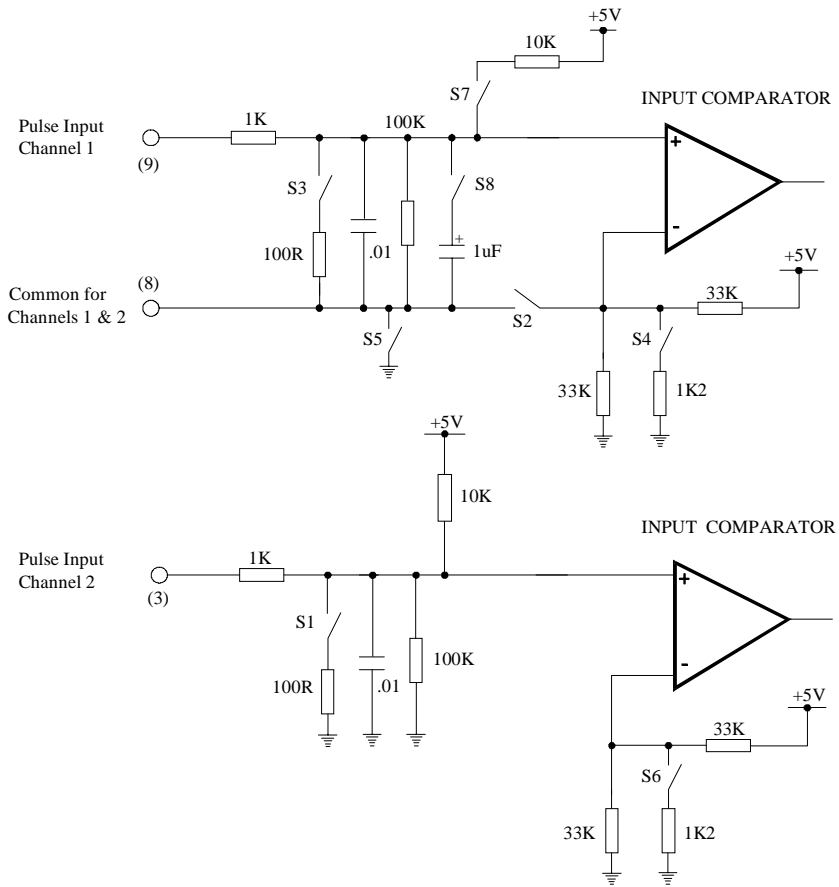

The Frequency Input Circuits

60 Input Circuits

1. Squarewave, CMOS or Pulse

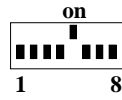
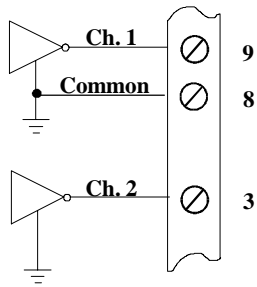

eg. vortex, pre-amplifiers
or magnetic flowmeters

2. Open-Collector

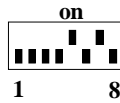
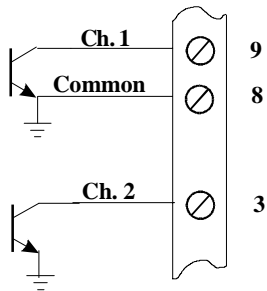

eg. preamplifiers
and opto-sensors

3. Reed Switch

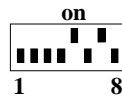
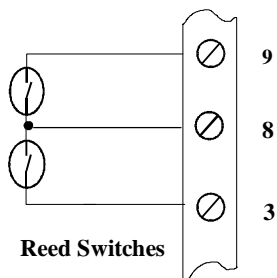

eg. positive displacement
flowmeters with reed switch
outputs.

4. Coils

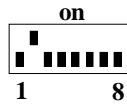
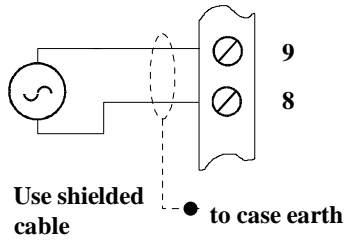

eg. millivolt signal from a turbine flowmeter (single input only)

5. Namur Proximity Switch

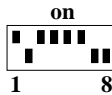
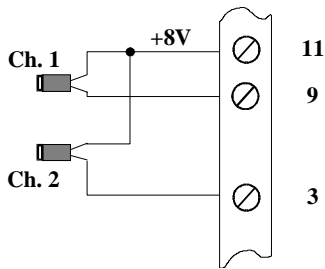

eg. positive displacement flowmeters with 2 wire proximity switch outputs

6. Opto-Sensors

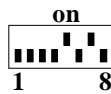
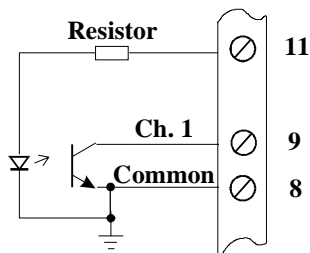

eg. pre-amplifiers and opto-sensors.

Note that the current limiting resistor may be required. See the flowmeter manufacturer's data.

62 Input Circuits

7.1.2 Analog Flow Input

On instruments with the Model number, 405LA, there is provision to accept an analog (4-20mA) input from a flowmeter. When the analog input is selected, the pulse inputs cannot be used.

The flowmeter and temperature (or density) sensor are connected as follows:

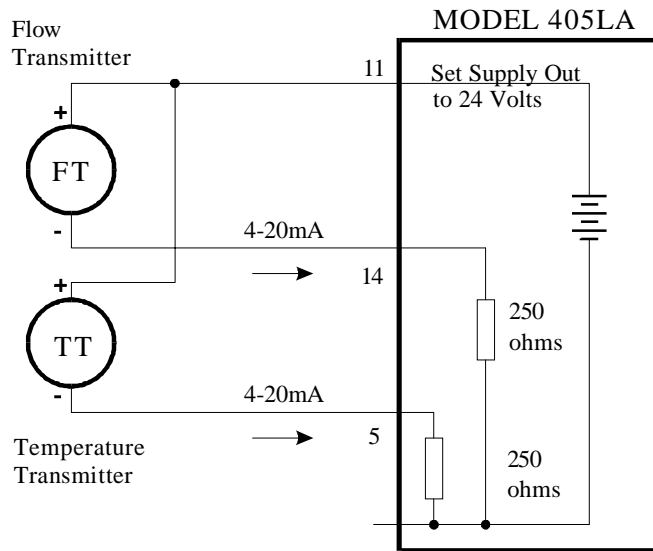

Shielding: When shielding the input signals, the shield should be connected to the case earth and not connected at the transmitter end (ie. ground at the instrument end only).

7.2 TEMPERATURE OR DENSITY INPUT

The Flow Computer can be supplied as:

- * Model 405LR Direct 4 wire Platinum RTD (PT100)
- * Model 405LA 4-20mA input which can be used for temperature or density.

RTD

Four wire RTD measurement is the most accurate form of measurement and can be used for measurements with the RTD up to 100 meters from the instrument. It is recommended to use shielded cable when interfacing to RTD's.

Two or three wire RTD's can be used in place of 4 wire RTD's, but 4 wires must be taken to the RTD and the signal and current wires joined as close to the RTD as possible.

With direct RTD measurement, the program automatically corrects for the non-linearity in the RTD.

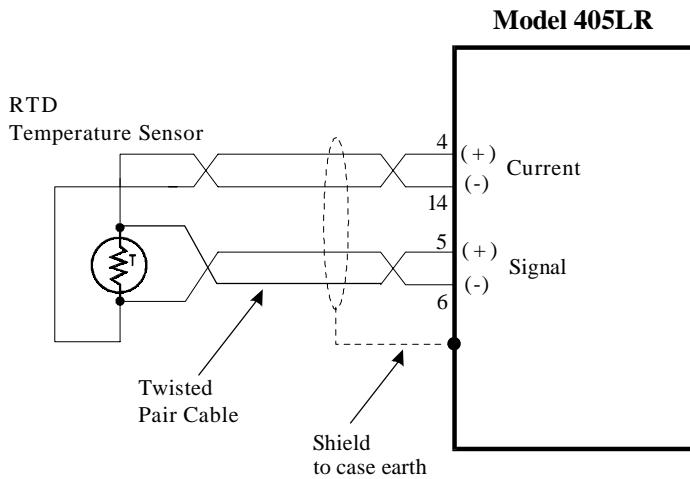

64 Input Circuits

When wiring the RTD, care must be taken to ensure the (+) of the Current on terminal 4 is connected to the same side of the RTD as the (+) of the signal on terminal 5. The RTD has no polarity and can be connected in either direction.

4-20mA

This input can function as either a temperature or density input. The instrument enables the 4mA and the 20mA points to be programmed. Unlike the direct RTD measurement, no correction is made for the non-linearity of the temperature or density sensor.

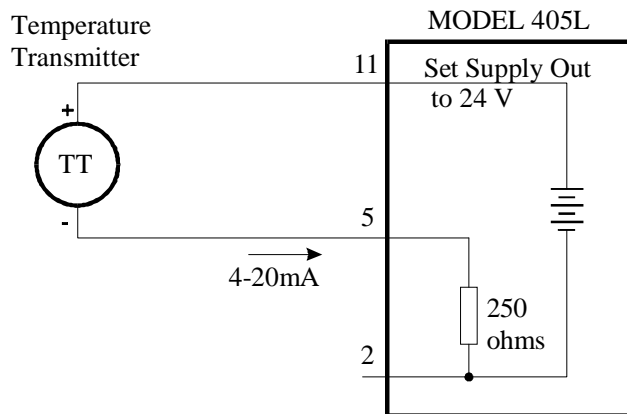

8. INSTALLATION

8.1 GENERAL

Terminal designations for the Model 405L Flow Computer are given on the following pages. The cutout hole in the panel should be 5.5" (139mm) wide x 2.6" (67mm) high. Two side clips are supplied to secure the instrument into the panel.

A case earthing point is provided via an earth lug on the side of the case. Note that this earthing point is for the case only and there is complete electrical isolation between this point and all electronic circuits. For EMC purposes, or when the instrument is connected to mains, this point must be connected to a good earth using a multi-stranded, braided wire or strap. All relay outputs are totally isolated from the case and from the internal circuitry.

A Supply Output voltage is provided to power sensors. This output will provide a regulated voltage of 8 to 24 volts and the voltage is adjustable by means of the potentiometer on the rear panel. Maximum current is 50mA and the instrument comes with the voltage factory set at 24 Volts. When the instrument is powered from a DC power source, the maximum output voltage on the Supply Output is the DC Input Voltage less 3.5 volts.

The instrument will operate from either 12 - 28 volts DC or from the mains. The mains voltage is factory set to either 95 - 135 VAC (110 VAC nominal) or 190 - 260 VAC (220 VAC nominal). An internal mains transformer provides full isolation between the mains and the electronic circuits.

The DC Ground terminal 12 provides a common ground for the 12 - 28 Volt power input, the 8 - 24 Volt output and the pulse output.

It is good practice to use shielded cables for all signal connections to the Model 405. Care must be taken to separate signal cables from power cables so as to minimise interference.

Overall shields should be connected to the case earth at the instrument end only. This connection should be as short as possible and connected to the earthing lug on the side of the case.

In order to comply with the requirements for Electromagnetic Compatibility as per EMC-Directive 89/336/EEC of the Council of European Community, this wiring practice is mandatory.

Although it is also possible to connect shields to the signal ground (terminal 2) this practice is not in accordance with EMC directives.

RC Networks for Interference Suppression

When driving highly inductive loads with the relay outputs, it is recommended that RC suppression networks (often called "Snubbers") are used for two reasons:

- ◆ To limit the amount of electrical noise caused by arcing across the contacts which may, in extreme cases, cause the microprocessor to act erratically.
- ◆ To protect the relay contacts against premature wear through pitting.

RC suppression networks consist of a capacitor and series resistor and are commonly available in the electrical industry. The values of R and C are dependant entirely on the load. However, if the user is unsure of the type of snubber to use, values of 0.25uF and 100 ohms will usually suffice. Note that only mains approved RC suppression networks should be used.

The basic principle of operation is that the capacitor prevent a series of sparks arcing across the contact as the contact breaks. The series resistor limits the current through the contact when the contact first makes.

8.2 WIRING DESIGNATIONS FOR THE MODEL 405L

<i>Terminal</i>	<i>Model 405LR</i>	<i>Model 405LA</i>
1	Calibration Link	Calibration Link
2	Signal Ground	Signal Ground
3	Flow Pulse Input (Channel 2)	Flow Pulse Input (Channel 2)
4	PT100 I (+)	Not To Be Used
5	PT100 Signal (+)	Temperature Input (4-20mA)
6	PT100 Signal (-)	Not To Be Used
7	Flow Alarm	Flow Alarm
8	Flow Common (-)	Flow Common (-)
9	Flow Pulse Input (Channel 1)	Flow Pulse Input (Channel 1)
10	Pulse Out	Pulse Out
11	DC Power Out (8-24 VDC)	DC Power Out (8-24 VDC)
12	DC Ground	DC Ground
13	DC Power Input	DC Power Input
14	PT100 I (-)	Flow Input (4-20mA)

<i>Terminal</i>	<i>Analog Flow Output (4-20mA)</i>	<i>RS232/422/485</i>
20	Not To Be Used	RS232 Signal Ground
21	0 Volts	RS232 Data In
22	0-10 Volts	RS232 Data Out
23	-12 Volts	RS422/485 (-) Data Out
24	I(-)	RS422/485 (+) Data Out
25	I(+)	RS422/485 (-) Data In
26	+15 Volts	RS422/485 (+) Data In
27	Not To Be Used	RS232 CTS

<i>Terminal</i>	<i>Relay Option</i>
31	Relay 2 - Normally Open
32	Relay 2 - Normally Closed
33	Relay 2 - Common
34	Relay 1 - Normally Open
35	Relay 1 - Normally Closed
36	Relay 1 - Common

9. TROUBLE SHOOTING

9.1 ERROR CODES

The instrument has extensive self test facilities and will display an error code if it detects an invalid condition. If the instrument displays an error code other than those listed below, please contact the factory.

Error codes are displayed as "Err 12" and a list of commonly encountered codes are given below:

Error Codes

Input Errors

- 11 Invalid input configuration programmed.
- 12 The Temperature or Density Input is out of range.
- 13 Quadrature error detected. That is, an unequal amount of pulses detected on the inputs (see section 3.2).
- 14 Communications Input error (RS232/422/485 Interface).
- SIGNAL Analog flow input signal is below 3.5mA (405LA only).
(See Section 3.3.2)

Output Errors

- 21 Invalid output configuration.
- 22 Communications error - Baud rate not set.
- 23 Communications error - Printer fault.

Calibration Errors

- 30 Zero Value not allowed.
- 31 Outside Allowable Temperature Range.
- 32 Outside Allowable Density Range.
- 33 Invalid Printer Type.
- 34 Invalid Volume Units selected.

Index

4-20mA Output, 33

A

Access, 50
 Accumulated, 12
 Analog Flow Input, 62
 Analog Input, 15
 API Standard 2540, 29

B

Baudrate, 52
 Bi-directional Flow, 13

C

Calibration, 43
 Calibration
 Certificate, 19
 Clock, 40
 Coefficient of
 Expansion/°C, 26
 Coils, 61
 Communications, 37
 Computer, 41
 Crude Oils, 29
 Cutoff, 15
 Cutout, 6

D

Date, 40
 DC Output, 58
 Decimal Points, 48
 Density, 27
 Density Correction, 27

Density Meter, 24, 32
 Diesel, 30
 Differential Pressure, 15
 Dimensions, 6
 Display Key, 6

E

Earthing Point, 65
 Electrical Noise, 66
 Electronic Counter, 22
 Error Codes, 68

F

Filtering, 16
 Flow Alarm, 21
 Flow Inputs, 56
 Flowrate, 14
 Frequency Input, 14
 Frequency Inputs, 56
 Frequency Range, 6

G

Gasoline, 30
 Gross Total, 12
 Ground, 65

I

Impulse Counter, 22
 Input Circuits, 56
 Installation, 65
 Interference, 66
 Isolation, 65

J

Jet Fuels, 30

K

K-factor, 14
 Kerosene, 30

L

Liquefied Petroleum
 Gas (LPG), 31
 Lubricating Oils, 29

M

Mass Flow, 27
 Model Number
 Designation, 5
 Model Numbers, 1
 Multipoint
 Communication, 38

N

Non-Linearity
 Correction, 19
 Non-Volatile Memory, 6

O

Open-Collector, 60
 Operating
 Temperature, 6
 Opto-Sensors, 58
 Output Pulse, 21

P

Parity, 52
 Petroleum Liquids, 29
 Power Requirements, 6
 Printer, 40
 Protocol, 40

Proximity Switch, 61
Pulse output, 6

Q

Quadrature Input, 13

R

Rate, 6
Reed Switch, 60
Relative Density, 29
Relay Output, 42
Reset Key, 12
RS232, 37
RS232/422/485
 Interface, 37
RS422, 37
RS485, 38
RTD Input, 24
RTD Measurement, 63
RTD Type, 6

S

Scaling Factor, 14
Scaling Range, 6
Self Test, 68
Setup Parameters, 43
Shielding, 62
Snubbers, 66
Solvent, 30
Specification, 6
Square Root, 45
Squarewave, 60
Switch Settings, 57

T

Tables, 29
Temperature, 12

Temperature Adjust, 24
Temperature
 Compensation, 23
Terminal, 67
Thermal Coefficient of
 Expansion, 25
Time, 40
Timebase, 47
Total, 12
Total Conversion, 18
Transducer Supply, 6
Trouble Shooting, 68

V

Volume Correction
 Factor, 29
Volume Correction for
 General Liquids, 25
Volumetric Flowrate, 14

W

Wiring Designations, 67