

**BATCH CONTROLLERS  
MODELS 414D & 414B**



November 1995



# CONTENTS

<b>1. Introduction</b>	3
1.1 Model Number Designation	5
<b>2. Specification</b>	6
<b>3. Operation</b>	8
3.1 Front Panel Operation	9
3.2 Batch Operations	12
3.2.1 Control Relay Outputs	14
3.2.2 Signal Timeout	15
3.2.3 End of Batch	16
3.2.4 Auto Restart	17
3.2.5 Automatic Overrun Compensation	18
3.3 Calculation of Rate and Total	19
3.3.1 Frequency Input	19
3.3.2 Filtering	20
3.4 Total Conversion	22
3.5 The Output Pulse and Flow Alarm (Model 414D Only)	23
<b>4. Options</b>	25
4.1 The RS232/422/485 Interface Option	25
4.1.1 Hardware	25
4.1.2 Multipoint Communication	26
4.1.3 Communication Protocol	28
<b>5. Calibration</b>	30
5.1 Programming the Setup Parameters	32
5.2 Entering the Batch Parameters	34
5.3 Programming Options	36
5.4 Checking the Input Signal	38

<b>6. Input Circuits</b>	39
6.1 Input Circuit for the Model 414D	39
6.2 Input Circuit for the Model 414B	44
6.3 Remote Switches	47
<b>7. Installation</b>	48
7.1 General	48
7.2 Wiring Designations for the 414D & 414B	50
<b>8. Trouble Shooting</b>	51
8.1 Error Codes	54
<b>Index</b>	55

# 1. INTRODUCTION

The Models 414D and 414B Batch Controllers accept pulse or frequency flow signals and automatically control the batching of fluids via a one or two stage control valve.

The instruments are extremely flexible and easy to operate, with a four key, front panel operation that enables the batch quantity to be set, and batches to be started or stopped.

This manual covers both the Model 414D and 414B. While both versions have identical software and outputs, the Model 414D has an input signal conditioning card, while the Model 414B accepts only basic pulse and squarewave signals.

**Model 414D** Accepts most frequency and pulse signals, including mV outputs from turbine flowmeters, and 2 wire proximity switch outputs. It also enables all four front panel switches to be remotely connected via the rear terminal strip.

The Model 414D has a scaled pulse output for driving remote counters, together with a flow alarm output.

**Model 414B** Accepts basic pulse and squarewave signals. Only the RUN and STOP switches are available via the rear terminals.

Both instruments are fully programmable, with all calculation constants set via the front panel switches and stored permanently in non-volatile memory.

This instrument conforms to the EMC-Directive of the Council of European Communities 89/336/EEC and the following standards:

*Generic Emission Standard EN 50081-1* Residential, Commercial & Light Industry Environment.

*Generic Emission Standard EN 50081-2* Industrial Environment.

## 4 Introduction

*Generic Immunity Standard EN 50082-1* Residential, Commercial & Light Industry Environment.

*Generic Immunity Standard EN 50082-2* Industrial Environment.

In order to comply with these standards, the wiring instructions in Section 8.1 must be followed.

## 1.1 MODEL NUMBER DESIGNATION

The Model number of an instrument describes which input and output options are installed and the AC mains voltage rating.

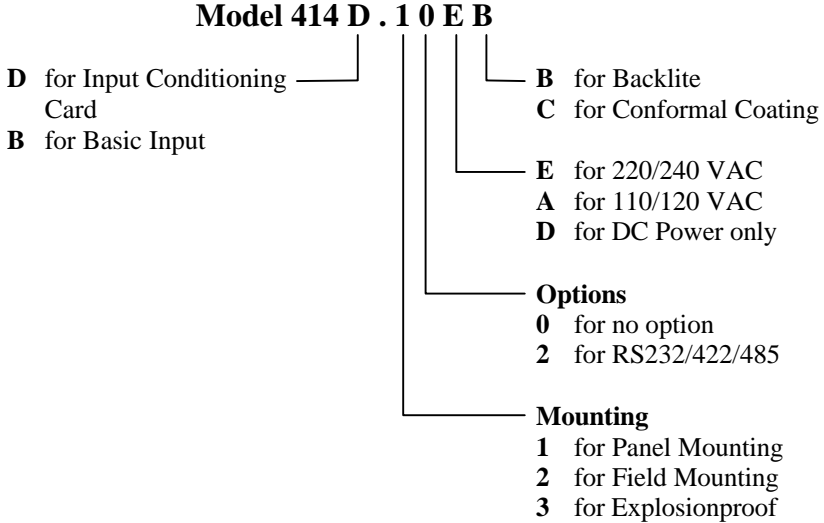

The Model Number of the instrument is displayed on first entering the Calibration Mode (see Section 5).

# 2. SPECIFICATION

## *General*

Display:	6 digit LCD. 0.7" (17.8mm) high digits.
Display Update Rate:	0.25 seconds.
Transducer Supply:	8-24VDC field adjustable. 50mA maximum.
Power Requirements:	11.5 to 28.5 volts DC. 130mA typical current (no options). AC Mains: Set internally to 95 - 135 VAC or 190 - 260 VAC.
Operating Temperature:	0 to 55°C standard.
Dimensions:	5.7" (144mm) wide x 2.8" (72mm) high x 7.0" (178mm) deep.
Cutout:	5.5" (139mm) wide x 2.6" (67mm) high.

## *Frequency Input*

Frequency Range:	Minimum: 0.25Hz on Rate. 0Hz on Total.
	Maximum: 10KHz.
Input Circuits:	See Sections 6.1 and 6.2.
Scaling Range:	0.1000 to 50,000.

## *Relay Outputs*

Maximum Switching Power:	1250VA.
Maximum Switching Voltage:	250VAC, 30VDC.
Maximum Switching Current:	5 Amps.

*Pulse Output (Model 414D Only)*

Pulse Width:	10mSec (negative going pulse).
Maximum Duty Cycle:	49 pulses per second.
Scaling:	The pulse output is scaled and outputs one pulse each time the accumulated total increments.

# 3. OPERATION

The Models 414D and 414B Batch Controllers use a low power CMOS microprocessor to perform all control functions and calculations.

Both instruments are fully programmable with all operating parameters and calculation constants user programmable. (See Section 5 entitled "Calibration" for information on programming.) All parameters and constants are stored in a non-volatile memory which retains data without battery backup for a minimum of 10 years.

A block diagram of the instrument is shown below.

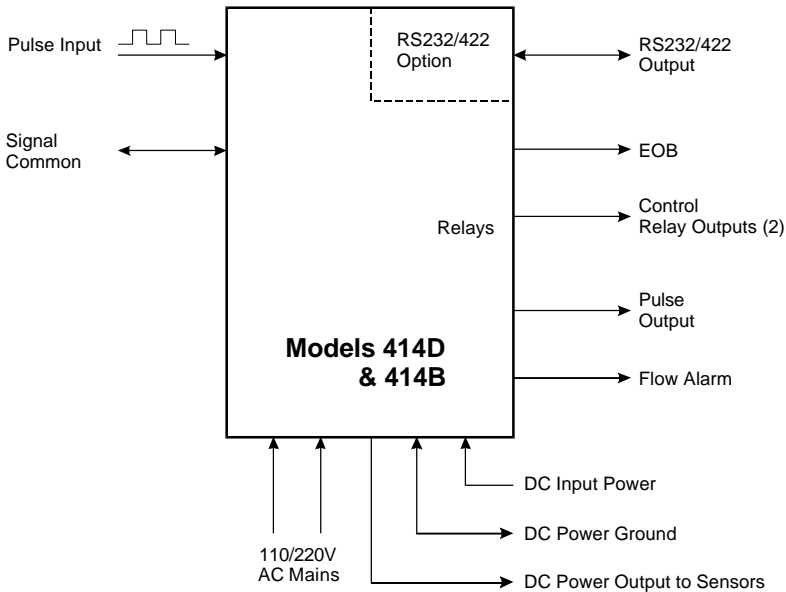

### 3.1 FRONT PANEL OPERATION

The four key operation of the Batch Controller is straightforward.

#### *SETTING THE BATCH QUANTITY*

The Batch quantity is programmed as follows:

<i>Switch Action</i>	<i>Display</i>	<i>Comments</i>
Press BATCH SET	Batch	"Batch" is displayed for one second followed by the batch quantity last entered. The Batch Set LED lights.
	"1" 2345	The most significant digit flashes indicating that it can be changed.
Press $\Delta$	"2" 2345	Pressing the DISPLAY key will increment the digit. (The up arrow on the Display key indicates to increment digit.)
Press $\triangleright$	2 "2" 345	Pressing the RUN key will change digit and enables the next digit to be incremented. (The right arrow on the RUN key indicates to change digit.)
Press BATCH SET	Set	Once the desired number is entered, press the BATCH SET key to return to the Run mode. The Batch Set LED will extinguish.

Once programmed, the Batch quantity will be retained in the non-volatile memory and will not alter until changed by the user.

## 10 Operation

The Batch quantity can only be set while the instrument is in non-operational state such as when the batch is complete, or if the batch process has been interrupted. However, the Batch key can be pressed while in the run state and the Batch quantity checked. All digits will flash to signal the quantity cannot be changed.

### ***STARTING A BATCH***

To start the process the RUN key is pressed. The Run LED will light and the instrument will begin to totalise from zero or, if programmed for the count down mode, the display will decrement from the batch quantity.

The batcher has two output relays and these are energised and de-energised as described in Section 3.2.

### ***STOPPING***

The process can be stopped at any time by pressing the STOP switch. Once the process has been interrupted in this way it can be continued by pressing the RUN switch or the process can be aborted and the instrument reset by pressing the STOP switch a second time.

When the process is interrupted, the STOP LED will flash to prompt the operator to either restart or abort the batch.

### ***RESETTING***

The instrument can be programmed to reset in one of two ways.

- ◆ At the end of a batch, the STOP key must be pressed to reset the Batch Total. If the instrument is programmed to count down, the Batch Total will then revert to the preset quantity. If it is programmed to count up, the Batch Total will clear to zero.
- ◆ If Auto Reset is programmed, the Batch Total will automatically reset when the RUN key is pressed and then commence the next batch.

### ***DISPLAYED INFORMATION***

The display will normally show the Batch Total, which is the total count for the current batch and is reset on each new batch.

The DISPLAY key can be used to display the following additional information:

#### **Rate**

On the first press of the DISPLAY key, the display shows RATE for one second followed by the flowrate.

#### **Accumulated Total**

On the next press of the DISPLAY key, the display shows ACC for one second followed by the actual total. The Accumulated Total cannot be reset during normal operation.

### ***LIMIT ON BATCH SIZE***

To prevent accidental entry of large batch quantities, a maximum batch limit can be programmed during calibration. The operator is then prevented from entering a batch quantity which exceeds this value.

## 12 Operation

### 3.2 BATCH OPERATIONS

The Batch Control functions can be programmed, during Calibration, to operate in one of two ways.

1. At the end of the batch, the STOP key must be pressed to reset the Batch Total. (This must be done before another batch can be started.)

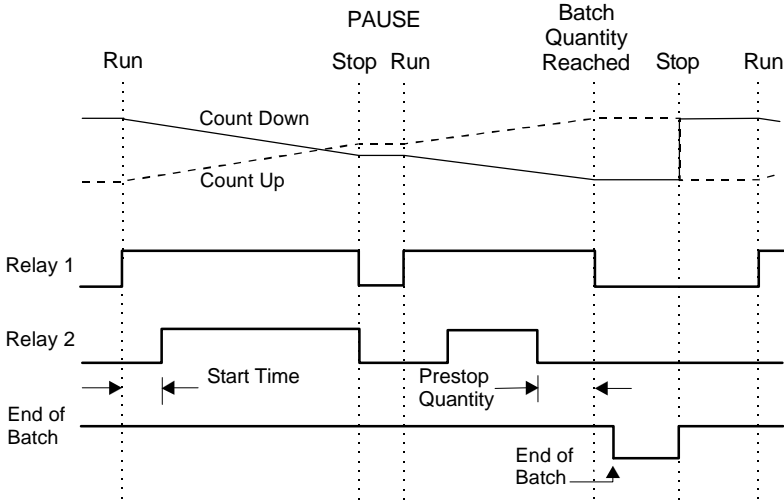

- If Automatic Reset is programmed, a new batch is commenced each time the RUN key is pressed.

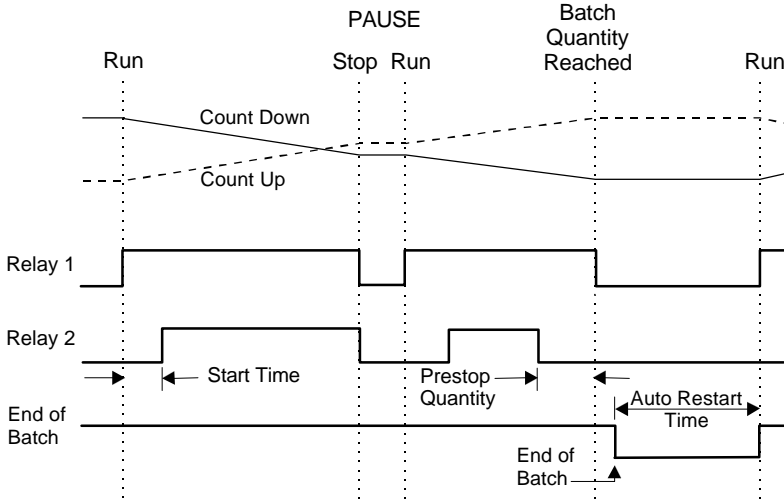

The Batch Controller can also be programmed, during Calibration, to either count up from zero on each batch, or to count down from the preset batch quantity.

## 14 Operation

### 3.2.1 Control Relay Outputs

The two output relays can be set up to control a single valve or a dual valve with slow stop and/or slow start. Alternatively, the second relay can be used to control a pump.

The relay operation is shown on the previous two pages.

A time delay between the Start and the time when relay 2 energises can be programmed to provide a soft startup. The delay can range from 0 (no delay) to 79 minutes and 59 seconds.

A Prestop quantity (ie. the quantity to the end of the batch) can also be programmed to provide a slowdown of flow at the end of the batch, thereby enabling precise quantities to be batched.

The process can be stopped at any time by pressing the STOP key, whereby both relays will immediately de-energise. The process can then be aborted and the batcher reset by pressing the STOP key again, or the process continued by pressing the RUN key.

If the process is continued and the instrument was previously in the slow start or main control phases (ie. not the prestop phase), the timer will be reset and a slow start will occur with a full time delay to ensure a correct start up. The totals will not be reset and the batch quantity will remain unchanged.

### 3.2.2 Signal Timeout

The Signal Timeout period defines a time interval which is used to detect if the flow has stopped. If there is no signal input for a time greater than the Signal Timeout period, the flow is deemed to have stopped. A Signal Timeout period has two functions:

- ◆ To detect the loss of signal midway through a batch when the relays are energised. In this case, the Batcher will enter a Flow Alarm condition and de-energise the relays.
- ◆ After the preset batch quantity has been reached and the relays de-energised, some overrun of flow may occur due to slow valve closure, etc. In this case, the Signal Timeout is used to determine when the flow has ceased and thereby accurately determine the amount of overrun.

It is recommended that Signal Timeout periods are kept fairly short, but long enough such that the period is significantly longer than the time period between successive input pulses from the flowmeter at the minimum flowrate.

The instrument enables the user to program a time interval of up to 99 seconds to detect an absence of signal input. **If the Signal Timeout is set to 0, this function is disabled.**

#### *Flow Alarm*

If the Signal Timeout is set at greater than 0, and loss of signal is detected midway through a batch, a Flow Alarm condition exists and both relays are de-energised. The Flow Alarm condition is maintained until acknowledged by pressing the STOP switch. The alarm condition is also signalled to the operator by the flashing STOP LED. Once acknowledged, process can then be reset via the STOP switch or continued by pressing the RUN key.

With the Model 414D, an open collector output on terminal 7 will also switch "On" whenever the Flow Alarm condition exists (see Section 3.5).

## 16 Operation

### 3.2.3 End of Batch

An End of Batch is defined as being when the Batch Quantity is reached, the flow has stopped and the Signal Timeout period has expired.

If the Signal Timeout is set to zero, the End of Batch is defined as being when the Batch Quantity is reached, regardless of whether the flow has stopped.

The Batch Controller cannot be reset or restarted until the End of Batch and similarly, for an RS232/422/485 interface, data will not be output until the End of Batch has been determined. Consequently, it is strongly recommended that the Signal Timeout period be kept fairly short.

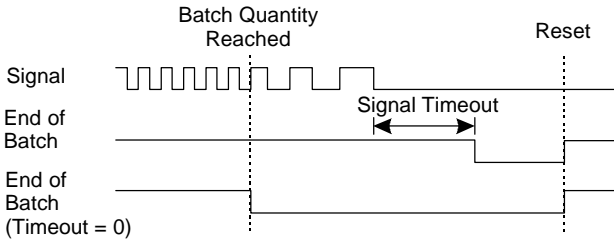

#### *End of Batch Signal*

An End of Batch signal from an open collector transistor is output on terminal 30, if this terminal has been assigned as an End of Batch Signal, and the output is identical to the Output Pulse circuit as shown in Section 3.5.

When reaching the End of Batch, the output transistor is switched on, and will remain in the "on" state until the instrument is reset.

### 3.2.4 Auto Restart

The Batch Controller can be programmed to continually repeat the batch process. This mode of operation is selected during the programming procedure.

The process is started by pressing the RUN key whereby the normal batch operation is commenced. After reaching the End of Batch (see Section 3.2.3), the Batch Controller will then wait for a pre-programmed period before automatically resetting and starting the batch process once again.

The STOP button can be pressed at any time to interrupt the batching process and continued using the RUN key. If, however, the process is to be aborted, the STOP key is again pressed. The Batch Controller is reset and to restart the auto batching process the RUN key is pressed.

## 18 Operation

### 3.2.5 Automatic Overrun Compensation

The Batch Controller can be programmed to automatically compensate for any overrun at the end of a batch.

Typically, this could be due to the slowness of a valve to close or a pump to stop pumping on receiving a signal from the Batch Controller. The result is that the batch quantity will always read higher than the batch quantity set.

The Automatic Overrun Compensation can be enabled or disabled during the Calibration routine and this feature should only be used if the overrun is repeatable. The user is cautioned against using Automatic Overrun Compensation if the overrun is erratic, such as may occur with changing back pressures or sticking valves.

In calculating the amount of overrun to be compensated for, the Batch Controller uses the average overrun on the last three batches.

The overrun is defined as the difference between the batch quantity set by the user and the batch total once the flow has stopped.

With Automatic Overrun Compensation, the **Signal Timeout must be set to a value greater than zero.**

Once the Batch Controller de-energises both relays, the instrument looks for a Signal Timeout, indicating that the maximum interval between pulses has occurred and that the flow must, therefore, have stopped. It then uses the overrun quantity measured during this period and averages this together with the overrun on the last two batches. The resulting value is then subtracted from the next batch.

### 3.3 CALCULATION OF RATE AND TOTAL

#### 3.3.1 Frequency Input

The flowrate,  $R$ , is calculated as follows:

$$R = \frac{f \times H}{S}$$

where  $f$  is the input frequency in Hz.

$H$  is the timebase of rate and is 1 for seconds, 60 for minutes, 3600 for hours and 86,400 for days.

$S$  is the Scaling Factor.

The Scaling Factor,  $S$ , is equal to the K-factor of the flowmeter expressed in pulses per unit volume.

The user programs the Scaling Factor and selects the timebase during the Calibration procedure as detailed in Section 5 of this manual.

## 20 Operation

### 3.3.2 Filtering

Frequency fluctuations caused by pulsating flow through a flowmeter, often makes the Rate impossible to read with any precision. The Batch Controller has a digital filter which will average out these fluctuations and enable the Rate to be read to four digit accuracy. The ability to select a suitable filtering level means that highly accurate and stable readings can be obtained without excessive lag.

The diagram below shows a pulsating signal input together with the effect of filtering.

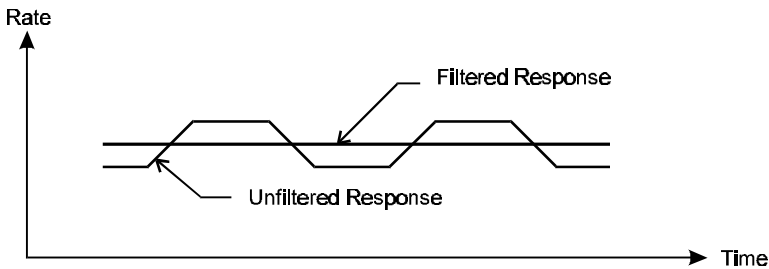

As a guideline to the degree of filtering to be used, the following table shows the response to a step change in input. The value, A, is the filter constant which is programmed during the Calibration routine. The times for the display value to reach 90% and 99% of full swing are given in seconds, for different values of A.

<b>A</b>	<b>90%</b>	<b>99%</b>
1	0	0
2	1	2
4	2	4
6	3	6
10	5	11
15	8	17
20	11	22
25	14	28
35	20	40
45	25	51
60	34	69
75	43	86
90	52	103
99	57	113

Table 1 - Response to a step Input (in seconds).

Note that if A is set to 1 there is no filtering of the input signal.

## 22 Operation

### 3.4 TOTAL CONVERSION

The Total Conversion feature enables the rate to be displayed in one engineering unit (eg. gallons/minute) and the totals to be displayed in another engineering unit (eg. barrels).

The Scaling Factor is always programmed in the unit relating to Rate, and the Total Conversion constant is a division factor which can be used to convert the totals to the different unit. The Total Conversion factor affects the net, accumulated and gross totals and is limited between 0.01 and 2000.

#### For Example

If the Rate is required in gallons per minute:

1. Scaling Factor would be programmed as pulses per gallon.
2. The timebase would be programmed as minutes.

If the Totals are required in barrels:

3. The Total Conversion factor is programmed as 42 (there are 42 gallons in a barrel). All totals, including the Batch Quantity and Batch Total, will now be in barrels.

Some common units are given below together with the Total Conversion constant (TOTCON) which should be programmed.

<u>Rate</u> *	<u>Totals</u>	<u>TOTCON</u>
Gallons (US)/	Barrels (oil)	42.000
Litres/	Kilolitres	1000
ml/	Litres	1000
Mgallons/	Acre-feet	0.32587

\* Units per second, minute, hour or day. The timebase is programmed separately during Calibration.

### 3.5 THE OUTPUT PULSE AND FLOW ALARM (Model 414D Only)

An **OUTPUT PULSE** is available on terminal 10 for driving remote counters and produces a pulse each time the Accumulated Total increments by one digit. For example, if the Accumulated Total has a resolution of 0.01 litres, a pulse is produced each 0.01 litres.

The pulse is a current sinking pulse of approximately 10mSec produced by an open collector transistor. The maximum pulse rate is limited to 49 pulses per second and the resolution on the accumulated total must be set so that the accumulated total increments at less than 49 counts per second.

Note that due to the uneven pulse output spacing on this output, the pulse output cannot be used to drive rate indicators.

The **FLOW ALARM** uses an identical circuit to the Output Pulse, and is on terminal 7.

The Flow Alarm will output an alarm condition if the flow times out during a batch (ie. there is no flow registered for a time greater than the Signal Timeout period, providing the Signal Timeout is greater than 0).

The Flow Alarm output will switch "on" (ie. the signal goes low) whenever an alarm condition exists. The Alarm will switch "off" (ie. the signal goes high) when the alarm is reset by pressing the STOP key.

## 24 Operation

Connection of Output Pulse and Flow Alarm are as follows:

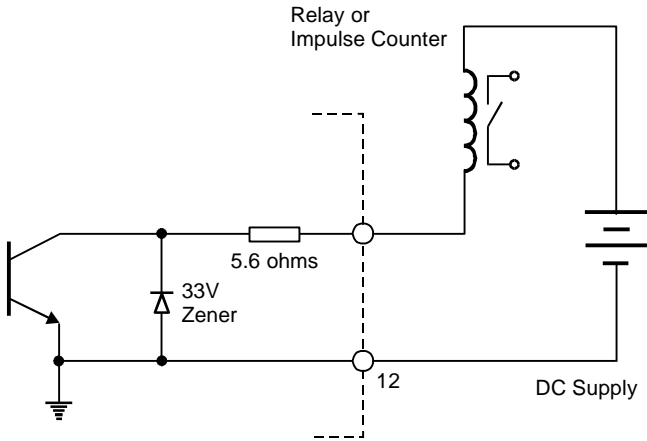

**Driving an External Relay or Impulse Counter**

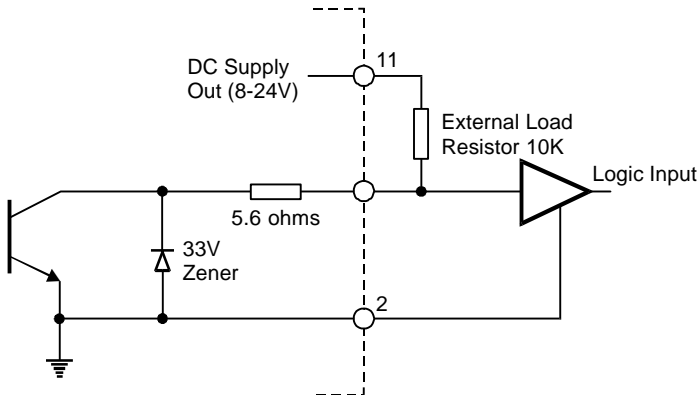

**Driving a Logic Input such as a PLC or Electronic Counter**

# 4. OPTIONS

## 4.1 THE RS232/422/485 INTERFACE OPTION

With this option installed, the circuits for both the RS232 and RS422/485 are provided as standard. They can be used to interface to both printers and computers and a number of standard protocols are built into the instrument.

### 4.1.1 Hardware

The following diagram provides an overview of the RS232/RS422/RS485 communications hardware. All three interfaces are available on the rear terminal strips and the user can select either one by making the appropriate connections.

The RS232 interface is primarily used with printers or for simple communication with a computer over a short distance. The RS422 and RS485 interfaces are used for communication over a long distance or in applications requiring multipoint communication.

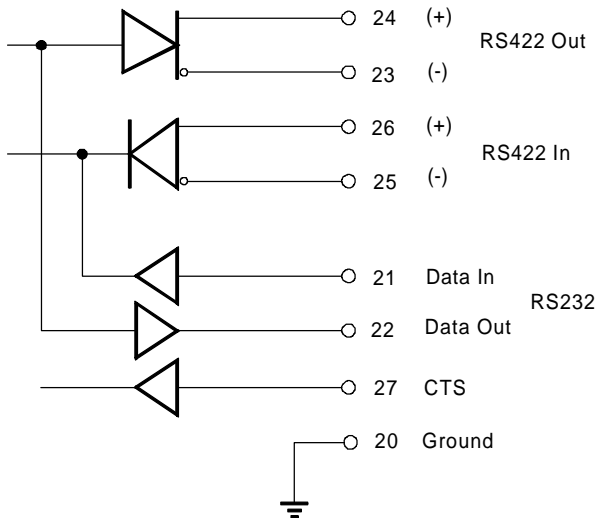

## 26 Options

### 4.1.2 Multipoint Communication

Multipoint Communication is a system whereby a number of instruments can be addressed over a dual twisted pair interface. Up to 32 instruments can be connected to a common bus using the RS422 and RS485 interfaces as shown below.

To convert the RS422 interface to an RS485 interface, the RS422 (-) Data In Terminal must be connected to the RS422 (-) Data Out Terminal and the RS422 (+) Data In Terminal must be connected to the RS422 (+) Data Out Terminal. These connections will convert the RS422 4 wire interface to the RS485 2 wire interface, as shown in figure 2.

Each instrument can be programmed with a unique address which is used by the Master Controller (ie. IBM/PC) to identify each instrument. The Controller will send the address down the line and will alert the relevant instrument. Subsequent software protocol will control the flow of data between the Controller and the Instrument.

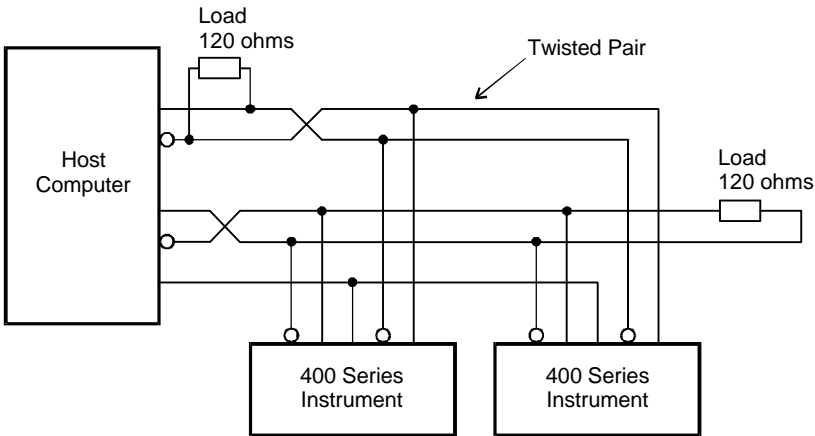

*Figure 1 RS422 Interface*

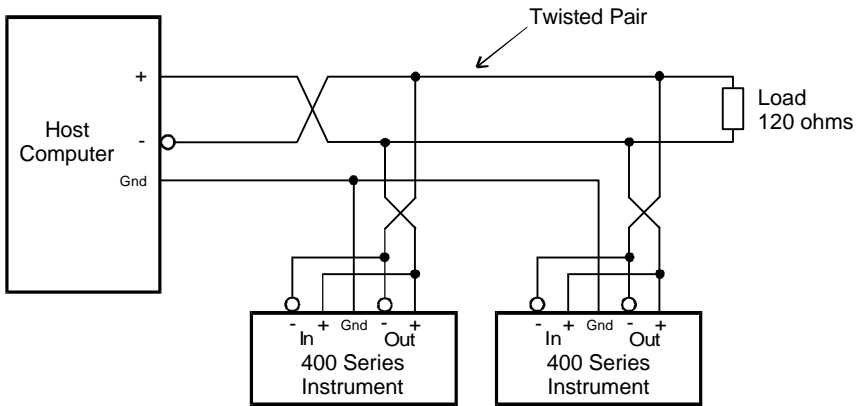

*Figure 2 RS485 Interface*

## 28 Options

### 4.1.3 Communication Protocol

The Model 414D/B has a real time clock and enables the time and date to be set and printed on tickets. The date format can be European (days/months/years) or USA (months/days/years), while the time is on a 24 hour clock.

Note that the clock will only retain its time for 3 days minimum if there is no power connected to the instrument. After this period, the clock may need to be reset.

The baudrate, parity and word length can be programmed during calibration and the user must ensure that these correspond to the setting on the printer or computer with which the 414D/B is communicating.

The software protocols can be selected during Calibration to provide standard interfaces to a number of printers and computers. Since other interfaces will continue to be added, the user should consult the manual "*The RS232/422/485 Communications Option for the 400 Series, Version 2*", for the latest protocols and printer drivers.

#### ***Printer***

A ticket is printed each time a batch is complete. Protocols are provided to drive the following printers:

1. Standard Computer Printer  
(Note that the printer must have an RS232 Serial Interface)
2. EPSON CTM290 Slip Printer
3. Contrec Model 624
4. EPSON TM290-2 Slip Printer
5. Contrec Model 632-2
6. Syntest SP-210

The tickets can also be printed with a number of different units, including litres and gallons. The units are selectable from a pre-programmed list.

A CTS input is provided, and will prevent the instrument from transmitting any further characters to a printer if the printer buffer is full. The CTS input is usually connected to the "Data Buffer Full" output from the printer.

If the printer buffer is large enough to handle the messages output from the Batch Controller, then this input need not be used and can be left unconnected.

### *Computer*

The instrument receives and transmits messages in ASCII, with all command strings to the instrument terminated by a carriage return while replies from the instrument are terminated with a carriage return and a line feed.

Xon/Xoff protocol is also supported, and the instrument will automatically determine if the message sent by the host computer is preceded by an Xoff character. If it does recognise an Xoff as the first character of a command string, the instrument will automatically switch to Xoff/Xon protocol, and begin & end all messages with Xoff and Xon characters respectively. Xoff/Xon protocol is only available when the RS232 interface is selected.

During Calibration, the instrument can be programmed to operate in a full duplex or half duplex transmission mode. In full duplex mode, all commands sent to the instrument will be echoed back to the host computer. In half duplex, the commands are not echoed.

For more information on the computer interface please consult the manual *"The RS232/422/485 Communications Option for the 400 Series, Version 2"*.

# 5. CALIBRATION

The Calibration routine enables the Setup Parameters to be programmed, as well as enabling the input signals to be checked.

The calibration routine can be entered in two ways:

1. By connecting a wire link (or switch) to the rear terminal strip across terminals 1 and 2 or,
2. By pressing the STOP key and while still holding, press the DISPLAY key. Both keys must then be held for approximately 6 seconds. This second method of access can be disabled during the calibration so that it is only possible to enter the calibration routine via the link across terminals 1 and 2.

The key switch actions during Calibration are as follows:

<b>RUN</b>	will change a flashing digit, to the next digit.
<b>DISPLAY</b>	will increment a flashing digit or change a parameter selection.
<b>BATCH SET</b>	will reset a flashing digit to zero.
<b>STOP</b>	will step through the program sequences.

Note that the arrows in the RUN and DISPLAY key switches indicate that these switches can be used to change and increment digits respectively.

In stepping through the program sequence, the Parameter Description is always displayed first, followed by actual value or parameter. When a value or parameter can be changed, it is always shown as flashing, and the LED's in the switch panels are lit if that key switch can be used to change a value.

On first entering the Calibration routine, the display will show:

<b>CAL</b>	Setup Program parameters (see Section 5.1)
<b>Batch</b>	Enter Batch parameters (see Section 5.2)
<b>Option</b>	Option - if installed (see Section 5.3)
<b>Test</b>	Check Input Signals (see Section 5.4)
<b>End</b>	Exit to Normal Operation

The user can toggle between these modes using the DISPLAY switch and by using the STOP switch, select the appropriate mode.

To exit Calibration, step through the Setup program, Batch program or Test program until the end, and press the STOP switch when **End** is displayed, (ensure the calibration link is not connected).

## 32 Calibration

### 5.1 PROGRAMMING THE SETUP PARAMETERS

<i>Step</i>	<i>Display</i>	<i>Description</i>	<i>Text Ref</i>
1	<b>CAL</b>	Select the Calibrate mode to setup program parameters.	
	<b>BATCH</b>	Select Batch to enter Batch Setup parameters.	5.2
	<b>OPTION</b>	Option (if installed).	5.3
	<b>TEST</b>	Select the test mode to check input signals.	5.4
	<b>END</b>	Exit to normal operation.	

The following steps are displayed if CAL is selected.

2	<b>RESTOT</b>	Reset all <u>totals</u> to zero. To reset all totals (resettable and accumulated) press the BATCH SET key once.	
3	<b>SCALE</b>	Scaling Factor.	
	<b>Fact</b>	Enter the <u>Scaling factor</u> (K-factor) of the flowmeter.	3.3.1
4	<b>F dPt</b>	Number of decimal points with which the <u>Rate</u> is to be displayed between 0 to 0.00000.	
5	<b>t.base</b>	The <u>Timebase</u> with which the Rate is calculated must be entered as:	
	<b>60secs</b>	units/min	
	<b>hours</b>	units/hour	
	<b>days</b>	units/day	
	<b>secs</b>	units/second	
6	<b>FILTER</b>	The <u>filter constant</u> for filtering the rate display.	3.3.2
	<b>1</b>	No filtering.	
	<b>to</b>		
	<b>99</b>	Very heavy filtering.	

<i>Step</i>	<i>Display</i>	<i>Description</i>	<i>Text Ref</i>
7	<b>TOTCON</b>	A <u>division factor</u> to convert the totals to different units from those used for rate (ie.gallons/min and barrels).	3.4
	<b>I</b>	Rate and totals have the same engineering units.	
	<b>x.xxxx</b>	Other factors can be programmed between 0.01 and 2000.	
8	<b>t.dPt</b>	Number of decimal points with which the resettable total is displayed between 0 to 0.000.	
9	<b>A.dPt</b>	Number of decimal points with which the <u>Accumulated</u> (non resettable) total is displayed between 0 to 0.000.	
10	<b>ACCESS</b>	Enable access to calibration routine via the front keyboard only.	
	<b>Front</b>	Enable access via front keyboard.	
	<b>No Acc</b>	Disable access via front keyboard.	

## 5.2 ENTERING THE BATCH PARAMETERS

<i>Step</i>	<i>Display</i>	<i>Description</i>	<i>Text Ref</i>
1	<b>BATCH</b>	Enter Batch Parameters.	
	<b>OPTION</b>	Option (if installed)	5.3
	<b>TEST</b>	Check Input Signals.	5.4
	<b>END</b>	Exit to normal operation.	
	<b>CAL</b>	Program Setup Parameters.	5.1

*The following steps are displayed if BATCH is selected.*

2	<b>BATCH L</b> <b>xxxxxx</b>	Maximum Batch Size which can be entered. Set to 0 if no limit on batch size.	3.2
3	<b>AUTO S</b>	Automatic <u>restart</u> feature.	
	<b>Off</b>	Disable.	
	<b>On</b>	Enable.	
	<b>xx:xx</b>	If enabled, automatically restarts the batch xx:xx (mins:sec) after the end of the last batch.	3.2.4
4	<b>START. T</b>	<u>Slow start</u> time.	
	<b>xx:xx</b>	Time, in (minutes:seconds), when Relay 2 will energise once the batch has started.	3.2
5	<b>PREST</b>	<u>Prestop Quantity</u> .	
	<b>xxxx</b>	Quantity at which Relay 2 will de-energise before the end of the batch. (eg. If the batch quantity is 100 litres and Prest is 2 litres, relay 2 will de-energise after 98 litres.)	3.2

<i>Step</i>	<i>Display</i>	<i>Description</i>	<i>Text Ref</i>
6	<b>COUNT</b>	The <u>Batch Total</u> counts Up or Down.	
	<i>dn</i>	Count down from the batch quantity.	3.2
	<i>up</i>	Count up from zero.	
7	<b>T OUT</b>	The <u>Signal Timeout</u> in seconds. (Setting to 00 disables this feature.)	3.2.2
8	<b>AOC</b>	Automatic <u>Overrun Compensation</u> . Note that the Signal Timeout must be greater than 0 (ie. enabled) for this feature to work.	3.2.5
	<i>En</i>	Enable.	
	<i>Dis</i>	Disable.	
9	<b>AUTO R</b>	<u>Auto Reset</u> (not displayed if Auto Restart is programmed - Step 3 above).	
	<i>Off</i>	Batch Total must be manually reset before starting the next batch.	
	<i>On</i>	The Batch can be automatically reset and started by pressing only the RUN key.	3.2

### 5.3 PROGRAMMING OPTIONS

<i>Step</i>	<i>Display</i>	<i>Description</i>	<i>Text Ref</i>
1	<b>OPTIONS</b>	Options (if installed).	
	<i>Test</i>	Check the Input Signals.	5.4
	<i>End</i>	Exit to normal operation.	
	<i>CAL</i>	Program Setup Parameters.	5.1
	<i>Batch</i>	Set Batch Parameters.	5.2

*If the RS232/422/485 option is installed, the following will be displayed:*

2	<b>DF</b>	Date Format.	4.1
	<b>Eur</b>	European (ie. days/months/years).	
	<b>USA</b>	USA (ie. months/days/years).	
3	<b>Date</b>	Enter date as:	4.1
	<b>xx:xx:xx</b>	Years:Months:Days.	
4	<b>HOUR</b>	Enter time as a 24 hour clock.	
	<b>xx:xx</b>	Hours:Minutes.	
5	<b>BAUD</b>	Baudrate	
	<b>xxx</b>	300, 600, 1200, 2400, 4800 and 9600.	
6	<b>DATA</b>	Word length.	
	<b>7</b>	7 bits.	
	<b>8</b>	8 bits.	
7	<b>PARITY</b>	Parity.	
	<b>NP</b>	No Parity.	
	<b>OP</b>	Odd Parity.	
	<b>EP</b>	Even Parity.	
8	<b>SIGNAL</b>	Signal Type.	
	<b>rs232</b>	RS232.	
	<b>rs422</b>	RS422/RS485.	

<i>Step</i>	<i>Display</i>	<i>Description</i>	<i>Text Ref</i>
9	<b>ID NO</b> <b>0</b> <b>1 - 99</b>	Unit Identification Number. None. Id number.	
10	<b>P TYPE xx</b>  <b>00</b> <b>01</b> <b>02</b> <b>03</b> <b>04</b> <b>05</b>  <b>20</b>	Printer/Computer Type.  Standard Computer Printer. EPSON CTM 290 Slip Printer. Contrec Model 624 Printer. EPSON TM 290-2 Slip Printer. Contrec Model 632-2 Printer. Syntest SP-210 Printer.  Computer.	

*If a Printer Protocol is selected, the following message is displayed:*

10	<b>UNIT xx</b>  <b>00</b> <b>01</b> <b>02</b> <b>03</b> <b>04</b> <b>05</b> <b>06</b> <b>07</b>	Units of measurement printed.  None. Litres (Ltrs). Gallons (Gals). Barrels (bbls). Pounds (lbs). Grams (gms). Kilograms (kgs). Tons (tons).
----	--	---

*If a Computer Protocol is selected, the following message is displayed:*

10	<b>ECHO</b> <b>On</b> <b>Off</b>	ECHO Command. Echo (Full Duplex). No Echo (Half Duplex).
----	--	--

## 5.4 CHECKING THE INPUT SIGNAL

<i>Step</i>	<i>Display</i>	<i>Description</i>	<i>Text Ref</i>
1	<b>TEST</b>	Check the Input Signals.	
	<b>OPTIONS</b>	Options (if installed).	5.3
	<b>CAL</b>	Program Setup Parameters.	5.1
	<b>BATCH</b>	Set Batch Parameters.	5.2
	<b>END</b>	Exit to normal operation.	

The following steps are displayed if **TEST** is selected.

- |   |                |  |
|---|----------------|--|
| 2 | <b>Sr x.xx</b> | Software revision number.                                |
| 3 | <b>Freq</b>    | Displayed for 1 second followed by the actual frequency. |
|   | <b>xxxx.x</b>  | Frequency in Hz.   |

*If the RS232/422/485 option is installed, the display will then show:*

- |   |                 |                         |
|---|-----------------|-------------------------|
| 4 | <b>CLOC</b>     | Clock.                  |
|   | <b>xx:xx:xx</b> | Time in Hours:Mins:Sec. |

# 6. INPUT CIRCUITS

This section covers the connection of flowmeter signals for:

- ◆ Model 414D      Batch Controller with input signal conditioning card.
- ◆ Model 414B      Batch Controller with a basic signal input capability.

Both the Model 414D and 414B have a regulated output which can be used to power sensors. A trimpot on the rear of the instrument allows the voltage to be adjusted in the range of 8-24 Volts and the output can supply a maximum of 50mA.

## 6.1 INPUT CIRCUIT FOR THE MODEL 414D

The Model 414D has an input conditioning card which will accept signals from most pulse or frequency producing flowmeters. An 8 position DIL switch on the rear panel enables the input circuit to be configured for different signal types.

The input will interface directly to:

- Turbine Flowmeters
- Open Collector Outputs
- Reed Switches
- Logic Signals
- Two Wire Proximity Switches

The following pages give examples of interconnection to various signal outputs, and a circuit diagram of the input is also provided.

## 40 Input Circuits

### *Switch Settings*

The following switch settings are recommended for different input signal types.

Input Signal Type	Input Terminals		Switch Settings							
	CHI		1	2	3	4	5	6	7	8
a. Logic Signal, CMOS, Pulse	+	-	off	off	off	off	on	off	off	off
b. Open Collector or Reed switch	9	8	off	off	off	off	on	off	on	off
c. Namur Proximity (set DC out to 8 volts)	11	9	off	off	on	on	on	off	off	off
d. Switch or Reed Switch with debounce circuit (200Hz max)	9	8	off	off	off	off	on	off	on	on
e. Coil (20mV P-P minimum)	9	8	off	on	off	off	off	off	off	off
f. Coil (low impedance) 22mV pp minimum	9	8	on	on	off	off	off	off	off	off

### *General Specification*

Switching Threshold: 2.5 Volts (except for input type c, e and f)

Maximum Input Voltage: 50V peak

Input Impedance

Input type a: 100K

Input types b & d: 10K

Input type c: 1K

Input type e: 100K

Input type f: 2.4K

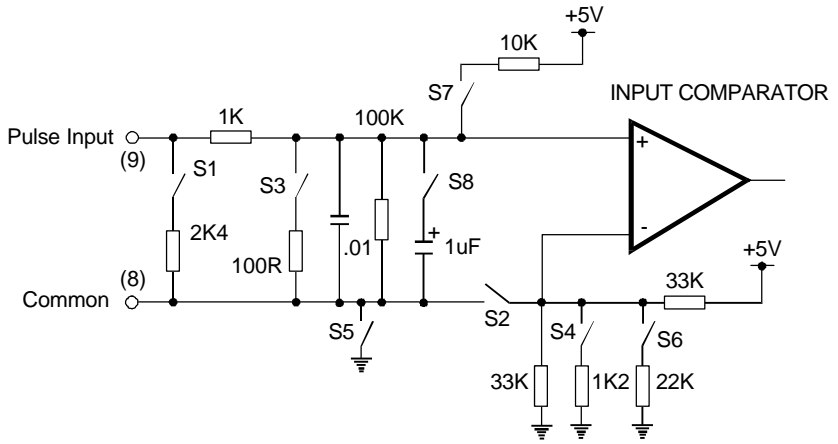

The Frequency Input Circuits

## 42 Input Circuits

### 1. Squarewave, CMOS or Pulse

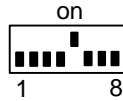
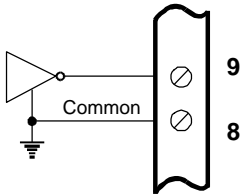

**Model 414D**

eg. vortex, preamplifiers  
or magnetic flowmeters

### 2. Open-Collector

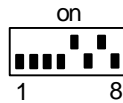
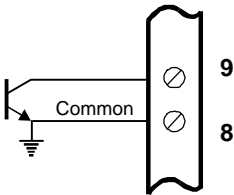

**Model 414D**

eg. hall effect  
sensors

### 3. Reed Switch

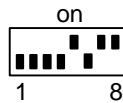
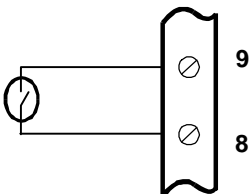

**Model 414D**

eg. positive displacement  
flowmeters with reed switch

### 4. Coils

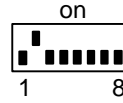
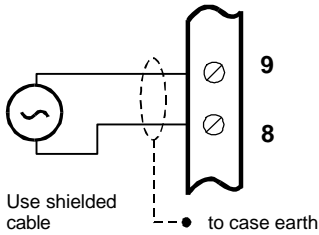

Model 414D

eg. millivolt signal from a turbine flowmeter (single input only)

### 5. Namur Proximity Switch

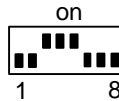
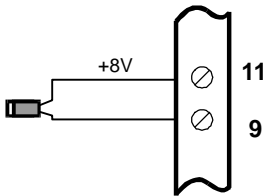

Model 414D

eg. positive displacement flowmeters with 2 wire proximity switch outputs

### 6. Opto-Sensors

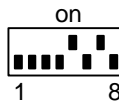
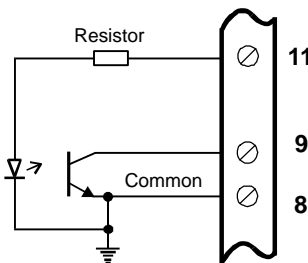

Model 414D

eg. preamplifiers and opto-sensors

Note that the current limiting resistor may be required. See the flowmeter manufacturer's data.

### 6.2 INPUT CIRCUIT FOR THE MODEL 414B

The Model 414B will accept basic squarewave, pulse or open collector output signals, but is not able to read mV signals from coils, nor two wire proximity switch outputs. The Model 414B has limited input filtering and signal levels must switch between the levels specified below.

For open collector outputs, an internal 10K resistor will act as a load. However, the user must still ensure that the resulting signal will switch about the specified levels.

#### *General Specification*

Signal Types: Squarewave, Pulse or Open Collector.

Signal Level: The "low" signal level must be  $< 1.5\text{Volts}$ .

The "high" signal level must be  $> 3.0\text{Volts}$  and must not exceed 30 Volts.

The input circuit for the Model 414B and installation examples are shown on the following pages.

**The Input Circuit**

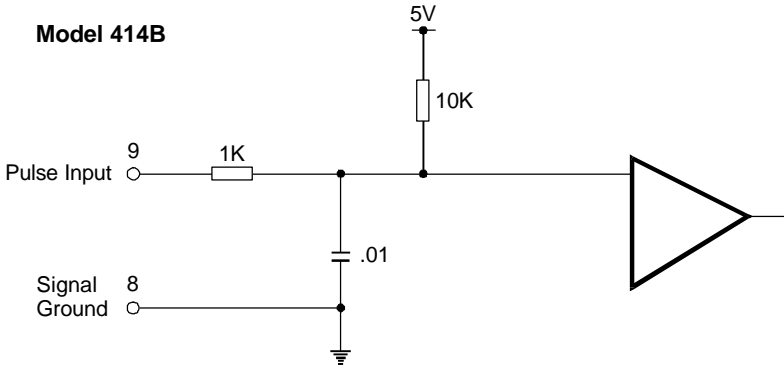

**1. Squarewave or Pulse Inputs**

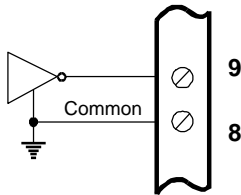

**Model 414B**

eg. vortex or magnetic flowmeters

**2. Open-Collector Inputs**

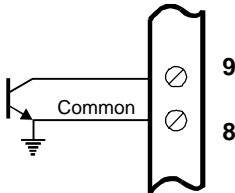

**Model 414B**

eg. hall effect sensors

## 46 Input Circuits

### 3. Opto-Sensors

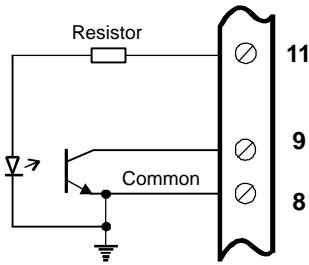

#### Model 414B

Note that the current limiting resistor may be required. See the flowmeter manufacturer's data.

### 4. Reed Switch

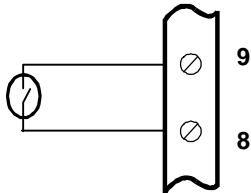

#### Model 414B

eg. positive displacement flowmeters

## 6.3 REMOTE SWITCHES

Remote push-buttons can be connected to the Models 414D and 414B to duplicate the switches on the front panel. On the Model 414D, all four switches are taken to the rear terminals, while only the RUN and STOP switches are available on the Model 414B.

The switches are wired as follows:

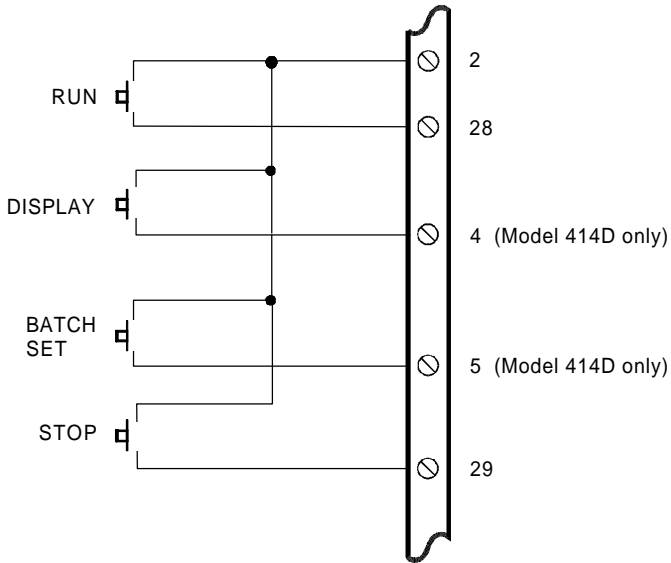

# 7. INSTALLATION

## 7.1 GENERAL

Terminal designations for the Model 414D and 414B Batch Controllers are given on the following pages. The cutout hole in the panel should be 5.5" (139mm) wide x 2.6" (67mm) high. Two side clips are supplied to secure the instruments into panel.

A case earthing point is provided via an earth lug on the side of the case. Note that this earthing point is for the case only and there is complete electrical isolation between this point and all electronic circuits. For EMC purposes, or when the instrument is connected to mains, this point must be connected to a good earth using a multi-stranded, braided wire or strap. All relay outputs are totally isolated from the case and from the internal circuitry.

The two output relays are changeover relays and both the "normally open" and the "normally closed" terminals are available on the rear terminal strips. All relay outputs are totally isolated from the case and from the internal circuitry.

A Supply Output voltage is provided to power sensors. This output will provide a regulated voltage of 8 to 24 volts and the voltage is adjustable by means of the potentiometer on the rear panel. Maximum current is 50mA and the instrument comes with the voltage factory set at 24 Volts. When the instrument is powered from a DC power source, the maximum output voltage on the Supply Output is the DC Input Voltage less 3.5 volts.

The instrument will operate from either 12 - 28 volts DC or from the mains. The mains voltage is factory set to either 95 - 135 VAC (110 VAC nominal) or 190 - 260 VAC (220 VAC nominal). An internal mains transformer provides full isolation between the mains and the electronic circuits.

The DC Ground terminal 12 provides a common ground for the 12 - 28 Volt power input, the 8 - 24 Volt output, the pulse output and End of Batch output.

It is good practice to use shielded cable for all signal connections to the Model 414. Care must be taken to separate signal cables from power cables so as to minimise interference.

Overall shields should be connected to the case earth at the instrument end only. This connection should be as short as possible and connected to the earthing lug on the side of the case.

In order to comply with the requirements for Electromagnetic Compatibility as per EMC-Directive 89/336/EEC of the Council of European Community, this wiring practice is mandatory.

Although it is also possible to connect shields to the signal ground (terminal 2) this is not in accordance with EMC directives.

### ***RC Networks for Interference Suppression***

When driving highly inductive loads with the relay outputs, it is recommended that RC suppression networks (often called "Snubbers") are used for two reasons:

- ◆ To limit the amount of electrical noise caused by arcing across the contacts which may, in extreme cases, cause the microprocessor to act erratically.
- ◆ To protect the relay contacts against premature wear through pitting.

RC suppression networks consist of a capacitor and series resistor and are commonly available in the electrical industry. The values of R and C are dependent entirely on the load. However, if the user is unsure of the type of snubber to use, values of 0.25 $\mu$ F and 100ohms will usually suffice. Note that only mains approved RC suppression networks should be used.

The basic principle of operation is that the capacitor prevent a series of sparks arcing across the contact as the contact breaks. The series resistor limits the current through the contact when the contact first makes.

## 7.2 WIRING DESIGNATIONS FOR THE 414D & 414B

<i>Terminal</i>	<i>Model 414D</i>	<i>Model 414B</i>
1	Calibration Link	Calibration Link
2	Signal Ground	Signal Ground
3	Not To Be Used	Not To Be Used
4	Remote Display Switch	Not To Be Used
5	Remote Batch Set Switch	Not To Be Used
6	Not To Be Used	Not To Be Used
7	Flow Alarm	Not To Be Used
8	Flow Common (-)	Flow Common (-)
9	Flow Pulse Input	Flow Pulse Input
10	Pulse Out	Not To Be Used
11	DC Power Out (8-24 VDC)	DC Power Out (8-24 VDC)
12	DC Ground	DC Ground
13	DC Power Input	DC Power Input
14	Not To Be Used	Not To Be Used

<i>Terminal</i>	<i>RS232/422/485 Option</i>
20	RS232 Signal Ground
21	RS232 Data In
22	RS232 Data Out
23	RS422/485 (-) Data Out
24	RS422/485 (+) Data Out
25	RS422/485 (-) Data In
26	RS422/485 (+) Data In
27	RS232 CTS

<i>Terminal</i>	<i>Relay Output &amp; Switches</i>
28	Remote RUN Switch
29	Remote STOP Switch
30	End of Batch/Pump Control Signal
31	Relay 2 - Normally Open
32	Relay 2 - Normally Closed
33	Relay 2 - Common
34	Relay 1 - Normally Open
35	Relay 1 - Normally Closed
36	Relay 1 - Common

# 8. TROUBLE SHOOTING

## ***Batcher does not reset.***

The Signal Timeout has been set to an excessively long period and has not timed out at the end of the last batch.

## ***Batch will not start or relay 1 will not close.***

Ensure that the instrument has not timed out as controlled by the Signal Timeout and that a Flow Alarm condition does not prevail. Pressing the Stop switch will cancel this condition. Check for a fault on the flow input before restarting.

## ***Batcher stops midway through a batch.***

This could be due to the Signal Timeout having timed out. Check for a fault in the system. Ensure that the Signal Timeout period is significantly longer than the period between pulses from the flowmeter at the minimum flowrate.

## ***No display.***

Check power to the instrument.

## ***All 88888888 displayed.***

The Batcher will display all eights on power up for 4 seconds as a display test. If it continues to display all eights after this period, this is symptomatic of the power supply voltage being low. Check the power input voltage.

## 52 Trouble Shooting

### *Not counting.*

If the Batcher does not count with the flowmeter connected and flow passing through it, first check the connections and then ensure the DIL switches (Model 414D only) on the rear of the instrument are set as per Section 6.

It is possible to manually test the input circuit of the Batcher by setting the input configuration for a Reed Switch (see Section 6) and pulsing across the signal (+) and (-) with a wire link. When doing this, the scaling factor should be set to 1 and the resolution to whole numbers.

### *Counting erratically.*

This can be caused by two factors:

- setting the input circuit incorrectly,
- lack of shielding on the input.

Shield the input signal with the shield earthed at the Batch Controller only.

### *Instrument acting erratically.*

Erratic operation can be the result of severe electrical interference. Considerable attention has been given to designing the Batch Controller to withstand electrical interference.

However, in extreme cases, loads may be encountered which are exceptionally inductive and may require additional protection. One measure is to use an RC Suppression Network as described in Section 7.

Another remedy for this problem is to use an isolating relay to switch the load, and use the Batcher to drive the isolating relay. The isolating relay should be mounted away from the Batcher and from signal wiring.

*No end of batch, pulse output or flow alarm.*

This fault is usually caused by lack of a pullup resistor or load on the output. The outputs themselves have no internal pullups and rely on an external load.

## **8.1    ERROR CODES**

The instrument has extensive self test facilities and will display an error code if it detects an invalid condition. If the instrument displays an error code other than those listed below, please contact the factory.

Error codes are displayed as "Err 12" and a list of commonly encountered codes are given below:

### ***Error Codes***

#### ***Input Errors***

- 11        Invalid input configuration programmed.
- 13        Signal Timeout (see Section 3.2.2).
- 14        Communications Input error (RS232/422/485 Interface).

#### ***Output Errors***

- 21        Invalid output configuration.
- 22        Communications error - Baud rate not set.
- 23        Communications error - Printer fault.

#### ***Calibration Errors***

- 30        Zero Value not Allowed.
- 33        Invalid Printer Type.
- 34        Invalid Volume Units selected.

# Index

## A

Access, 33  
 Accumulated Total, 11  
 Auto Reset, 10  
 Auto Restart, 17  
 Automatic Overrun  
 Compensation, 18

## B

Backlite, 5  
 Batch Limit, 11  
 Batch Set, 9  
 Battery Backup, 8  
 Baudrate, 28

## C

Calibration, 30  
 Communication  
 Protocol, 28  
 Computer, 29  
 Conformal Coating, 5  
 Control Functions, 12  
 Control Relay, 14  
 Count Down, 10  
 Count Up, 10  
 Cutout, 6

## D

Date, 28  
 DC Input Voltage, 48  
 Decimal Points, 32  
 Dimensions, 6  
 Display Key, 11  
 Displayed  
 Information, 11

## E

Earth Lug, 48  
 Earthing Point, 48  
 End of Batch, 16  
 Error Codes, 54

## F

Filtering, 20  
 Flow Alarm, 15  
 Frequency Input, 19  
 Frequency Range, 6  
 Front Panel Operation, 9

## G

Ground, 48

## I

Input Circuits, 41  
 Input Impedance, 40  
 Installation, 48  
 Interference, 49  
 Introduction, 3  
 Isolation, 48

## K

K-factor, 19  
 Key Operation, 9

## L

Limit on Batch, 11  
 Logic Signals, 39  
 Loss of Signal, 15

## M

Mains, 48  
 Mains Voltage, 48  
 Model Number, 5

Multipoint  
 Communication, 26

## N

Namur Sensors, 39  
 Non-volatile Memory, 8

## O

Open Collector  
 Outputs, 39  
 Operating  
 Temperature, 6  
 Operation, 8  
 Options, 25  
 Output Pulse, 23  
 Output Relays, 14  
 Overrun, 18

## P

Parity, 28  
 Power Requirements, 6  
 Prestop, 14  
 Printer, 28  
 Pulse Output, 7, 23  
 Pulse Width, 7

## R

Rate, 11  
 Reed Switches, 39  
 Remote Counters, 23  
 Remote Push-buttons, 47  
 Resetting, 10  
 Response, 20  
 RS232/422/485  
 Interface, 25  
 Run Key, 9

## S

Scaling Range, 6

Setting the Batch, 9  
Setup Parameters, 3  
Signal Timeout, 15  
Slow Start, 14  
Slow Stop, 14  
Specification, 6  
Starting, 10  
Stop Key, 14  
Stopping, 10  
Switch Settings, 40  
Switching Current, 6  
Switching Power, 6  
Switching Threshold, 40

**T**

Terminal, 50  
Ticket, 28  
Time Clock, 28  
Time Delay, 14  
Timebase, 19  
Total Conversion, 22  
Transducer Supply, 6  
Trouble Shooting, 51  
Turbine Flowmeters, 39

**W**

Wiring Designations, 50