

# Model 505 Flow Computer

## Operation Manual

### Application LM01

Single Tank Level Monitor  
for  
Analog Level Sensors



17 June 2017

## **Model 505 Flow Computer - Operation Manual**

© Contrec Limited 2017

The instructions given herein cover the general description, installation, operation and maintenance of the subject equipment. Contrec Limited. reserves the right, without prior notice, to make engineering refinements that may not be reflected in this manual.

Should any questions arise which cannot be answered specifically by this manual, they should be directed to Contrec Limited for further detailed information and technical assistance.

Contrec Limited will not accept any liability for either direct or consequential damages resulting from the use or misapplication of the contents of this manual.

Part of the software embedded in this product is eCos - Embedded Configurable Operating System, a trademark of Red Hat. Portions created by Red Hat are Copyright © 1998, 1999, 2000 Red Hat, Inc. (<http://www.redhat.com>). All rights reserved

The software in this product was in part provided by Red Hat and any express or implied warranties, including, but not limited to, the implied warranties of merchantability and fitness for a particular purpose are disclaimed. In no event shall the author be liable for any direct, indirect, incidental, special, exemplary, or consequential damages (including, but not limited to, procurement of substitute goods or services; loss of use, data, or profits; or business interruption) however caused and on any theory of liability, whether in contract, strict liability, or tort (including negligence or otherwise) arising in any way out of the use of this software, even if advised of the possibility of such damage.

### **Contrec Limited**

Riverside, Canal Road, Sowerby Bridge,  
West Yorkshire HX6 2AY UNITED KINGDOM  
Tel: +44 1422 829944 Fax: +44 1422 829945  
Email: [sales@contrec.co.uk](mailto:sales@contrec.co.uk)

**Website: [www.contrec.co.uk](http://www.contrec.co.uk)**

### **Contrec Systems Pty Ltd**

5 Norfolk Avenue Ringwood, Melbourne 3134 AUSTRALIA  
Tel: +61 4 413 505 114  
Email: [info@contrec.com.au](mailto:info@contrec.com.au)

### **Contrec - USA, LLC**

916 Belcher Drive Pelham AL 35124 USA  
Tel: +1 (205) 685 3000 Fax: +1 (205) 685 3001  
Email: [contrec@contrec-usa.com](mailto:contrec@contrec-usa.com)



**Publication No: 505-LM01-OM - 17 June 2017**



# Safety Notice

**The information in this safety notice is for the prevention of injury to personnel and damage to the instrument.**

**The manufacturer assumes no liability for injury or damage caused by misuse of the instrument or for modifications made to the instrument.**

## **Qualified Personnel**

The instrument must be installed, operated and serviced by persons who have been properly trained and authorised. Personnel must read and understand this manual prior to installation and operation of the instrument.

## **Static Hazard**

The 500 series flow computer uses high speed CMOS circuitry which is sensitive to static damage. The user should observe accepted safety practices for handling electronic devices, especially during servicing. Once the unit is installed, grounded and interconnected, the chances of static damage are greatly reduced.

## **Voltage Hazard**

Before connecting power to the instrument, ensure that the supply voltage for the AC or DC input is suitable. The AC voltage rating is as stated on the instrument rating plate. Personnel should take all due care to avoid electric shock. For safe operation it is essential to connect a mains safety earth to the A.C. power inlet. Do not operate at altitudes above 2000m.

## **Welding Hazard**

Do not perform electric welding in close proximity to the instrument or its interconnecting cables. If welding in these areas must be performed, disconnect all cables from the instrument. Failure to do so may result in damage to the unit.

## **Moisture Hazard**

To avoid electrical faults and corrosion of the instrument, do not allow moisture to remain in contact with the instrument.

## **Disconnection Device**

When powered from a mains supply this unit requires the provision of a suitable mains isolation device to be accessible near to the installed instrument.



# Contents

---

## 1 Introduction

Overview	1
Calculations	2
Displayed Information	2
Main Menu Variables	2
Communications	3
Retransmission & Control Outputs	3
Relay Outputs	3
Software Configuration	3
Limitations of Use	4
Approvals	4

## 2 Specifications

Specification Table	7
---------------------	---

## 3 Installation

Panel Mounting	9
Electrical Connection	10
Rear Panel Connections	10
Terminal Designations	10
Inputs	11
Analog Input Connections	11
Logic Input Connection	11
Outputs	12
4-20mA Output Connection	12
Logic Output Connection	12
Control Relays (Alarms)	13
RC Network for Interference Suppression	14
Communications	14
RS-232 Port	14
RS-485 Port	15
Earthing and Shielding	15

## 4 Operation

Normal Operation Mode	17
Default Variable	17
Status LEDs	17
Front Panel Keys	17
Main Menu Items	18
Data Logs	19
Model Information	21
Alarms Menu	21
Operation of Alarms	22

---

<b>5 Instrument Calibration</b>	
Introduction	25
Calibration View Mode	25
Calibration Set Mode	26
Changing the Instrument Settings	27
Calibration Menu Tree	28
Instrument Settings	30
Units of Measurement	30
Parameters	30
Inputs	31
Outputs	36
Alarms	36
Communications	38
Time Settings and Data Logging	40
General Setup Parameters	42
Test Menu	43
System Messages	44
Error Messages	45
Warning Messages	45
Alarm Messages	46
<b>6 Communications</b>	
Overview	47
Hardware Interconnection	47
Protocols	49
Modbus RTU Protocol	49
List of Data Registers	51
Printer Protocol	55
Types of Printouts	56
Printer Data Control	58
<b>Appendix A Model Numbers</b>	
Product Codes	61
Custom Version Codes	62
Application Information Code	62
<b>Appendix B Units of Measurement</b>	
Available Units of Measurement	64
<b>Index</b>	65

# List of Figures

---

1	Typical Application Diagram . . . . .	4
2	Rear Panel Connections . . . . .	10
3	Externally Powered Current Loop . . . . .	11
4	Internally Powered Current Loop . . . . .	11
5	Logic Input Connection Diagram . . . . .	12
6	Output 4-20mA Connection Diagram . . . . .	12
7	Output Logic Connection Diagram . . . . .	13
8	Relay Connection Diagram . . . . .	13
9	RS-485 Interface Connections . . . . .	15
10	Logged Data Display Methods . . . . .	20
11	Calibration Menu Tree Sheet 1 . . . . .	28
12	Calibration Menu Tree Sheet 2 . . . . .	29
13	RS-232 Cable Connections to a Computer . . . . .	48
14	RS-485 Connections . . . . .	48





# Chapter 1

## Introduction

---

### Features

- 20 point level to volume strapping table
- Level control output
- Accepts level and pressure (product head) sensors
- Density correction available for pressure level sensors
- Provides volume to mass conversion via density value
- Freely assignable alarms for high or low levels
- Selection of second language and user tags
- RTC logging with up to 100 entries at user-specified scheduled times
- 4-20mA retransmission
- RS-232 and RS-485 (optional) serial ports
- Modbus RTU, Printer and other serial port protocols
- Front panel adjustment of 8-24V DC output voltage
- Backlit display

### Overview

The 505 LM01 application monitors and measures the level of product in a single tank. The instrument uses the 4-20mA signal from a wide range of level sensors, including pressure transmitters, ultrasonic sensors and capacitance probes.

The level monitor provides a 20 point strapping table and product density for level to volume and volume to mass conversions. The instrument can display Volume, Percentage Full and Mass as well as Level. Relay alarms are freely assignable as high or low alarms and an open collector output is provided for programmable level control.

A sub-menu gives full details of alarm status and can offer direct access to change the alarm setpoints. The instrument also has density correction available for pressure level sensors to cater for a deviation in product density.

## Calculations

The following equations identify the derivation of some of the displayed variables. If your interest is more in the operation of the instrument, you can skip this section and allow the instrument to take care of the calculations.

Calculations are based on the analog input signal representing the product level in the tank.

$$level = (Lmax - Lmin) \times A + Lmin$$

$$volume = (Vmax - Vmin) \times A^* + Vmin$$

$$mass = volume \times density$$

where:

$A$  = normalised input signal with density correction.

$A^*$  =  $A$  for linear tanks.

$A^*$  =  $f(A)$  for non-linear tanks.

$f(A)$  = level to volume normalised strapping table.

## Displayed Information

The front panel display shows the current values of the input variables and the results of the calculations.

The instrument can be supplied with a real-time clock for data logging of up to 100 entries of the variables as displayed on the main menu.

## Main Menu Variables

Main Menu Variables	Default Units	Variable Type
Product Volume	m <sup>3</sup>	Rate
Product Level	m	Rate
Volume Full %	%	Rate
Product Mass	kg	Rate

Refer to [Available Units of Measurement](#) on page 64 for the list of available units.

## Communications

There are two communication ports available as follows:

- RS-232 port
- RS-485 port

The ports can be used for remote data reading, printouts and for initial application loading of the instrument.

## Retransmission & Control Outputs

The instrument can re-transmit any main menu variable. The digital output can be used as logic levels for control outputs. If the instrument has the advanced option, it outputs rates as a 4-20mA signal.

## Relay Outputs

The relay alarms can be assigned to any of the main menu variables of a rate type. The alarms can be fully configured including hysteresis. Two relays are standard.

## Software Configuration

The instrument can be further tailored to suit specific application needs including units of measurement, custom tags, second language or access levels. A distributor can configure these requirements before delivery.

Instrument parameters including units of measurement can be programmed in the field, according to the user access levels assigned to parameters by the distributor.

All set-up parameters and logged data are stored in non-volatile memory with at least 30 years retention.

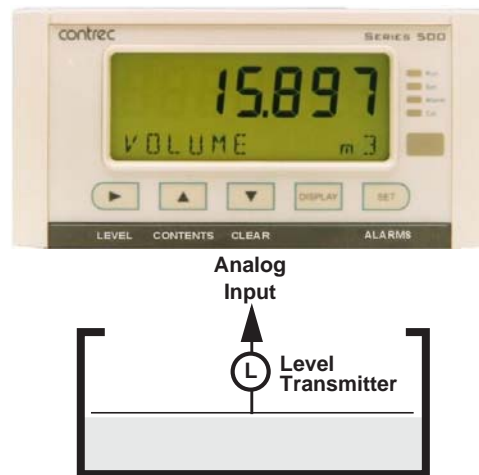

Figure 1 Typical Application Diagram

## Limitations of Use

### Density Correction for Pressure Level Sensors

Density correction has been provided for use with pressure level sensors to cater for a deviation in the product density. This correction is only used in the calculations when the minimum and maximum points for the level input have been programmed in a conventional manner. That is, the level corresponding to the 20mA point is greater than the level for the 4mA point.

## Approvals

This instrument conforms to the EMC-Directive of the Council of European Communities 2014/30/EU, the LVD safety directive 2014/35/EU and the following standards:

- *EN61326:2013* Electrical equipment for measurement, control and laboratory use – EMC requirements: Industrial Environment.
- *EN61010:2010* Safety requirements for electrical equipment for measurement, control, and laboratory use.

In order to comply with these standards, the wiring instructions in **Chapter 3 - Installation** must be followed.

## **FCC Declaration**

This equipment has been tested and found to comply with the limits for a Class A digital device, pursuant to Part 15 of the FCC Rules. These limits are designed to provide reasonable protection against harmful interference when the equipment is operated in a commercial environment. This equipment generates, uses, and can radiate radio frequency energy and, if not installed and used in accordance with the instruction manual, might cause harmful interference to radio communications. Operation of this equipment in a residential area is likely to cause harmful interference, in which case the user will be required to correct the interference at his own expense.

Properly shielded and grounded cables and connectors must be used in order to meet FCC emission limits. Contrec Ltd is not responsible for any radio or television interference caused by using other than recommended cables and connectors or by unauthorized changes or modifications to this equipment. Unauthorized changes or modifications could void the user's authority to operate the equipment.

This device complies with Part 15 of the FCC Rules. Operation is subject to the following two conditions: (1) this device might not cause harmful interference, and (2) this device must accept any interference received, including interference that might cause undesired operation.



# Chapter 2

## Specifications

### Specification Table

<p><b>Operating Environment</b></p> <p><b>Temperature</b> 0°C to +60°C (conformal coating) +5°C to +40°C (no coating)</p> <p><b>Humidity</b> 0 to 95% non condensing (conformal coating) 5% to 85% non condensing (no coating)</p> <p><b>Power Supply</b> 95-135 V AC or 190-260 V AC or 12-28 V DC</p> <p><b>Consumption</b> 6W (typical)</p> <p><b>Protection</b> Sealed to IP65 (Nema 4X) when panel mounted</p> <p><b>Dimensions (panel option)</b> 147mm (5.8") width 74mm (2.9") height 167mm (6.6") depth</p>	<p><b>4-20mA Input</b></p> <p><b>Overcurrent</b> 100mA absolute maximum rating</p> <p><b>Impedance</b> 250 Ohms (to common signal ground)</p> <p><b>Accuracy</b> 0.1% typical full scale (20°C) 0.2% (full temperature range)</p> <p><b>Non-linearity</b> Up to 20 correction points (flow inputs)</p>
<p><b>Display</b></p> <p><b>Type</b> Backlit LCD with 7-digit numeric display and 11-character alphanumeric display</p> <p><b>Digits</b> 15.5mm (0.6") high</p> <p><b>Characters</b> 6mm (0.24") high</p> <p><b>LCD Backup</b> Last data visible for 15min after power down</p> <p><b>Update Rate</b> 0.3 second</p>	<p><b>Remote Key Input</b></p> <p><b>Signal Type</b> CMOS, TTL, open collector, reed switch</p> <p><b>Configuration</b> One input set as one of front five keys</p>
<p><b>Non-volatile Memory</b></p> <p><b>Retention</b> &gt; 30 years</p> <p><b>Data Stored</b> Setup, Totals and Logs</p>	<p><b>Relay Output</b></p> <p><b>No. of Outputs</b> 2 relays</p> <p><b>Voltage</b> 250 volts AC, 30 volts DC maximum</p> <p><b>Current</b> 3A maximum</p>
<p><b>Approvals</b></p> <p><b>Interference</b> CE compliance</p> <p><b>Enclosure</b> IECEx, ATEX and CSA approved enclosures available for hazardous areas</p>	<p><b>Communication Ports</b></p> <p><b>Ports</b> RS-232 port RS-485 port</p> <p><b>Baud Rate</b> 2400 to 19200 baud</p> <p><b>Parity</b> Odd, even or none</p> <p><b>Stop Bits</b> 1 or 2</p> <p><b>Data Bits</b> 8</p> <p><b>Protocols</b> Modbus RTU, Printer*</p>
<p><b>Real Time Clock (Optional)</b></p> <p><b>Battery Type</b> 3 volts Lithium button cell (CR2032)</p> <p><b>Battery Life</b> 5 years (typical)</p>	<p><b>Transducer Supply</b></p> <p><b>Voltage</b> 8 to 24 volts DC, programmable</p> <p><b>Current</b> 70mA @ 24V, 120mA @ 12V maximum</p> <p><b>Protection</b> Power limited output</p>
	<p><b>Pulse/Digital Output</b></p> <p><b>Signal Type</b> Open collector, non-isolated</p> <p><b>Switching</b> 200mA, 30 volts DC maximum</p> <p><b>Saturation</b> 0.8 volts maximum</p>

**4-20mA Output (Optional)**

<b>Supply</b>	24 volts DC internal, non-isolated
<b>Resolution</b>	0.05% full scale
<b>Accuracy</b>	0.05% full scale (20°C) 0.1% (full temperature range, typical)

*Important: Specifications are subject to change without notice.  
Printer protocol is available only if RTC option is installed.*



# Chapter 3

## Installation

---

### Panel Mounting

The instrument should be located in an area with a clean, dry atmosphere that is also relatively free of shock and vibration.

The standard mounting procedure is panel mounting in a cutout that is 139mm wide by 67mm high. Two side clips secure the unit into the panel.

Figure 2 shows the panel mounting requirements for the 500 Series Instrument.

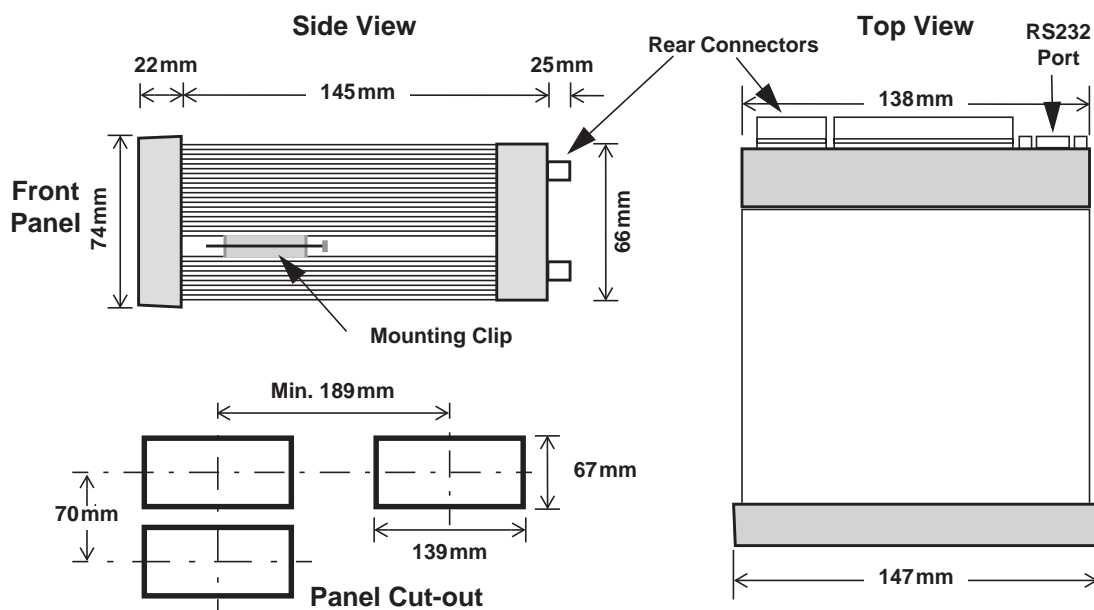

500 Series Instrument Panel Mounting

# Electrical Connection

## Rear Panel Connections

Figure 2 shows the connections on the rear panel of the instrument.

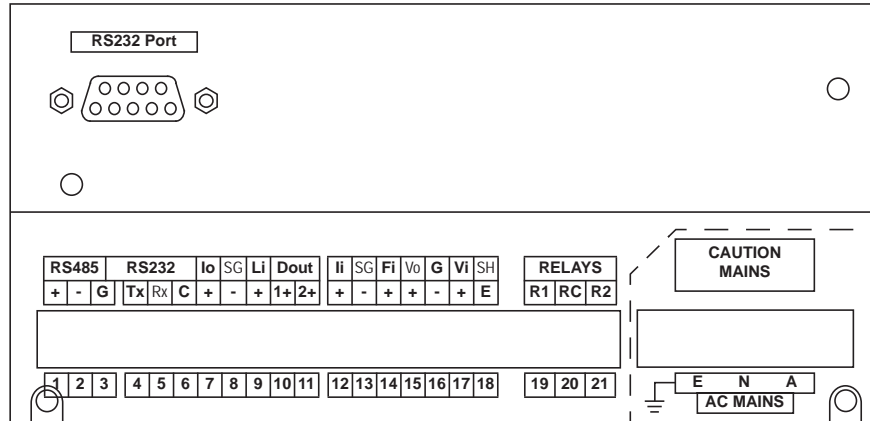

Figure 2 Rear Panel Connections

## Terminal Designations

Terminal Label	Designation	Comment
1	RS485	+ RS485 (+)
2		- RS485 (-)
3	G	Comms ground
4	RS232	Tx RS232 data out
5		Rx RS232 data in
6		C CTS (Clear to send)
7	Io	+ 4-20mA output
8	SG	- Signal Ground 0V
9	Li	+ Logic input
10	D OUT	1+ Open collector o/p 1
11		2+ Open collector o/p 2
12	li	+ 4-20mA input
13	SG	- Signal Ground 0V
14	Fi	+ Frequency input
15	Vo	+ 8-24 volts DC output
16	G	- DC Ground
17	Vi	+ DC power input
18	SH	E Shield terminal
19	RELAYS	R1 Relay 1
20		RC Relay Common
21		R2 Relay 2
E	AC MAINS	E Mains ground
N		N Mains neutral
A		A Mains active
RS232 port		9-pin serial port

# Inputs

## Analog Input Connections

The analog input (Ii) can accept current signals from 4 to 20mA.

### CAUTION

Applying levels of input current above the absolute maximum rating (100mA) may cause permanent damage to the input circuitry.

### 4-20mA Inputs

For an externally powered current loop, connect the transmitter to the input terminals as shown in Figure 3.

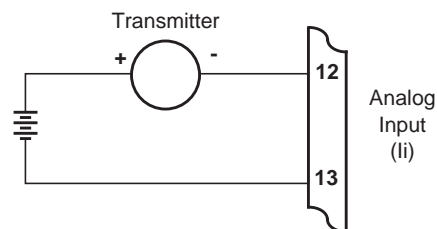

Figure 3 Externally Powered Current Loop

Connect internally powered current loop as shown in Figure 4.

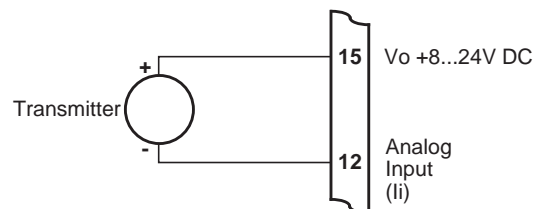

Figure 4 Internally Powered Current Loop

## Logic Input Connection

These input(s) are designed to be connected to open collector signals or a voltage free contact switch. A minimum activation time of 300ms is required to guarantee reading of an input.

### Remote Key Input

A remote push-button key can be connected to the Logic Input as shown below. Refer to **REMOTE KEY** on page 35 to define the function of the key.

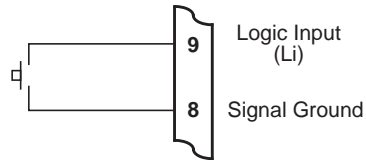

Figure 5 Logic Input Connection Diagram

## Outputs

The basic instrument has two digital logic outputs (in this application only DOUT1 is used). The advanced option also provides a 4-20mA output port.

### 4-20mA Output Connection

Figure 6 shows the connections for a 4-20mA output.

Maximum Load Resistance = 900 ohms

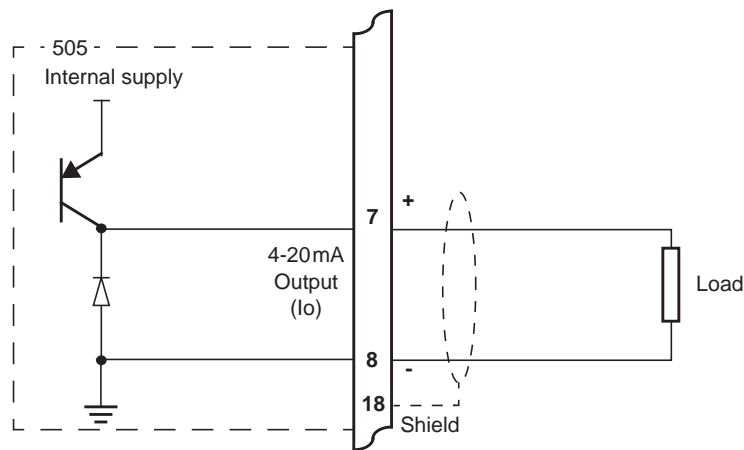

Figure 6 Output 4-20mA Connection Diagram

### Logic Output Connection

Figure 7 shows a connection example for a logic control output. Output channel 1 uses terminals 10 (+) and 8 (-). Output channel 2 uses terminals 11 (+) and 8 (-).

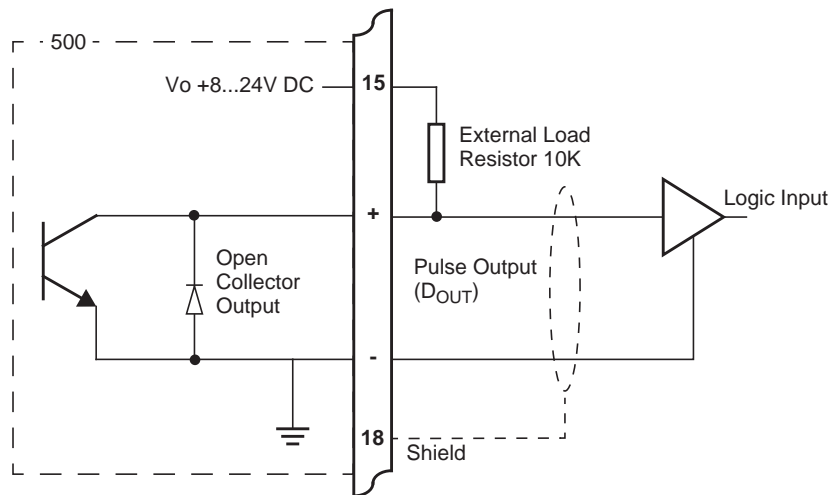

Figure 7 Output Logic Connection Diagram

## Control Relays (Alarms)

The standard instrument has two alarm relays, which can be used to drive external devices such as external relays, LEDs, and audible alarms. The operation of alarm relay(s) can be set to various modes as described in [Alarms](#) on page 36.

There is also an equipment failure alarm option. This alarm can have normally closed (open) contacts which open (close) when the instrument displays any error message as listed in [Error Messages](#) on page 45, or if there is a loss of power to the instrument.

The output characteristics of the relays are:

Maximum Voltage 30 volts DC or 250 volts AC  
 Maximum Current 3 A

**Note:** Solid state relays use AC voltage only.

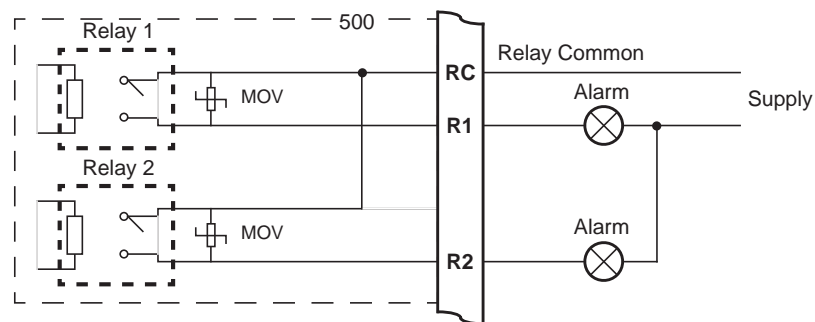

Figure 8 Relay Connection Diagram

## RC Network for Interference Suppression

When driving highly inductive loads with the relay outputs, it is recommended to use RC suppression networks (often called “Snubbers”) for the following reasons:

- To limit the amount of electrical noise caused by arcing across the contacts, which may, in extreme cases, cause the microprocessor to act erratically.
- To protect the relay contacts against premature wear through pitting.

RC suppression networks consist of a capacitor and series resistor and are commonly available in the electrical industry. The values of R and C are dependent entirely on the load. However, if the user is unsure of the type of snubber to use, values of 0.25  $\mu$ F and 100 $\Omega$  will usually suffice. Note that only mains-approved RC suppression networks should be used.

The basic principle of the operation is that the capacitor prevents a series of sparks arcing across the contact as the contact breaks. The series resistor limits the current through the contact when the contact first makes.

## Communications

The communication protocols are described in [Communications](#) on page 47.

### RS-232 Port

The standard RS-232 port uses terminals 4, 5 and 6 on the rear panel.

The extra RS-232 port 9-pin DB female connector has the following pinout:

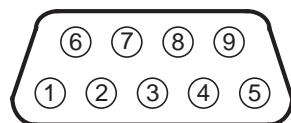

Pin 1	Not used
Pin 2	Transmit (TxD)
Pin 3	Receive (RxD)
Pin 4	Not used
Pin 5	Ground
Pin 6	Not used
Pin 7	Handshake line (CTS)
Pin 8	RTS Out
Pin 9	Not used

**Note:** The instrument does not require a null-modem cable for connection to a personal computer. Refer to **Hardware Interconnection** on page 47 for cable termination requirements.

## RS-485 Port

Up to 32 units can be connected to a common RS-485 bus. Each unit has a unique address that the host computer uses to identify each instrument.

Figure 9 shows the connection of several instruments to a computer using the RS-485 port.

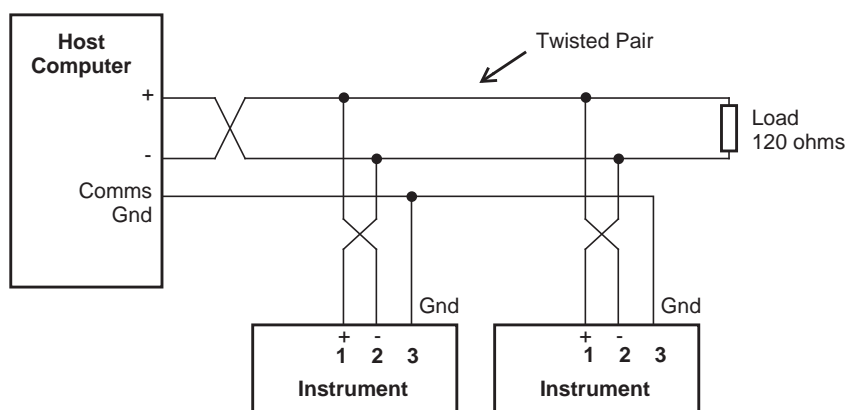

*Figure 9 RS-485 Interface Connections*

## Earthing and Shielding

It is a good practice to use shielded cable for all signal connections to the instrument. Care must be taken to separate signal cables from power cables to minimize interference.

Overall earth should be connected at the instrument end only. This connection should be as short as possible and connected to the earthing point on the rear terminal at pin 18.





# Chapter 4

## Operation

---

### Normal Operation Mode

In normal operation mode, you press the buttons on the front panel to display the values recorded and calculated by the instrument. There are four categories of information that the instrument can display:

- Level variables
- Contents variables
- Alarm setpoints
- Instrument settings

### Default Variable

In some applications, a particular variable is of more interest than others, and for this reason a default variable can be assigned during instrument calibration. The default is used in the following way:

- The default variable determines what the display returns to if the display timeout option is enabled and no buttons are pressed for the selected period (usually 30 seconds). It also determines what is displayed on power up.

### Status LEDs

The status LEDs illuminate to show the following conditions:



- Run** An instrument operation is in progress.  
**Set** The instrument is in Calibrate Set mode.  
**Alarm** The instrument has an error, as indicated on the display panel.  
**Cal** The instrument is in Calibrate View mode.

### Front Panel Keys

For most actions with the front panel keys, you can hold a key to scroll through the values or options, instead of repeatedly pressing the key.

- LEVEL** Press the **LEVEL** key to display the current tank level. If there is more than one level variable, press or hold the **LEVEL** key to display the other level variables in turn.

**CONTENTS** Press the **CONTENTS** key to display the current tank contents. When a contents variable is displayed, press or hold the **CONTENTS** key to display the other contents variables in turn.

**CLEAR** Use the **CLEAR** key to clear and acknowledge relay alarms or to initiate a printout if the printer option has been selected. The printout is activated with a single press and gives two beeps while the Clear Alarms Key parameter in calibration can be enabled or disabled during instrument calibration and functions as follows:

- DISABLE - The user cannot clear or acknowledge any relay alarms.
- ENABLE - Holding the **CLEAR** key for two seconds will acknowledge and clear all active relays, while individual alarm relays can be cleared in the Alarms Menu with a single press of the clear key.

**DISPLAY** Press the **DISPLAY** key to step or scroll through the main menu items.

**ALARMS** Press the **ALARMS** key, while viewing any main menu variable, to enter the alarms menu. For full details see **Alarms Menu** on page 21.

## Main Menu Items

The main menu in this instrument consists of the following items. The **DISPLAY** key is used to step or scroll through the list.

<b>DISPLAY</b> ↓	<b>Description</b>	<b>Options</b>
VOLUME	Product volume	Press the <b>ALARMS</b> key to enter the Alarms menu
LEVEL	Product level	Press the <b>ALARMS</b> key to enter the Alarms menu
% FULL	Volume full percentage	Press the <b>ALARMS</b> key to enter the Alarms menu
MASS	Product mass	Press the <b>ALARMS</b> key to enter the Alarms menu
REPORT PRINT	Only shown if print option is selected	Hold the <b>SET</b> key to print log report as defined in the TM/LOG section of calibration.
LOGGED DATA	Only shown if real-time clock option is installed	Hold the <b>SET</b> key to display data logs as described in <b>Data Logs</b> on page 19.
MODEL INFO		Hold the <b>SET</b> key to display the Model information as described in <b>Model Information</b> on page 21.
CAL MENU		Hold the <b>SET</b> key to enter Calibration View mode as described in <b>Calibration View Mode</b> on page 25.

## Data Logs

The instrument will log the main-menu variables if real-time clock option is installed. The logs are at fixed intervals which can be programmed to a combination of hours, days, weeks, months and years. The instrument can store a total of 100 log entries.

If the number of log entries exceeds the programmed number for a particular time interval, the oldest log entry is overwritten by the newest one for that time interval.

The log entries are recorded at the following times:

HOUR	00 minutes each hour
DAY	00 hours and 00 minutes each day
WEEK	00 hours and 00 minutes each Monday
MONTH	00 hours and 00 minutes on the first day of the month
YEAR	00 hours and 00 minutes on the first day of the year.

### View Data Logs

Use the following procedure to view the data that has been logged by the instrument:

1. Press the **DISPLAY** key to scroll through the menu to the **LOGGED DATA** prompt.
2. Hold the **SET** key.

The system displays the hourly log. The timebase and number of the log are shown, for example LH-001.

3. While holding the **DISPLAY** key use the **CLEAR** key to print the data for the displayed log if the printer option has been selected.

The following example shows the hourly log number 006 at 15:00 (3:00 pm) on 16 January 2016. The day and month alternate with the year in the bottom right hand corner.



Figure 10 shows how to display the logged data.

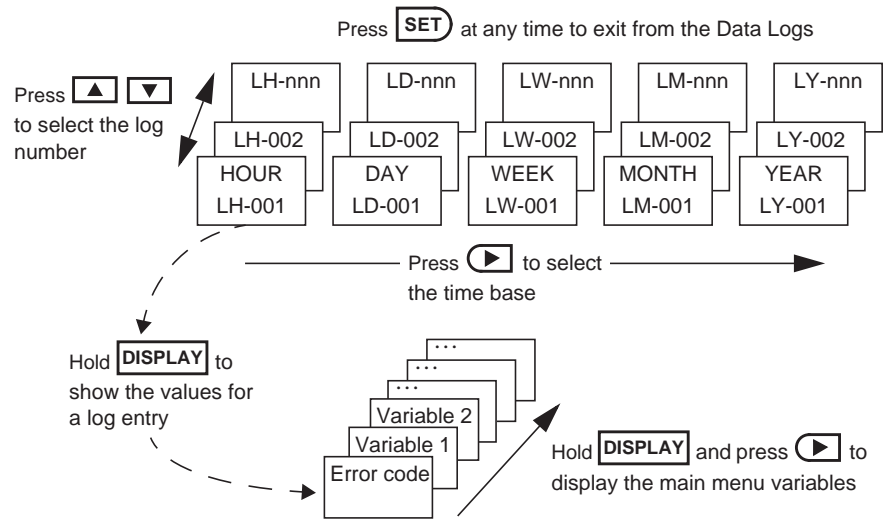

Figure 10 Logged Data Display Methods

## Model Information

The model information items display the hardware, software and application versions of the instrument. This information is mainly for service personnel.

DISPLAY ↓	Description
1- 1- - 5- 505 MODEL	The hardware model code. Refer to <b>Product Codes</b> on page 61 for more information.
- L LM01 INPUT	The Application number and the assignment of the inputs. Refer to <b>Application Information Code</b> on page 62 for more information.
0 10 1.002 LM01 VERS	The version of software loaded into the instrument.
026357 CUSTOM VERS	The Customer version code for this installation. Refer to <b>Custom Version Codes</b> on page 62 for more information.
123456 ABC123 S/N	The instrument serial number and unit tag. The serial number is on the top line and unit tag is on the bottom left. Both items are entered when the instrument application software is initially loaded. If the unit tag is not used the default tag, UNIT, will be used.
16- 15 EDITED 27/08 2016	The time and date when the calibration of the instrument was last edited. The format of the time and date is the same as for the data logs. This example shows 16:15 (4:15pm) on the 27th August 2016.  This function is available only if the instrument has the real time clock option.

Press **SET** at any time to exit from the Model information.

## Alarms Menu

The alarms menu allows information about individual alarms to be viewed. If multiple alarms are active at one time it can allow the alarms to be individually acknowledged.

On entering the alarms menu with the **ALARMS** key the **Cal** indicator will illuminate and the first item, ALARM 1, will be displayed.

**DISPLAY** Press the **DISPLAY** key to step or scroll around through the other alarms in the order of the alarm number. The instrument will exit the alarms menu whenever the **LEVEL** or **CONTENTS** keys are pressed or a timeout of 30 seconds, with no key presses, expires.

An alarm menu item consists of the alarm number, type, assignment and setpoint as shown in the following example:

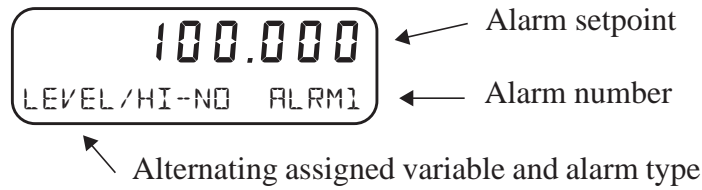

The **Alarm** led indicates the status of the alarm being viewed.

- Led flashing = Alarm ACTIVE
- Led solid = Alarm ACKNOWLEDGED
- Led off = Alarm IDLE.

If the alarm being viewed has been assigned as an Equipment Alarm (AL-NC) it will be displayed in the following form. An Equipment Alarm relay can not be cleared and pressing the **CLEAR** key will have no effect.

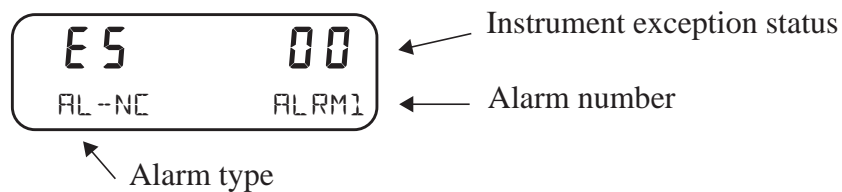

The exception status code is the same as that used for communications. For a full list see [Instrument Exception Status](#) on page 53.

### Changing Alarm Setpoints

- SET** An alarm setpoint can only be edited if the Direct Edit Access parameter was enabled during instrument calibration. Hold the **SET** key, the display of the setpoint will change from view mode to edit mode after two seconds. Once in edit mode the **Set** indicator will illuminate and the setpoint values are changed in exactly the same way as in calibration set mode. Press the **SET** key again to exit edit mode and return to the alarm item.

## Operation of Alarms

The alarms can be freely assigned to any of the main menu variables as high or low alarms and can also be assigned to be an equipment alarm.

When a high or low alarm condition is detected the relay will activate, the **Alarm** led will flash and the message for that alarm will be scrolled across the display. The alarm will remain active until the alarm condition is no longer true at which point it is automatically cleared and the relay will deactivate, the led will turn off and the message will stop being displayed.

---

When Clear Alarms Key is enabled the alarm can be acknowledged and the relay cleared from the main menu by pressing the **CLEAR** key for two seconds. This will acknowledge all active alarms, the instrument will sound three beeps, the relays will be deactivated, the **Alarm** led will go from a flashing to solid state and the relevant alarm message will continue to scroll. When the alarm condition is no longer present the led will turn off, the message will stop being displayed and the alarm will be re-armed to activate when the condition is detected again.

If there are multiple alarms present at the same time only the highest priority alarm message will be displayed in the main menu (relays operate regardless of priority). The alarms menu can be used to view the status of all alarms and acknowledge them individually with a short press of the **CLEAR** key (or, like above, acknowledge all active alarms by holding the **CLEAR** key for two seconds). Any acknowledged alarm takes a lower priority than a non-acknowledged alarm. Hence the priority list of alarms on this instrument is as follows:

Alarm 1 Active	Highest priority
Alarm 2 Active	<b>Alarm</b> led flashing, Relay activated
Alarm 1 Acknowledged	<b>Alarm</b> led solid, Relay deactivated
Alarm 2 Acknowledged	Lowest priority

The key indication that the alarm being scrolled on the display is acknowledged or not is the status of the **Alarm** led.





# Chapter 5

## Instrument Calibration

---

### Introduction

You can view or change the settings of the instrument according to the access level for each parameter as set by the manufacturer. There are four levels of access to the parameters as follows:

- **Not visible** - you cannot display or edit the parameter.
- **Display Only** - you can display the parameter, but you cannot change the setting.
- **Programmable** - you can change the setting of the parameter in Calibration Set mode.
- **Password protected** - you can change the setting of the parameter in Calibration Set mode only if you enter the correct password.

**Note:** When you enter Calibration Set mode, the instrument requests you to enter a password. Any value will allow to change the settings of the “programmable” parameters, but the correct password must be entered to change the password-protected parameters.

### Calibration View Mode

Use the following procedure to view the calibration settings of the instrument:

1. Press **DISPLAY** to scroll to the **CFM MENU** prompt.
2. Hold the **SET** key.



The instrument beeps once, illuminates the **Cal** indicator and shows **CFM** on the display panel.

- Press **▶** to scroll through the flashing menu headings.
  - Press **SET** to scroll through submenu items.
  - Press **DISPLAY** to return to the main calibration menu.
3. To exit from the Calibration View mode, press **▶** to scroll to the **END** option and press **SET**.

The instrument returns to Normal Operation mode.

## Calibration Set Mode

In Calibration Set mode, you can change the settings of the “programmable” parameters. You must enter the system password to change the setting of the “password-protected” parameters.

Use the following procedure to enter Calibration Set mode:

1. Press **DISPLAY** to scroll to the **FL MENU** prompt.
2. Hold the **SET** key.



The instrument beeps once, illuminates the **Cal** indicator and shows **FL** on the display panel.

3. Press **▶** to select any flashing menu heading except **END**.
4. Hold **SET** for two seconds.  
The instrument requests a password.
5. Press **▲** or **▼** to change the value of the current digit. To select the next digit, press **▶**.
6. Press **SET** to accept the password.
  - The instrument makes two beeps for a correct password entry and enables you to change the “programmable” and “password-protected” parameters.
  - The instrument makes one beep for an incorrect password entry and enables you to change only the “programmable” parameters.



The instrument illuminates both the **Cal** and **Set** indicators.

7. Edit the instrument parameters as required. The programmable values are indicated by the flashing display.
  - To change a numerical value, press **▲** to increase a value, or press **▼** to decrease a value. Press a key momentarily to change the value one number at a time. Hold a key to scroll through the numbers. To proceed to next digit, press **▶**.
  - To change an option setting, press **▲** or **▼** to scroll through the options.
8. Press **SET** to accept the currently displayed value and proceed to the next parameter. You can press **DISPLAY** to return to the main calibration menu.
9. To exit from Calibrate Set mode, press **▶** to scroll through the main calibration menu to **END**, then press **SET**. Otherwise, from any menu, you can press and hold **SET** for two seconds.



The instrument makes two beeps and cancels the **Cal** and **Set** indicators.

## Changing the Instrument Settings

In Calibration Set mode, the display flashes the item that can be changed. For option settings, the display flashes the complete option. For a numeric parameter, the display flashes one digit at a time, you can change the value of the flashing digit as required, then move the flashing cursor to change another digit.

**Note:** When you change the setting of a parameter, the instrument records the result as soon as you move to another parameter, or exit from the Calibration Set mode.

### Changing Option Settings

When you display an option that can be changed, the entire option flashes on the display, such as the choices of ODD, EVEN or NONE for the communications parity bit checking. Press  or  to change the option. You can “scroll” through the options in either direction to make a selection as shown below.

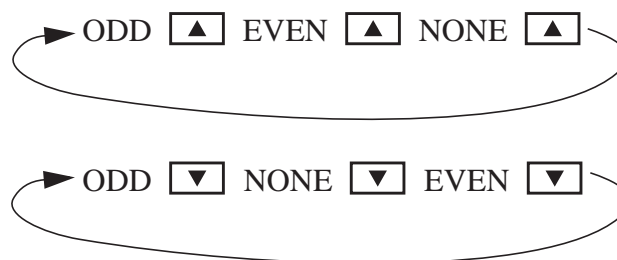

### Changing Numeric Settings

The display flashes the digit that can be changed.



Press  to select the digit that you wish to change.

Press  or  to increase or decrease the value of the selected digit.

### Changing the Decimal Point

To change the position of the decimal point, press  to move the flashing selection until the decimal point flashes. Press  or  to move the decimal point to the right or left as required.

### Units of Measurement

The calibration of some parameters is based on the units that are defined for the relevant variables. These units of measurement can be viewed in the UNITS menu in calibration below.

# Calibration Menu Tree

Figure 11 and Figure 12 show the keys for moving around the calibration menu tree in Calibration View or Set mode.

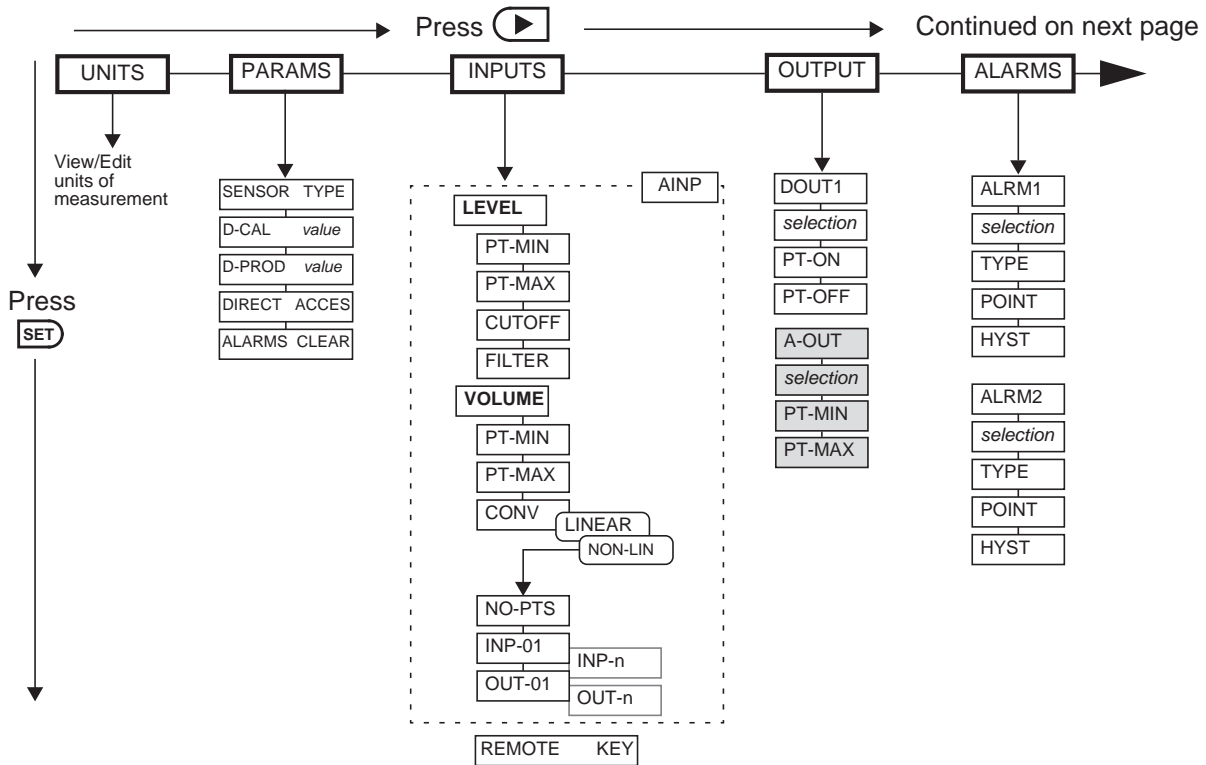
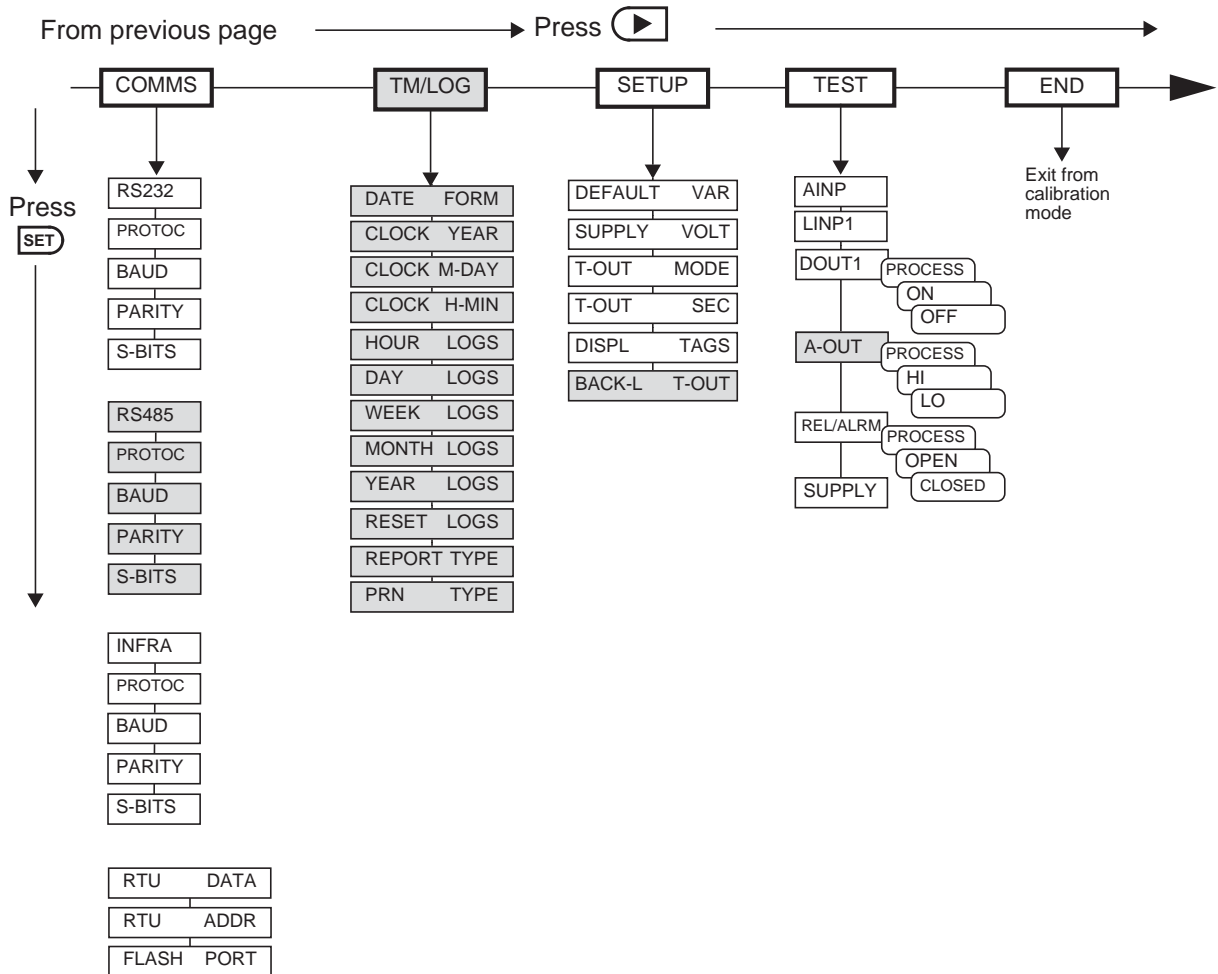

Figure 11 Calibration Menu Tree Sheet 1



The shaded boxes indicate advanced options

Press [DISPLAY] at any point to return to the main calibration menu.

Press [▶] at any I/O assignment position to move to the next I/O assignment in the submenu (eg pressing [▶] on ALRM1 will move you to ALRM2)

Figure 12 Calibration Menu Tree Sheet 2

# Instrument Settings

## Units of Measurement

The Units menu allows the units to be viewed and edited if necessary without the reloading of new application software. Any change in units will result in a full reset to initially downloaded settings. Therefore, any required changes to units of measurement should be made before changing any other settings.

[SET] ↓	▶ → <b>UNITS</b> PARAMS INPUTS OUTPUTS ALARMS COMMS TM/LOG SETUP TEST END
ITEM <i>n</i> <i>unit</i>	<p>The units for main menu or calibration items can be viewed by pressing the [SET] key.</p> <p>The units of measurement are password protected. To edit the units the correct password must be entered on entry to EDIT mode.</p> <p>Press ▲ or ▼ to select the required units. Refer to <b>Available Units of Measurement</b> on page 64 for the list of available units.</p>
ACCEPT    UNITS	<p>The Accept Units prompt will only appear if one or more of the units have been changed.</p> <p><b>IMPORTANT:</b> Accepting the change of units will initiate a master reset. All calibration parameters will revert to their default value (i.e. those values included in the downloaded instrument software). All totals and any logged information will be cleared.</p> <p>Press ▲ or ▼ to select YES, then press the [SET] key. The instrument makes three beeps to confirm the reset command.</p> <p>The message -RESET- PLEASE WAIT will be displayed as the instrument exits calibration mode and completes a full re-boot sequence.</p>

## Parameters

[SET] ↓	▶ → UNITS <b>PARAMS</b> INPUTS OUTPUTS ALARMS COMMS TM/LOG SETUP TEST END
SENSOR    TYPE	<p>Select the type of sensor being used. A pressure sensor (measuring product head) or a level sensor can be selected.</p> <p>Press ▲ or ▼ to select LEVEL or PRESSUR.</p>
D-CAL <i>unit</i>	<p>The calibration density is the density of the product at the time of the tank calibration. This parameter is required only when a pressure sensor is selected.</p>

<b>SET</b> ↓	<b>▶</b> → UNITS <b>PARAMS</b> INPUTS OUTPUTS ALARMS COMMS TM/LOG SETUP TEST END
D--PROD <i>unit</i>	The product density is used to provide the product mass based on the calculated volume of product.
DIRECT ACCES	<p>If the alarm setpoint direct access is enabled then the operator is able to enter edit mode for the setpoint directly from the alarm menu by holding the <b>SET</b> key while viewing the setpoint. If disabled the setpoint can only be changed from within calibration set mode. Select the direct access mode as required.</p> <p>Press <b>▲</b> or <b>▼</b> to select ENABLE or DISABLE.</p>
ALARMS CLEAR	<p>If the “clear alarms key” is enabled then the operator is able to acknowledge and deactivate the relay of an active alarm by pressing the <b>CLEAR</b> key.</p> <p>Holding the clear key for two seconds will acknowledge and clear all active relays, while individual alarm relays can be cleared in the Alarms Menu with a single press of the clear key.</p> <p>Press <b>▲</b> or <b>▼</b> to select ENABLE or DISABLE.</p>

## Inputs

<b>SET</b> ↓	<b>▶</b> → UNITS PARAMS <b>INPUTS</b> OUTPUTS ALARMS COMMS TM/LOG SETUP TEST END
<b>Analog Input</b>	
INPUT LEVEL AINP	For this application, the 4-20mA Analog Input is assigned to level.
PT-MIN LEVEL PT-MAX	<p>Enter the value of the level (in the defined engineering units) that corresponds to the minimum input signal.</p> <p>Enter the value of the level (in the defined engineering units) that corresponds to the maximum input signal.</p> <p>For example, if the source signal is 4mA at a minimum level of 2m, enter 2 as the minimum point. If the source signal is 20mA at a maximum level of 5m, enter 5 as the maximum point.</p> <p>If the sensor is inverted the value entered for the minimum point will be greater than the value entered for the maximum point</p>

SET ↓	▶ → UNITS PARAMS <b>INPUTS</b> OUTPUTS ALARMS COMMS TM/LOG SETUP TEST END		
CUTOFF RINP	<p>The Cut-off is the lowest value that the instrument reads from the input sensor. The cut-off setting is the percentage of the span of the input values.</p> <p>All inputs at or below the cut-off value are considered negligible to the instrument and are ignored. In this case, the instrument uses the minimum value (set at PT-MIN).</p>		
FILTER RINP	<p>Input fluctuations caused by pulsating signal tend to create distortion in the input readings of the level. The instrument has a digital filter that averages out these fluctuations.</p> <p>As a guide to the degree of filtering to use, the following table shows the response time (in seconds) to reach 90% and 99% of a step change in input.</p> <p>The value A is the filter constant that the user can set.</p>		
	<b>Filter setting A</b>	Seconds to reach 90% of full swing	Seconds to reach 99% of full swing
	0	0	0
	2	2	4
	4	4	8
	6	5	10
	10	8	15
	15	12	23
	20	14	27
	25	18	34
	35	25	48
	45	32	62
	60	42	82
	75	52	102
	90	62	122
	99	68	134
	The input filter range is from 0 to 99. A setting of 0 (zero) means that there is no filtering.		



SET ↓	▶ → UNITS PARAMS <b>INPUTS</b> OUTPUTS ALARMS COMMS TM/LOG SETUP TEST END
PT--MIN PT--MAX	VOL <p>Enter the value of the tank volume (in the defined engineering units) that corresponds to the level minimum input signal (volume at 4mA).</p> <p>Enter the value of the tank volume (in the defined engineering units) that corresponds to the level maximum input signal (volume at 20mA). The maximum point is the same as the base value (set at the minimum point) plus the span value.</p> <p>For example, if the source signal is 4mA at a minimum volume of 10m<sup>3</sup>, enter 10 as the minimum point. If the source signal is 20mA at a maximum volume of 100m<sup>3</sup>, enter 100 as the maximum point.</p>
CONV	VOL <p>The instrument can be programmed to correct for the non-linearities in irregular shaped tanks. These tanks have a non-linear relationship between the level and volume of liquid which can be corrected with a normalised strapping table.</p> <p>Tank volume conversion type can be selected as follows:</p> <ul style="list-style-type: none"> <li>• LINEAR level to volume relationship, strapping table not required.</li> <li>• NON-LINEAR level to volume relationship, normalised strapping table used for level to volume conversion.</li> </ul> <p>Use ▲ or ▼ to select LINEAR or NON-LINEAR.</p>
NO--PTS	VOL <p><i>This parameter is available for viewing and editing only when the conversion type is set to Non-linear.</i></p> <p>Enter the number of conversion points required for the normalised level to volume tank strapping table.</p> <p>Press ▲ or ▼ to select a number between 1 and 20 for the number of conversion points.</p>

<div style="border: 1px solid black; padding: 2px;">SET</div> ↓	<div style="border: 1px solid black; padding: 2px;">▶</div> → UNITS PARAMS <b>INPUTS</b> OUTPUTS ALARMS COMMS TM/LOG SETUP TEST END
INP-01 TABLE to INP-n	<p><i>This parameter is available for viewing and editing only when the conversion type is set to Non-linear.</i></p> <p>Enter the normalised input value for the conversion point.</p> <p>Data on tank non-linearity is usually supplied by the tank manufacturer, in the form of strapping tables. If this data is not available, the user will need to determine the relationship between level and volume. This can be done mathematically by equations, or experimentally, by conducting physical measurements. In either case, the data must be entered as normalised values.</p> <p>The instrument uses linear interpolation between the correction points. An input and an output value are entered for each correction point. The values are normalised between the minimum point (0.0) and the maximum point (1.0). Only the points between 0 and 1 are required to be entered and should be entered in ascending order.</p> <p>You can press the <div style="border: 1px solid black; padding: 2px;">DISPLAY</div> key to skip the non-linear points and go to the next item.</p>

SET ↓	▶ → UNITS PARAMS <b>INPUTS</b> OUTPUTS ALARMS COMMS TM/LOG SETUP TEST END																																																																																										
	<p><b>Example.</b> A spherical tank has a diameter of 10m. The level at the minimum input signal (PT-MIN) is 0.5m and the level at the maximum input signal (PT-MAX) is 10.0m. The corresponding minimum and maximum volume points have been calculated as PT-MIN = 3.796m<sup>3</sup> and PT-MAX = 523.599m<sup>3</sup>. The following 15 point relationship has been determined:</p> <table border="1"> <thead> <tr> <th>Correction Points Example</th> <th>Level (m)</th> <th>Input</th> <th>Volume (m<sup>3</sup>)</th> <th>Output</th> </tr> </thead> <tbody> <tr><td>min</td><td>0.500</td><td>0.000</td><td>3.796</td><td>0.000</td></tr> <tr><td>1</td><td>1.094</td><td>0.063</td><td>17.421</td><td>0.026</td></tr> <tr><td>2</td><td>1.688</td><td>0.125</td><td>39.699</td><td>0.069</td></tr> <tr><td>3</td><td>2.281</td><td>0.188</td><td>69.314</td><td>0.126</td></tr> <tr><td>4</td><td>2.875</td><td>0.250</td><td>104.951</td><td>0.195</td></tr> <tr><td>5</td><td>3.469</td><td>0.313</td><td>145.295</td><td>0.272</td></tr> <tr><td>6</td><td>4.063</td><td>0.375</td><td>189.031</td><td>0.356</td></tr> <tr><td>7</td><td>4.656</td><td>0.438</td><td>234.844</td><td>0.444</td></tr> <tr><td>8</td><td>5.250</td><td>0.500</td><td>281.418</td><td>0.534</td></tr> <tr><td>9</td><td>5.844</td><td>0.563</td><td>327.438</td><td>0.623</td></tr> <tr><td>10</td><td>6.438</td><td>0.625</td><td>371.590</td><td>0.708</td></tr> <tr><td>11</td><td>7.031</td><td>0.688</td><td>412.557</td><td>0.786</td></tr> <tr><td>12</td><td>7.625</td><td>0.750</td><td>449.025</td><td>0.857</td></tr> <tr><td>13</td><td>8.219</td><td>0.813</td><td>479.678</td><td>0.916</td></tr> <tr><td>14</td><td>8.813</td><td>0.875</td><td>503.202</td><td>0.961</td></tr> <tr><td>15</td><td>9.406</td><td>0.938</td><td>518.280</td><td>0.990</td></tr> <tr><td>max</td><td>10.000</td><td>1.000</td><td>523.599</td><td>1.000</td></tr> </tbody> </table>	Correction Points Example	Level (m)	Input	Volume (m <sup>3</sup> )	Output	min	0.500	0.000	3.796	0.000	1	1.094	0.063	17.421	0.026	2	1.688	0.125	39.699	0.069	3	2.281	0.188	69.314	0.126	4	2.875	0.250	104.951	0.195	5	3.469	0.313	145.295	0.272	6	4.063	0.375	189.031	0.356	7	4.656	0.438	234.844	0.444	8	5.250	0.500	281.418	0.534	9	5.844	0.563	327.438	0.623	10	6.438	0.625	371.590	0.708	11	7.031	0.688	412.557	0.786	12	7.625	0.750	449.025	0.857	13	8.219	0.813	479.678	0.916	14	8.813	0.875	503.202	0.961	15	9.406	0.938	518.280	0.990	max	10.000	1.000	523.599	1.000
Correction Points Example	Level (m)	Input	Volume (m <sup>3</sup> )	Output																																																																																							
min	0.500	0.000	3.796	0.000																																																																																							
1	1.094	0.063	17.421	0.026																																																																																							
2	1.688	0.125	39.699	0.069																																																																																							
3	2.281	0.188	69.314	0.126																																																																																							
4	2.875	0.250	104.951	0.195																																																																																							
5	3.469	0.313	145.295	0.272																																																																																							
6	4.063	0.375	189.031	0.356																																																																																							
7	4.656	0.438	234.844	0.444																																																																																							
8	5.250	0.500	281.418	0.534																																																																																							
9	5.844	0.563	327.438	0.623																																																																																							
10	6.438	0.625	371.590	0.708																																																																																							
11	7.031	0.688	412.557	0.786																																																																																							
12	7.625	0.750	449.025	0.857																																																																																							
13	8.219	0.813	479.678	0.916																																																																																							
14	8.813	0.875	503.202	0.961																																																																																							
15	9.406	0.938	518.280	0.990																																																																																							
max	10.000	1.000	523.599	1.000																																																																																							
OUT-01 TABLE to OUT-n	<p><i>This parameter is available for viewing and editing only when the correction type is set to Non-linear.</i></p> <p>Enter the normalised output value for the correction point.</p>																																																																																										
REMOTE KEY	<p>You can assign the remote key input to duplicate any one of the key switches on the front panel.</p> <p>Press ▲ or ▼ to select NO-1 through NO-5 as the key on the front panel (from left to right) that is set as the remote key input. Select NONE to disable the remote key function.</p>																																																																																										

## Outputs

[SET] ↓	▶ → UNITS PARAMS INPUTS <b>OUTPUTS</b> ALARMS COMMS TM/LOG SETUP TEST END
LOGIC    IOUT1	<p>You can assign any of the main menu variables to the logic control output. It can be used to control the amount of product in a tank by activating a pump or valve for refilling the tank.</p> <p>Press ▲ or ▼ to select the variable that is required as an output.</p>
PT-ON    IOUT1 PT-OFF   IOUT1	<p>The digital output control ON point determines the value at which the output is activated. The control OFF point determines the value at which the output is deactivated.</p> <p>The control ON point should be lower than the control OFF point.</p> <p>For example, if the “% FULL” variable is assigned to the control output and it is desired to keep the product in the tank between 30 and 70% full, the PT-ON should be set to 30.0 and the PT-OFF should be set to 70.0.</p> <p>If the product level falls below 30% FULL the output will activate and will remain ON until the product reaches 70% FULL. At which point the output will deactivate and remain OFF until the product once again falls below 30%.</p>
4-20    A-OUT	<p>You can assign any of the “rate” main menu variables to the 4-20mA output.</p> <p>Press ▲ or ▼ to select the variable that is required as an output.</p>
PT-MIN   A-OUT PT-MAX   A-OUT	<p>The output minimum value corresponds to the 4mA point and the output maximum value corresponds to the 20mA point.</p> <p>Setting the output range differently from the input range enables the instrument to amplify the input signal. You can drive a chart recorder that “zooms in” on a specified range of values instead of displaying the full operating range of the transducer.</p> <p>For example, if the minimum point is set to 30% and the maximum point is set to 100%, the 4 to 20mA range would reflect the product level range of 30 to 100%. At level above the maximum and below the minimum points, the output remains at 20mA and 4mA respectively.</p>

## Alarms

The alarm relay(s) can be assigned to rate variables such as level, or set as an equipment failure alarm.

The alarm switches “on” whenever an alarm condition exists. The alarm switches “off” when the alarm condition no longer exists. For further details, refer to [Operation of Alarms](#) on page 22.

### Equipment Failure Alarm

Any alarm relay can be assigned as an equipment failure alarm. This alarm setting can have normally closed (open) contacts that open (close) when the instrument displays any error message as listed in [Error Messages](#) on page 45.

<input type="button" value="SET"/> ↓	<input type="button" value="▶"/> → UNITS PARAMS INPUTS OUTPUTS <b>ALARMS</b> COMMS TM/LOG SETUP TEST END
RELAY ALRM $n$	<p>Select a rate variable to assign to the alarm relay.</p> <p><b>Note:</b> If the alarm type is set to “equipment alarm”, this relay assignment setting is ignored.</p> <p>Press <input type="button" value="▲"/> or <input type="button" value="▼"/> to select the variable that is required as an alarm.</p>
TYPE ALRM $n$	<p>The options available for alarm types are as follows:</p> <ul style="list-style-type: none"> <li>• HI-NO — High Alarm, Normally Open contacts</li> <li>• HI-NC — High Alarm, Normally Closed contacts</li> <li>• LO-NO — Low Alarm, Normally Open contacts</li> <li>• LO-NC — Low Alarm, Normally Closed contacts</li> <li>• BD-NO — Band Alarm, Normally Open contacts</li> <li>• BD-NC — Band Alarm, Normally Closed contacts</li> <li>• AL-NO — Equipment Alarm, Normally Open contacts</li> <li>• AL-NC — Equipment Alarm, Normally Closed contacts</li> </ul> <p>Press <input type="button" value="▲"/> or <input type="button" value="▼"/> to select the type of alarm required.</p>

SET ↓		▶ → UNITS PARAMS INPUTS OUTPUTS <b>ALARMS</b> COMMS TM/LOG SETUP TEST END
POINT	ALRMn	<p><i>The Alarm Setpoint is available for viewing and editing for any alarm type except 'equipment alarms'.</i></p> <p>The Alarm Setpoint is the value (in engineering units of assigned variable) at which the alarm condition occurs and therefore the alarm is on.</p> <p>Each alarm is completely independent, e.g. a High alarm does NOT need to have a higher setpoint than the a Low alarm.</p>
HYST	ALRMn	<p><i>The Alarm Hysteresis is available for viewing and editing for any alarm type except 'equipment alarms'.</i></p> <p>Alarm hysteresis loops occur when the alarm toggles continuously on and off when the process variable is close to the setpoint.</p> <p>For a high alarm, the alarm activates when the value of the variable rises above the alarm setpoint and deactivates when the value falls below the alarm setpoint minus the amount of the hysteresis setting (if any).</p> <p>For a low alarm, the alarm activates when the value of the variable falls below the alarm setpoint and deactivates when the value rises above the alarm setpoint plus the amount of the hysteresis setting (if any).</p> <p>For a band alarm, the alarm activates whenever the value of the variable is outside the setpoint plus or minus the amount of the hysteresis.</p> <p>For example, with a high alarm setpoint of 200, and a hysteresis setting of zero, a value oscillating between 197 and 202 will cause the alarm to toggle on at 200 and toggle off below 200. However, if the hysteresis is set to 5, the value of the variable must fall below 195 to cancel the alarm. The alarm will reactivate only when the value again rises above 200.</p>

## Communications

The instrument has the following communication ports:

- **RS-232 Port** - Three terminals on the rear of the instrument. There is also an optional 9-pin female connector on the rear panel of the instrument.
- **RS-485 Port** - Terminals on the rear panel.
- **Infra-red Port** (optional) - Discontinued - Although program settings may be visible in calibration, the required hardware is no longer available. The Infra-red protocol assignment (PROTOC INFR) should be set to NONE and the remaining INFR settings can be ignored.

<input type="button" value="SET"/> ↓	<input type="button" value="▶"/> → UNITS PARAMS INPUTS OUTPUTS ALARMS <b>COMMS</b> <small>TM/LOG SETUP TEST END</small>
PROTOC    RS232 RS485 INFRA	<p>The Communications Protocols can be assigned to the communication ports as follows (a protocol cannot be assigned to more than one port at a time):</p> <ul style="list-style-type: none"> <li>• <b>RTU</b>        - Modbus RTU        available for all ports</li> <li>• <b>PRN</b>        - Printer Protocol    available for RS232 and RS485</li> <li>• <b>NONE</b>      - If a port is not being used, set the protocol to NONE.</li> </ul> <p>Printer Protocol (PRN) is only available if the option with Real Time Clock is installed.</p> <p>For the selected port, press <input type="button" value="▲"/> or <input type="button" value="▼"/> to select the desired protocol.</p>
BAUD        RS232 RS485 INFRA	<p>The Baud setting is the speed of the communication port in data bits per second.</p> <p>The baud rate of the instrument must match the baud rate of the communication device that the instrument is connected to.</p> <p>Use <input type="button" value="▲"/> or <input type="button" value="▼"/> to select 2400, 4800, 9600 or 19200 baud.</p>
PARITY     RS232 RS485 INFRA	<p>The Parity bit helps to detect data corruption that might occur during transmission.</p> <p>The parity bit setting of the instrument must match the parity bit setting of the communication device that the instrument is connected to.</p> <p>Press <input type="button" value="▲"/> or <input type="button" value="▼"/> to select EVEN, ODD, or NONE.</p>
S-BITS     RS232 RS485 INFRA	<p>The Stop bit indicates the end of a transmission. Stop bits can be 1 or 2 bit periods in length. The stop bit setting of the instrument must match the stop bit setting of the communication device that the instrument is connected to.</p> <p>Press <input type="button" value="▲"/> or <input type="button" value="▼"/> to select 1 or 2 stop bits.</p>
RTU         DATA	<p>The Modbus RTU data format for the 2-register (4-byte) values can be set as either floating point or long integer values.</p> <p>Use <input type="button" value="▲"/> or <input type="button" value="▼"/> to select FLOAT or INTEGER.</p>

<input type="button" value="SET"/> ↓	<input type="button" value="▶"/> → UNITS PARAMS INPUTS OUTPUTS ALARMS <b>COMMS</b> TM/LOG SETUP TEST END
RTU      ADDR	<p>The Modbus RTU protocol address must be in the range of 1 to 247. When multiple instruments (slaves) are connected to one communication device (master), each assigned address must be unique.</p> <p><b>Note:</b> The master device uses the RTU address 0 (zero) for broadcasting to all connected slave units.</p>
FLASH    PORT	<p>The Flash Driver Port assignment defines the communication port for downloading software into the instrument.</p> <p>The default setting of this assignment is the RS-232 port.</p> <p>Press <input type="button" value="▲"/> or <input type="button" value="▼"/> to select RS-232, RS-485, or INFRA.</p>

## Time Settings and Data Logging

### Instrument Clock

**Note:** The real-time clock is part of the advanced option package.

The instrument has a real-time clock for recording logged events. The clock displays the time and the date. The date format can be set to European format (day/month/year) or American format (month/day/year). The time clock uses the 24-hour format.

The clock will continue to operate for up to 5 years (typically) on the internal battery if there is no power connected to the instrument. Therefore, after an interruption to the power supply, the instrument recommences normal operation although there will be no data recorded during the period without a power supply.

**Note:** If there is an interruption to the power supply and the battery has failed, the instrument displays an error message when the power supply is restored. In this case, you should set the current time and date so that the instrument continues to log data at the correct times.

### Data Logging

The instrument can store up to 100 log entries of the main-menu variables. These logs can all be for one time interval, or shared with other timescales. For example, you can specify 40 hourly logs, 30 daily logs, 15 weekly logs, 10 monthly logs and 5 yearly logs.

The log parameters (below) for each timebase also determine the number of records to be included in a report print out if the printing option is used.



SET ↓	▶ → UNITS PARAMS INPUTS OUTPUTS ALARMS COMMS <b>TM/LOG</b> SETUP TEST END
DATE      FORM	<p>Clock Date Format</p> <p>The European date format is: dd/mm/yyyy or (Day-Month).</p> <p>The American date format is: mm/dd/yyyy or (Month-Day).</p> <p>Press ▲ or ▼ to select DAY-M or M-DAY</p>
CLOCK      YEAR	The Clock Year defines the current year for the real-time clock.
CLOCK      M-DAY	The Clock M-DAY setting defines the current month and date for the real-time clock. This parameter is programmed in Month-Day format for both European and American date formats.
CLOCK      H-MIN	The Clock H-MIN setting is the current time in hours and minutes for the real-time clock.
HOUR      LOGS	<p>Set the number of Hourly Logs to be recorded and to appear on the printed log report.</p> <p>The hourly log entry occurs at 00 minutes each hour.</p>
DAY      LOGS	<p>Set the number of Daily Logs to be recorded and to appear on the printed log report.</p> <p>The daily log entry occurs at 00 hours and 00 minutes each day.</p>
WEEK      LOGS	<p>Set the number of Weekly Logs to be recorded and to appear on the printed log report.</p> <p>The weekly log entry occurs at 00 hours and 00 minutes each Monday.</p>
MONTH      LOGS	<p>Set the number of Monthly Logs to be recorded and to appear on the printed log report.</p> <p>The monthly log entry occurs at 00 hours and 00 minutes on the first day of the month.</p>
YEAR      LOGS	<p>Set the number of Yearly Logs to be recorded and to appear on the printed log report.</p> <p>The yearly log entry occurs at 00 hours and 00 minutes on the first day of the year.</p>

SET ↓	▶ → UNITS PARAMS INPUTS OUTPUTS ALARMS COMMS <b>TM/LOG</b> SETUP TEST END
RESET LOGS	<p>Reset the logged data. You may need to reset (clear) the logged data if you change the time/log settings.</p> <p>Press ▲ or ▼ to select YES, then press the SET key. The instrument makes three beeps to confirm the reset command.</p>
REPORT TYPE	<p>The Printer Protocol Report Type determines the nature of the printout from the REPORT PRINT - HOLD.SET prompt in the main menu. The following report types available in this instrument are:</p> <ul style="list-style-type: none"> <li>• REP-01 Hourly Logs Report</li> <li>• REP-02 Daily Logs Report</li> <li>• REP-03 Weekly Logs Report</li> <li>• REP-04 Monthly Logs Report</li> <li>• REP-05 Yearly Logs Report</li> <li>• REP-06 Previous Day's 24 Hour Report (0Hr – 23Hr, minimum 48 hourly logs required)</li> </ul> <p>Press ▲ or ▼ to select Report Type.</p>
PRN TYPE	<p>The Printer Protocol Printer Type allows the nature of the printer being used to be specified. The following printer types available in this instrument are:</p> <ul style="list-style-type: none"> <li>• PRN-01 Generic computer printer</li> <li>• PRN-02 Generic roll printer (prints first line first)</li> <li>• PRN-03 Slip printer TM295</li> </ul> <p>Press ▲ or ▼ to select Printer Type.</p>

## General Setup Parameters

SET ↓	▶ → UNITS PARAMS INPUTS OUTPUTS ALARMS COMMS TM/LOG <b>SETUP</b> TEST END
DEFAULT VAR	<p>Select the main menu variable to display on power up or when the display timeout period has elapsed if it is enabled.</p> <p>Press ▲ or ▼ to select the default variable display.</p>
SUPPLY VOLT	<p>The instrument provides a power-limited supply for external transducers.</p> <p>Press ▲ or ▼ to set the transducer supply voltage between 8 and 24 volts DC as required.</p>

SET ↓	▶ → UNITS PARAMS INPUTS OUTPUTS ALARMS COMMS TM/LOG <b>SETUP</b> TEST END
T-OUT MODE	<p>If the Display Timeout mode is enabled, and there is no user activity for the defined timeout period, the display panel returns to the default display.</p> <p>This function is useful for the following reasons:</p> <ul style="list-style-type: none"> <li>to return the display to a preferred variable after the user has finished reading other information,</li> <li>to cancel the calibration mode and return to the default display if the user does not exit from the calibration mode for any reason.</li> </ul> <p>Press ▲ or ▼ to select the display timeout function as follows:</p> <ul style="list-style-type: none"> <li><b>DISABLE</b> - Timeout is completely disabled.</li> <li><b>EN DISP</b> - Timeout is enabled during Normal mode and Calibration View mode.</li> <li><b>EN EDIT</b> - Timeout is enabled during Calibration Set mode.</li> <li><b>EN ALL</b> - Timeout is enabled for all modes.</li> </ul>
T-OUT SEC	<p>The Display Timeout period defines the delay for the Display Timeout mode if it is enabled.</p> <p>The display timeout period can be from 10 to 99 seconds.</p>
DISPL TAGS	<p>The Display Tags option determines whether the instrument displays the default display tags or the user-defined tags. The display tag setting also defines whether the instrument displays the default error and warning messages, or the user-defined messages.</p> <p><b>Note:</b> The user-defined tags can be entered into the instrument only by the manufacturer or the distributor.</p> <p>Press ▲ or ▼ to select the Display Tags option as follows:</p> <ul style="list-style-type: none"> <li><b>DEFAULT</b> - the instrument displays the default (English) tags</li> <li><b>USER</b> - the instrument displays the user-defined tags.</li> </ul>
BACK-L T-OUT	<p>If the backlight timeout is enabled, and there is no user activity (any keys pressed) for a period of 10 seconds, the display backlight switches off to save power. The backlight switches on when a key is pressed. Select the backlight timeout mode as required.</p> <p>Press ▲ or ▼ to select ENABLE or DISABLE.</p>

## Test Menu

The Test menu enables you to view the inputs and outputs to and from the instrument.

In Calibration Set mode, (by entering the system password) you can control the outputs and the alarms as described in the table below.

[SET] ↓	▶ → UNITS PARAMS INPUTS OUTPUTS ALARMS COMMS TM/LOG SETUP <b>TEST</b> END
AINP mA	The current of the signal input to AINP is displayed in milliamps.
LINP <sub>n</sub> STATE	You can view the state of the logic input. If the input is an open contact or inactive it will display <b>HI</b> . If the input is a closed contact or active it will display <b>LO</b> .
IOU <sub>n</sub> STATE	You can control the state of the outputs. Press the ▲ or ▼ keys to set the output state as follows: <ul style="list-style-type: none"> <li>• <b>PROCESS</b> - the output depends on the current values of the inputs and the calculations that the instrument performs.</li> <li>• <b>ON</b> - the output is activated.</li> <li>• <b>OFF</b> - the output is deactivated.</li> </ul>
A-OUT STATE	You can control the state of the outputs. Press the ▲ or ▼ keys to set the output state as follows: <ul style="list-style-type: none"> <li>• <b>PROCESS</b> - the output depends on the current values of the inputs and the calculations that the instrument performs.</li> <li>• <b>HI</b> - the output is set to 20mA.</li> <li>• <b>LO</b> - the output is set to 4mA.</li> </ul>
ALARM <sub>n</sub> STATE or REL <sub>-n</sub>	You can control the state of the relays (alarms). Press the ▲ or ▼ keys to set the selected relay as follows: <ul style="list-style-type: none"> <li>• <b>PROCESS</b> - the relay operates according to the current values of the inputs and the relay settings as programmed.</li> <li>• <b>OPEN</b> - the relay output contacts are set to “open”.</li> <li>• <b>CLOSED</b> - the relay output contacts are set to “closed”.</li> </ul>
SUPPLY ✓	You can display the actual DC output supply voltage, which may help with troubleshooting.  If the actual supply voltage is lower than the preset value (refer to <b>General Setup Parameters</b> on page 42) it may indicate that the output is overloaded.

## System Messages

The instrument displays messages for defined events and fault conditions.

The manufacturer or distributor can enter user-defined text for the messages. This user-defined text is displayed, instead of the default (English) messages, when the Display Tags option in the Setup menu is set to USER.

## Error Messages

The system displays error messages as described in the following table:

Error Messages	Description
CPU Card Failure	There are failed components on the CPU card and technical support is required.
Power Supply is Low	The input and/or output power supply voltage is too low, ensure that: (a) input power supply voltage is within the specified range (b) output power supply is not overloaded.
New/Failed Battery - Set Time	The real-time clock has lost the correct time because the battery has failed, or there is a new battery. Set the current time and date (in the TM/LOG menu) to clear the error message and to continue data logging at the correct times.  <b>Note:</b> The instrument can continue operating with a failed battery, but the correct time will be lost if there are interruptions to the power supply.
Analog Input Signal Failure	The level sensor (analog input) has failed.  It is not possible to override this error condition. The instrument cannot operate without a level input.

## Warning Messages

The system displays warning messages as described in the following table:

Warning Messages	Description
Value Has Been Set to Default	You have entered an invalid value for a parameter. Therefore, the instrument has set the default value.
Over Total Limit - Maximum Set	You have exceeded the maximum number of logging entries for the combined time bases. The instrument has set the current log setting to the remaining maximum number.
Already Assigned to Other Port	You have tried to assign a particular protocol type to more than one serial communication port. The instrument has set the protocol to NONE.

## Alarm Messages

The instrument displays alarm messages as described in the following table:

<b>Alarm Messages</b>	<b>Description</b>
Alarm 1 is Active	The alarm condition, as defined for relay alarm 1 in the ALARMS section of calibration, is present.
Alarm 2 is Active	The alarm condition, as defined for relay alarm 2 in the ALARMS section of calibration, is present.

# Chapter 6

## Communications

---

### Overview

This chapter describes the communications between the instrument and another communicating device such as a computer or a printer. You should have relevant information about the devices to which the instrument will be connected. Some connection examples are included in this manual, however, the operation and connection of other devices is outside the scope of this manual.

### Hardware Interconnection

The instrument has two communication ports:

- RS-232 port on the rear panel (plus extra DB9 female connector)
- RS-485 port on the rear panel

The appropriate interface and protocols are selected during calibration.

#### RS-232 Port

The RS-232 port provides communication between the instrument and one other device such as a host computer or a printer.

**Note:** A printer must have a serial port to be able to be directly connected to the flow computer. It is not possible to communicate directly with a printer via a parallel port.

Computers use either a DB9 or a DB25 connector, and the connections to each type are shown in Figure 13.

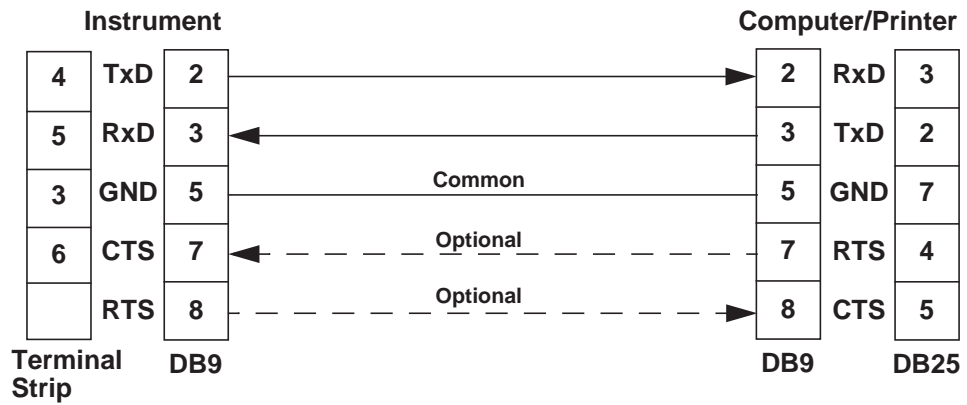

Figure 13 RS-232 Cable Connections to a Computer

**Note:** The instrument requires a cable with straight-through connections. Do not use a null modem cable for RS-232 connection to a computer.

### RS-485 Port

The RS-485 port enables communication with multiple devices. Each device has a unique address so that the “master” device can communicate with specific “slave” devices.

On RS-485 links, an external terminating resistor must be connected at the furthest end of the cable. When multiple instruments are connected, they should be “daisy chained” in a multidrop configuration as shown in Figure 14. Up to 32 units can be connected to the interface at a maximum distance of 1200 metres.

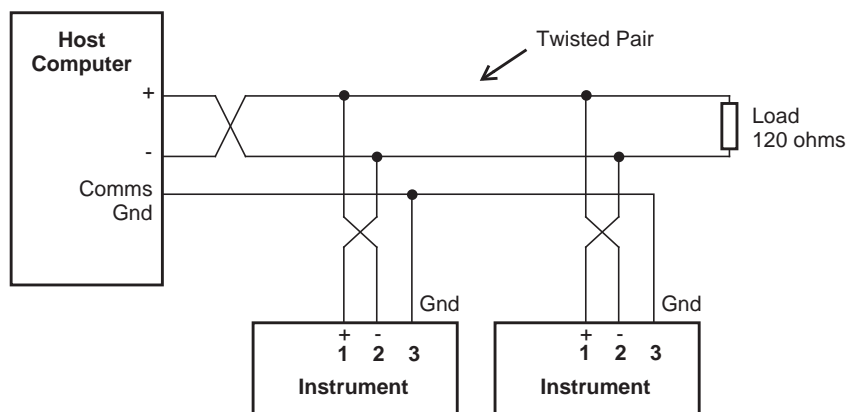

Figure 14 RS-485 Connections



## Protocols

The communications protocols can be assigned to the communication ports on the instrument as follows:

- **RTU** - Modbus RTU available for all ports
- **PRN** - Printer Protocol available for RS232 and RS485
- **NONE** - If a port is not being used, set the protocol to NONE.

**Note:** The Printer Protocol is only available if the option with Real Time Clock is installed. Also a protocol cannot be assigned to more than one port at a time as described in **Communications** on page 38.

- **Modbus RTU** - Modbus RTU is an industry-standard protocol which allows the instrument to be easily connected to computers running supervisory software systems.
- **Printer** - In the Printer protocol there is a selection of printer types. Please refer to the **Printer Protocol** on page 55 for full details.

## Modbus RTU Protocol

Modbus RTU (remote terminal unit) is an industry standard protocol that allows the instrument to be easily interfaced to other communication devices.

The instrument implements the Modbus protocol as detailed in the *Modicon Modbus Protocol Reference Guide* PI-MBUS-300 Rev J (June 1996).

### Message Format

In RTU mode, messages start with a silent interval of at least 3.5 character times. The first field transmitted is the device address. Following the last transmitted character, a similar interval of at least 3.5 character times marks the end of the message. A new message can begin after this interval. The entire message frame must be transmitted as a continuous stream. A typical message frame is shown below:

Address	Function	Data	CRC Check
1 byte	1 byte	n bytes	2 bytes

Except for broadcast messages, when a master device sends a query to a slave device, it expects a normal response. One of four possible events can occur from the master's query:

- If the slave device receives the query without a communication error, and can handle the query normally, it returns a normal response.

- If the slave does not receive the query due to a communication error, no response is returned. The master program has to process a timeout condition for the query.
- If the slave receives the query, but detects a communications error (parity or CRC), no response is returned. The master program has to process a timeout condition for the query.
- If the slave receives the query without a communication error, but cannot handle it (for example, if the request is to read a nonexistent register), the slave will return an exception response informing the master of the nature of the error.

### Instrument Address

The address of the instrument is programmable in the range from 1 to 247. Some addresses are reserved according to PI-MBUS-300 and have a special meaning:

- 0 = Broadcast, no response required from slave devices
- 248 to 255 Reserved

### Function Codes

The instrument accepts the following function codes:

Code	Name	Description
03	Read data register(s)	Obtain the content of one or more 2-byte data registers.
06	Preset data register	Preset one 2-byte data register.
07	Read status register	Obtain the content of 1-byte status register.
16	Preset data register(s)	Preset one or more 2-byte data registers.

## Exception Response

The instrument forms an exception response by adding 80H to the function code and using an exception code as the 1-byte data field in the returned frame. Implemented exception codes are as follows:

Code	Name	Description
01	Illegal function	The function code is not a legal action for the slave.
02	Illegal data address	The data address is not a legal address for the slave.
03	Illegal data value	The data value is not a legal value for the slave.
05	Acknowledge	The slave has accepted the request and is processing it, but a long duration of time will be required to do so.
06	Slave device busy	The slave is engaged in processing a long duration program command. The master should re-transmit the message later when the slave is free.

## List of Data Registers

The following list describes the addresses and meaning of the data registers in the instrument. The data values are expressed in the engineering units that were selected for the variables when the instrument settings were configured. The “Data Type” for the 2-register (4-byte) data values can be set in programming mode as Floating Point or Long Integer as described in **Communications** on page 38.

The registers are grouped in blocks that relate to a particular function of the instrument.

**Note:** Conventional numbering of registers often starts from 1, therefore be aware that “register 1” in this case has “address 0” and so on.

### Current and Logged Process Data

This block of registers is available for the retrieval of current or logged process data with its matching time and date information.

Use the log timebase and log number to retrieve the logged information from the appropriate register. If a particular log number does not exist, or the instrument does not have the optional real-time clock, the time and date stamp and associated variables are set to zero.

Register	Name	Comments	Read Only or Read/Write	Type
1	Product Volume	Process Variables	R	DT*
3	Product Level		R	DT
5	Volume Full Percentage		R	DT
7	Product Mass		R	DT
9	Reserved		R	DT
11	Reserved		R	DT
13	Reserved		R	DT
15	Reserved		R	DT
17	Reserved		R	DT
19	Reserved		R	DT
21	Reserved		R	DT
23	Reserved		R	DT
25	Reserved		R	DT
27	Reserved		R	DT
29	Reserved		R	DT
31	Year	Current Date/Time or Logged Date/Time Stamp (see register 38 Log Number). Only current Date/Time can be edited	R/W	I†
32	Month		R/W	I
33	Date		R/W	I
34	Hour		R/W	I
35	Minute		R/W	I
36	Second		R	I
37	Log Type	00 - hourly or log records 01 - daily 02 - weekly 03 - monthly 04 - yearly 05 - last edit of calibration	R/W	I
38	Log Number	If set to 0, current variables and Date/Time are retrieved	R/W	I
39	Clear Data	01 - clear logs 02 - clear accumulated totals 03 - clear non accumulated totals	W	I
40	Reserved			

\* DT = Data Type of 2-register (4 byte) values can be set as Floating Point or Long Integer values

† I = Integer (2 bytes) (Holding Registers)

**Note:** The Floating Point variable is represented in IEEE-754 Floating Point 4-byte format and requires two 2-byte data registers:

IEEE-754	Modicon Registers
1st byte	low byte (register X)
2nd byte	high byte (register X)

<b>IEEE-754</b>	<b>Modicon Registers</b>
3rd byte	low byte (register X+1)
4th byte	high byte (register X+1)

This means that two data registers must be read or written to obtain, or preset, one data value.

### Instrument Exception Status

This register is available to verify the status of the instrument.

Register	Name	Comments	Read Only or Read/Write	Type
41	Exception Status	00 = no error 01 = analog input 1 failure 02 = analog input 2 failure 03 = analog input 3 failure 04 = analog input 4 failure 05 = invalid calibration parameter 06 = invalid reference parameter 07 = invalid property 08 to 09 reserved 10 = process parameters out of range 11 = input is over limit 12 = flow error detected 20 = system failure 21 = power supply is low 22 = new or failed clock battery 23 to 29 reserved 30 = alarm 1 active 31 = alarm 2 active 32 = alarm 3 active 33 = alarm 4 active	R	I*

\* I = Integer (2 bytes) (Holding Registers)

### Instrument Configuration, Control and I/O

This block of registers is available in some applications to give access to important information in the instrument.

Register	Name	Comments	Read Only or Read/Write	Type
42	Reserved			
43	Reserved			
44	Reserved			
45	Relay State	0 to 15 Binary representation of relay status. 0 = open; 1 = closed.  B0 = relay 1 (LSB) B1 = relay 2	R	I*

Register	Name	Comments	Read Only or Read/Write	Type
46	Relay Control	0 to 15 Binary representation of relay control. 0 = open; 1 = close.  B0 = relay 1 (LSB) B1 = relay 2	R/W	I
47	Relay Control Source	0 to 15 Binary representation of relay control source. 0 = Local (controlled by instrument operation) 1 = RTU (controlled by Modbus register 46).  B0 = relay 1 (LSB) B1 = relay 2	R/W	I
48 to 50	Reserved			
51 to 99	Reserved			
101	Analog Input	The input is configured for 4-20mA. The value will be read in Amperes.	R	DT†

\* I = Integer (2 bytes) (Holding Registers)

† DT = Data Type of 2-register (4 byte) values can be set as Floating Point or Long Integer values

## Printer Protocol

A printer protocol is available in the 500 Series. It provides the ability to print out live data, individual logged data and to do some report-style printing of logged data. The method of printing these and the format of the printouts is described below.

**Note:** Printer output is only available if the Real Time Clock option is fitted.

The selection of Printer Protocol can be made for the Communications Protocol options for the RS232 or RS485 port. A list of log report types and printer types available at the end of the TM-LOG calibration menu.

### Report Types

The list of report types is as follows:

- REP-01      Hourly Logs Report
- REP-02      Daily Logs Report
- REP-03      Weekly Logs Report
- REP-04      Monthly Logs Report
- REP-05      Yearly Logs Report
- REP-06      Previous Day Hourly Logs (0Hr – 23Hr, minimum 48 hourly logs required)

The number of logs printed in each report are determined by the values programmed for each timebase in the TM-LOG menu.

### Printer Types

The list of available printers is as follows:

- PRN-01      Generic computer printer
- PRN-02      Generic roll printer (printing first line first)
- PRN-03      Slip Printer TM295

### Customizing a Printout

A customized printout can be provided which can have up to 4 header lines and 3 footer lines. It is also possible to include or exclude each main menu items on the printout. If any customizing of the printout is required discuss this with the distributor.

## Types of Printouts

### Live Data

The CLEAR key, when in main menu, is shared as the PRINT key if the printer protocol has been selected. A printout will be initiated whenever this key is pressed. If printing is not required, do not select printer protocol.

The format of this printout will be:

*Custom Header Line 1*  
*Custom Header Line 2*  
*Custom Header Line 3*  
*Custom Header Line 4*

*Current Docket No.*

*Instrument Serial No. & Tag*

*Current Date & Time & Status*

*Variable                    unit    value*

*Variable                    unit    value*

*etc.*

*Custom Footer Line 1*

*Custom Footer Line 2*

*Custom Footer Line 3*

----- <separation line>

(Note that blank header and footer lines are not printed).

### Docket Number

The docket number that appears on the live data printout indicates the print number. This number is cleared when the accumulated totals are reset.

### Instrument Serial Number and Unit Tag

The instrument serial number and unit tag is the same as the information shown in the Model Info menu. For more details refer to [Model Information](#) on page 21.

### Individual Log Data

When in the Log Menu and while holding the DISPLAY key to view the data of the log of interest the RESET key can be pressed to initiate a printout of that log entry. The printout will have the time and date stamp corresponding to when the log was taken. After the print has been initiated there will be the opportunity to scroll to view another log entry and print again.





*Custom Footer Lines*

----- <separation line>

Reports such as “All Hourly Logs” will print in the historical order, and for those logs that have no data (e.g. unit was powered off at the time) the print will show “Data not available”. i.e.

*Log No. Date & Time & Status*

*Variable                    unit    value*

*Variable                    unit    value*

*etc.*

----- <separation line>

*Log No.    Data Not Available*

----- <separation line>

*Log No. Date & Time & Status*

*Variable                    unit    value*

*Variable                    unit    value*

*etc.*

If the unit is programmed for 0 logs for a particular time base then the report for that time base will only consist of the header and ID information and a “Data Not Available” message. Likewise for the 0Hr to 23Hr report to print the complete report there must be a minimum of 48 hourly logs programmed otherwise “Data Not Available” will be printed for the missing logs.

*Custom Header Lines*

*Title of Report*

*Current Date & Time*

*Instrument Serial No. & Tag*

*Data Not Available*

*Custom Footer Lines*

----- <separation line>

## Printer Data Control

Some printers have limited data buffers and are therefore unable to collect all the print data being transmitted. The 500 Series has the capability of software handshaking. The Xon/Xoff characters can be used by any of the printer types to control the flow of data to ensure that data is not lost.

Some printers will also transmit an Xoff character in response to other events such as printer being off-line, print head not engaged or power being removed. The specific behaviour of the printer being used should be noted.

## **Error Messages**

There are two printer error messages that can be displayed.

### **PAPER OUT**

This message is related to the Printer Type PRN-03 TM295 Slip printer. It is standard procedure with this printer to check for paper status before printing. If a print is attempted but there is no paper the PAPER OUT message will be scrolled. The instrument will continue to poll the printer for paper and if paper is detected before a communications timeout expires the print will commence.

### **COMMS TIMEOUT**

This message is relevant for all printer types and will be activated for the following conditions.

1. If the flow of data is stopped due to software or hardware handshaking and is not allowed to resume before the communications timeout.
2. If Printer Type is PRN-03 Slip printer and a paper status is requested but no response is received within the timeout period.
3. Paper Out has been detected for Printer Type PRN-03 but no paper is inserted within the timeout period.

When a communications timeout error has been activated the message COMMS TIMEOUT will be scrolled once, the request to print will be cleared and the instrument will return to its normal mode.



# Appendix A

## Model Numbers

### Product Codes

Model	Supplementary Code		Description
505	- LM01		
Enclosure	1		Panel mount enclosure
	2		Field mount enclosure (NEMA 4X / IP66)
	3/5		Explosion proof Ex d (IECEX/ATEX), metric glands (5 specifies heater)
	4/6		Explosion proof Ex d (CSA), NPT glands (6 specifies heater)
Output Options	0		<b>Basic</b> - RS232 and RS485 serial ports, 2 relays, 2 pulse outputs, rear key input
	1		<b>Advanced</b> - also includes 4-20mA o/p and Real-time clock for printer output and logging (100 logs)
Extra Options	2		9-way DB connector for RS232 serial port
Power Supply	A		Inputs for 12-28VDC and 110/120 VAC, 50-60Hz
	E		Inputs for 12-28VDC and 220/240 VAC, 50-60Hz
	D		Input for 12-28VDC power only
Display Panel Options	S		Standard option (now with backlight & LCD backup) <i>(original Full option: F, with Infra-Red comms, no longer available)</i>
PCB Protection	C		<b>Conformal coating</b> - required for maximum environmental operating range. Recommended to avoid damage from moisture and corrosion.
	N		<b>None</b> - suitable for IEC standard 654-1 Climatic Conditions up to Class B2 (Heated and/or cooled enclosed locations)
Application Pack Number	LM01		Defines the application software to be loaded into the instrument
For example: Model No. 505.112ESC Displayed on the 500 Series as: Note: The first character represents the CPU installed (factory use only). The remaining 6 characters only represent hardware that affects the operation.			<p style="text-align: center;">1-1--5- 505 MODEL</p>

**Note:** Example full product part number is 505.112ESC-LM01 (This is the number used for placing orders).

## Custom Version Codes

	Code		Description
<b>Origin Code</b> <b>Identifies Distributor</b>	00		Factory Default Application
	01		Contrec Systems Pty. Ltd. Melbourne Australia
	02		Contrec Limited. West Yorkshire UK
	03		
	04		Contrec - USA, LLC. Pelham AL 35124 USA
	05		Flowquip Ltd. Halifax UK
	06		
	etc.		
<b>User Language</b>	0		English (Default)
	1		German
	2		Dutch
	3		French
	4		Spanish
	5		
	etc.		
<b>Distributor's Code</b>	000		Distributor's own choice. Possibly a code that identifies the customer and the application.
	...		
	999		
For example: 02 3 157 Displayed on the 500 Series as:			<b>023 157</b> CUSTOM VERS

## Application Information Code

The Application Information code is an aid for users and service personnel to determine the type of inputs that are used in a particular application. The Application Information code is displayed on the instrument as shown below.

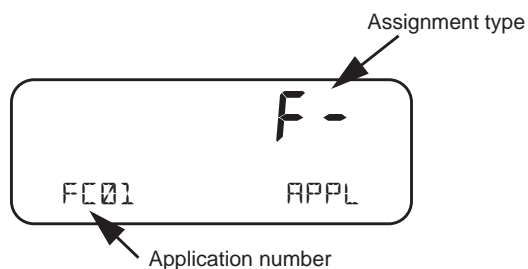

---

The Application number identifies the application as in the following examples:

- BC01 - single channel batch controller for frequency flow input.
- FC01 - single channel flow computer for frequency flow input

The Input Assignment type indicates the physical input that is assigned to each input on the instrument. The code is made up from two characters as follows:

<b>FINP</b>	<b>AINP</b>
<b>X</b>	<b>X</b>

The codes are as follows:

- - - not used in this application
- *A* - indicates an analog flow input such as for volume or mass
- *F* - indicates a frequency flow input such as for volume or mass
- *L* - indicates a level input
- *d* - indicates a density input
- *t* - indicates a temperature input.

For example, *FL* is an instrument with FINP (frequency input) assigned to a flow input, AINP (analog input) assigned to a level input.

# Appendix B

## Units of Measurement

### Available Units of Measurement

The following is a list of the available units of measurement used across the range of 500 Series applications.

Units Type	Available units of measurement
Volume	m <sup>3</sup> , Km <sup>3</sup> , Ltr, mL, Gal, KGal, MGal, ft <sup>3</sup> , kft <sup>3</sup> , Mft <sup>3</sup> , bbl
Volume Flowrate	m <sup>3</sup> /s, m <sup>3</sup> /min, m <sup>3</sup> /h, m <sup>3</sup> /D, L/s, L/min, L/h, L/day, mL/s, mL/min, mL/hr, Gal/s, Gal/min, Gal/h, KGal/D, MGal/D, ft <sup>3</sup> /s, ft <sup>3</sup> /min, ft <sup>3</sup> /h, Mft <sup>3</sup> /D, bbl/s, bbl/min, bbl/h, bbl/D
Volume K-Factor	P/m <sup>3</sup> , P/Ltr, P/mL, P/Gal, P/ft <sup>3</sup> , P/bbl
Mass	kg, g, Ton, lb, Klb
Mass Flowrate	kg/s, kg/min, kg/h, g/s, g/min, g/h, Ton/min, Ton/h, Ton/D, lb/s, lb/min, lb/h, Klb/min, Klb/h, Klb/D
Mass K-Factor	P/kg, P/g, P/Ton, P/lb, P/Klb
Energy	kJ, MJ, GJ, kWh, MWh, kBTU, Ton.h, therm, cal, kcal, Mcal
Power	kJ/h, MJ/h, GJ/h, kW, MW, kBT/M, kBT/h, Ton, therm/min, therm/h, kcal/h, Mcal/h
Energy K-Factor	P/kJ, P/kWh, P/kBTU, P/Ton.h, P/therm, P/kcal
Temperature	Deg K, Deg C, Deg F, Deg R
Pressure	Pa, kg/m <sup>2</sup> , kg/cm <sup>2</sup> , kPa, MPa, mbar, bar, psi, Atm, inH <sub>2</sub> O, mmH <sub>2</sub> O
Density	kg/m <sup>3</sup> , kg/Ltr, lb/ft <sup>3</sup> , SG60F
Specific Volume	m <sup>3</sup> /kg, L/kg, ft <sup>3</sup> /lb
Specific Enthalpy	kJ/kg, BT/lb, cal/g, cal/kg, kcal/kg, Mcal/kg
Reynolds Number	E+0, E+3, E+6 (scaling for unitless variable)
Length (Level)	m, mm, cm, INCH, FOOT
Velocity	m/s, m/M, m/h, ft/s, ft/M, ft/h
Length K-Factor	P/m, P/cm, P/INCH, P/FOOT
Area	m <sup>2</sup> , ft <sup>2</sup>
Ratio	%
General Input	Pressure, Temperature, Density, Length (Level), Factor



# Index

---

## Numerics

4-20mA

- input 11
- output 12

## A

alarm

- connection 13
- equipment failure 37
- hysteresis 38
- relays 36
- setpoint 38

alarms

- menu 21
- messages 46
- setpoints 22

ALARMS key 18

alarms menu 37

application code 62

approvals 4

- FCC Declaration 5

## B

back panel 10

battery

- failed 45
- life 40
- new 45

baud rate 39

## C

calibration

- menu 28
- set mode 26
- view mode 25

CLEAR key 18

clock

- battery 40
- date format 41
- real-time 40

codes

- application information 62
- customer version 62
- exception 53
- product number 61

communication

- connections 14
- protocols 49

communications 3, 47

- menu 38

connections

- alarm 13
- communication 47
- communications 14
- electrical 10
- input 11
- output 12

control modes 22

customer version codes 62

customizing a printout 55

## D

daily logging 41

data log

- viewing 19

data logging

- daily 41
- hourly 41
- monthly 41
- weekly 41
- yearly 41

date format 41

declaration FCC 5

default variable 17

display

- specifications 7
- timeout mode 43
- timeout time 43

DISPLAY key 18, 21

display-only parameter 25

---

## E

earthing 15  
electrical connections 10  
equipment failure alarm 37  
error messages 45  
exception codes 53

## F

features 1  
flash driver port assignment 40  
format, date 41  
front panel  
    keys 17  
    LEDs 17

## H

hardware connections 47  
hourly logging 41  
hysteresis, alarm 38

## I

infra-red port 38  
input  
    4-20mA 11  
    connections 11  
inputs menu 31  
installation 9  
instrument  
    settings 30  
interconnections, communication 47  
interference suppression 14

## K

key  
    ALARMS 18  
    CLEAR 18  
    DISPLAY 18, 21  
    LEVEL 17  
    RESET 18  
    TOTAL 18  
keys, front panel 17

## L

LEDs, status 17  
LEVEL key 17  
logged data 19  
    viewing 19

## logging

daily 41  
hourly 41  
monthly 41  
weekly 41  
yearly 41

## M

main menu items 18

### menu

alarms 37  
calibration 28  
comms 38  
inputs 31  
outputs 36  
params 30  
setup 42  
test 43  
tm/log 40  
units 30

### messages

alarms 46  
error 45  
system 44  
warning 45

Modbus data format 39

Modbus RTU protocol 49

### mode

display timeout 43  
normal operation 17  
process control 22  
set calibration 26  
view calibration 25

model numbers 61

monthly logging 41

mounting 9

## N

normal mode 17

### number

model 61  
serial 21

## O

operation, control modes 22

operation, normal mode 17

### output

connections 12  
    4-20mA 12

---

pulse 12  
outputs menu 36

## P

panel

LEDs 17  
mounting 9  
rear 10

parameter

display-only 25  
not visible 25  
password-protected 25  
programmable 25

parameters menu 30

parity bits 39

password-protected parameter 25

port

assignment, flash driver 40  
flash driver assignment 40  
infra-red 38  
RS-232 14, 38, 47  
RS-485 15, 38, 48

power supply interruption 40

printer

data control 58  
error messages 59  
protocol 55  
report types 55

printer types 55

printouts

individual logs 56  
live data 56  
log report 57  
types 56

product number codes 61

programmable parameters 25

protocol

communication 49  
Modbus RTU 49  
printer 55

pulse output 12

## R

real-time clock 40

rear panel 10

relay outputs 3

relays, alarm 36

remote key input 35

RESET key 18

RS-232 port 14, 38, 47

RS-485 port 15, 38, 48

RTU protocol 49

## S

serial number 21

setpoint, alarm 38

setpoints

alarms 22

settings

instrument 30

setup menu 42

shielding 15

snubber 14

specifications 7

standards 4

status LEDs 17

stop bits 39

suppression, interference 14

system

errors 45

messages 44

warnings 45

## T

terminal designations 10

test menu 43

timeout

mode 43

time 43

tm/log menu 40

TOTAL key 18

## U

unit tag 21

units

menu 30

## V

variable, default 17

version, customer 62

view data logs 19

## W

warnings 45

weekly logging 41

## Y

yearly logging 41